

**DEVELOPMENT OF A BUND STRENGTHENING IMPLEMENT FOR  
PADDY WETLANDS BASED ON SOIL - MACHINE PARAMETERS**

by

**SUMA NAIR  
(2014-28-102)**

**THESIS**

**Submitted in partial fulfilment of the  
requirements for the degree of  
DOCTOR OF PHILOSOPHY**

**IN**

**AGRICULTURAL ENGINEERING  
(Farm Power Machinery)**

**Faculty of Agricultural Engineering & Technology  
Kerala Agricultural University**



**DEPARTMENT OF FARM MACHINERY AND POWER ENGINEERING  
KELAPPAJI COLLEGE OF AGRICULTURAL ENGINEERING AND  
TECHNOLOGY**

**TAVANUR - 679573, MALAPPURAM  
KERALA, INDIA**

**2018**

## DECLARATION

I hereby declare that this thesis entitled “**Development of a bund strengthening implement for paddy wetlands based on soil - machine parameters**” is a *bonafide* record of research work done by me during the course of research and the thesis has not previously formed the basis for the award of any degree, diploma, associateship, fellowship or other similar title of any other University or Society.

**Tavanur:**

**Date :** 15-12-2018

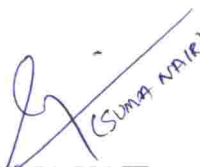
  
**SUMA NAIR**  
**(2014-28-102)**

## CERTIFICATE

Certified that this thesis entitled “**Development of a bund strengthening implement for paddy wetlands based on soil - machine parameters**” is a *bonafide* record of research work done independently by Smt. Suma Nair under my guidance and supervision and that it has not previously formed the basis for the award of any degree, fellowship or associateship to her.



Tavanur

Date: 15-12-2018

**Dr. V. R. Ramachandran**

(Major Advisor, Advisory Committee)

Professor (FPME) & DPP i/c,

Kerala Agricultural University

Vellanikkara, Thrissur, Kerala

## CERTIFICATE

We, the undersigned members of the Advisory Committee of **Smt. Suma Nair (2014-28-102)** a candidate for the degree of Doctorate of Philosophy in Agricultural Engineering majoring in Farm Power Machinery agree that the thesis entitled "**Development of a bund strengthening implement for paddy wetlands based on soil-machine parameters**" may be submitted by **Smt. Suma Nair (2014-28-102)** in partial fulfillment of the requirement for the degree.



**Dr. V.R. Ramachandran**  
(Chairman, Advisory Committee)  
Professor (FPME) & DPP i/c,  
Kerala Agricultural University  
Vellanikkara, Thrissur, Kerala



**Dr. Jayan P.R.**  
(Member, Advisory Committee)  
Professor (FPME)  
KCAET, Tavanur  
Malappuram, Kerala



**Dr. Joby Bastian**  
(Member, Advisory Committee)  
Professor (FPME)  
Regional Agricultural Research Station  
Kumarakom, Kerala



**Dr. Sureshkumar P.K.**  
(Member, Advisory Committee)  
Professor (FPME)  
Dept. of Agricultural Engineering  
College of Horticulture, Vellanikkara



**Dr. Habeeburrahman P.**  
(Member, Advisory Committee)  
Professor and Head  
KVK, Malappuram



15/12/16

**EXTERNAL EXAMINER**  
(**Dr. B. SHRIDHAR**)



## ACKNOWLEDGEMENT

*This work would not have been possible, but for the generous help of a lot of people.*

*At the outset, I express my earnest and heartfelt gratitude and indebtedness to my teacher and Major Advisor **Dr. V.R. Ramachandran**, Professor (FPME) &DPP i/c, KAU, for his invaluable guidance, support and co-operation throughout the period of my study. His active involvement at each and every stage of my study, and his direction, especially during the challenging period of field testing of the developed implement, gave me the confidence to proceed. His kind and patient guidance has permitted me to complete this work.*

*I was fortunate to have **Dr. Jayan P.R.**, Professor, Dept. of FPME, KCAET, **Dr. Joby Bastian**, Professor (FPME), RARS, Kumarakom, **Dr. Sureshkumar P.K.**, Professor (FPME), Dept. of Agricultural Engineering, College of Horticulture, Vellanikkara and **Dr. Habeeburrahman P.V.**, Professor & Head, KVK, Malappuram as Members of my Advisory Committee. Words do not suffice to thank the unending support and help rendered by each of these eminent scientists at all stages of my study.*

*I sincerely thank my teachers, **Dr. M. Sivaswami**, **Dr. Hajilal M.S.**, **Dr. Santhi Mary Mathew**, Formers Deans, and **Dr. Sathian K.K.**, Dean (Ag. Engg.) for their valuable words of advice and supportive encouragement throughout the period of my research work. All the help given by **Dr. Shaji James P.**, Professor & Head, Dept. of FPME, KCAET is gratefully remembered at this juncture. I also thank all the Heads of Departments of KCAET for their support.*

*The enthusiastic and timely help, and expert guidance offered by **Dr. S. Krishnan**, Professor & Head, Dept. of Agricultural Statistics, College of Horticulture, Vellanikkara in sorting out my data and analysing it can never be forgotten.*

*I am beholden to **Dr. K.P. Visalakshi**, Retd. Professor & Head, Dept. of Agricultural Engineering, College of Horticulture for her valuable advice, the unconditional support that she offered at the various stages of my research work, and the constant words of cheer that have helped me a lot to keep up my morale.*

*With a profound sense of gratefulness, I also acknowledge the invaluable and vital help given to me by my colleague in the department, **Er. Shivaji K. P.**, Assistant Professor (FPME), KCAET.*

I remain indebted to **Er. Amrutha K., Er. Rinju Lukose and Er. Anjana S. R.** - my dear students, and more than that, three very enterprising engineers – for their generous support to me.

I take this opportunity to express my deep thankfulness to **Prof. (Dr.) Soman, Prof. (Dr.) Samad, and Er. Amal,** Dept. of Mechanical Engineering, Government Engineering College, Thrissur for their very timely, important and highly appreciated help with a portion of my work.

My heartfelt thanks are also due to **Dr. Rema K.P.,** Professor (LWRCE), KCAET and **Smt. Geetha,** Assistant Executive Engineer, KERI, Thrissur for their suggestions, advice and help for my research. I also thank **Dr. P. Sureshkumar,** Professor & Head, RTL, KAU, Vellanikkara, for permitting to use his laboratory for a portion of my work, and **Dr. Bhindhu P.S. and Dr. Geetha,** RTL, Vellanikkara for helping me with it.

This work could not have been completed without the generous contributions of **Mr. Sreekesh P.S, Mr. Biyoj A.K., Mr. Sharath** from CoH, Vellanikkara, **Mr. Muraleedharan, Mr. Aneesh** from IF, Thrissur, and **Mr. Prasoon, Mr. Sathyan, Mr. Harikrishnan, Mr. Mohammedkutty, Mr. Sudheer, Mr. Pradeep, Mr. Manu, Mr. Shajith, Mr. Dijin & Mr. Unni** from KCAET. But for their assistance during the fabrication, field testing and evaluation studies, this work could not have been completed. Gratitude is also placed on record to **Er. Greeshma K., and Smt. Sharmila Satheesh** of the Dept. of Agrl. Engg., CoH, Vellanikkara for their help during the lab work at CoH, and **Mr. Harikrishnan** for his help with my drawings. The camaraderie of all at the Dept. of Agrl. Engg., CoH is gratefully appreciated, as this department was almost my second home during my study period. I also sincerely thank **Er. Younus, Er. Ragesh, and Er. Sreerag** for their ready help with my queries. I remain grateful that each and every person of the Workshops and Labs in the Dept. of FPME, offered unconditional help whenever, I asked for it.

I cannot find appropriate words to thank the farmers and the officials of the padashekharams of Pullazhi kolepadavu and Kolothumpadam kolepadavu for permitting access to their fields to carry out the field evaluation of my implement; despite the inconveniences caused to them, due to my work. I express my deep gratitude for the complete support of **Sri. Abdul Latheef,** Kolothumpadam, **Dr. Ramachandran,** Pullazhi and **Dr. Sathian,** Athalur, who allowed me to proceed with my work in their fields. I also

take this opportunity to show appreciation for the officials of the State Seed Farm, Mannuthy, especially Mr. Vivek, Tractor Driver, officials of Ollukkara Krishi Bhavan, especially Mr. Salim Shah, Agri. Asst, and the farmers of the Nettissery padashekham for letting me conduct preliminary trials in their paddy fields.

Special thanks are due to my friend and colleague **Dr. Anu Varughese**, KCAET, Tavanur for her unending help and constant support rendered to me. Thanks are also due to my friend **Dr. Renu**, University of Western Australia, for her invaluable help in collecting my references. The encouragement of my friends, colleagues and former batchmates – Er. Gilsha Bai E.B. and Dr. Sudheer K.P. – are also thankfully acknowledged. I also thank my department batchmates – Madhukumara, Dayanand, Dipak, Ayisha, Aswathi, Salsan – and all my classmates including Dr. Ranasalva, Jinu, Dr. Sankalpa, Saranya and Sagarika, for making the period of my study enjoyable.

I express my thanks to all **faculty members, technical, non-teaching and library staff of KCAET**, for their ever willing help and co-operation. Words do not suffice to thank **all the staff and services of the Central Library, KAU, Vellanikkara**.

I also place on record my heartfelt appreciation of my colleagues at KVK, Thrissur, for their support to my work.

I express my sincere gratitude to the **Kerala Agricultural University** for giving me the permission and necessary support to undergo my Ph.D.

Thanks to my family – **Amma, Aravind, Karthika and Karthik** – for their support.

I have been fortunate to get a very encouraging response from all I have contacted in connection with my work, at various stages. It becomes difficult to pen down, as the list seems unending. However, I am forever thankful to each and every one, for their help rendered.

I thank the blessings of my father and the Almighty for making this possible.

Tavanur

Date

Suma

## TABLE OF CONTENTS

Chapter No.	Title	Page No.
	LIST OF TABLES	
	LIST OF FIGURES	
	LIST OF PLATES	
	SYMBOLS AND ABBREVIATIONS	
I	INTRODUCTION	1 – 3
II	REVIEW OF LITERATURE	4 – 33
III	MATERIALS AND METHODS	34 – 87
IV	RESULTS AND DISCUSSION	88 – 202
V	SUMMARY AND CONCLUSION	203 – 211
	REFERENCES	i – xiv
	APPENDICES	
	ABSTRACT	



## LIST OF TABLES

Table No.	Title	Page No.
3.1	Design steps for development of the bund strengthening implement	56-57
3.2	Design considerations and major dimensions of three models of bund strengthening implement	63
4.1	Properties of the field soils at the test locations	93
4.2	Changes in cone index at increasing depths at the test locations	94
4.3	Shear strength measured in the fields at test locations	96
4.4	Organic carbon and organic matter content of soils at test locations	98
4.5	Major dimensions of different models of bund strengthening implements	104
4.6	Summary of changes in bottom width of the bunds at consecutive intervals at Pullazhi <i>kole</i>	110
4.7	Summary of changes in height of the bunds at consecutive intervals at Pullazhi <i>kole</i>	111
4.8	Summary of changes in top width of the bunds at consecutive intervals at Pullazhi <i>kole</i>	112
4.9	Summary of changes in bottom width of the bunds at consecutive intervals at Ponnani <i>kole</i>	114
4.10	Summary of changes in height of the bunds at consecutive intervals at Ponnani <i>kole</i>	115
4.11	Summary of changes in top width of the bunds at consecutive intervals at Ponnani <i>kole</i>	116
4.12	Summary of changes in bottom width of the bunds at consecutive intervals at Tavanur non- <i>kole</i> paddy fields	120

4.13	Summary of changes in height (cm) of the bunds at consecutive intervals at Tavanur (non- <i>kole</i> ) paddy fields	121
4.14	Summary of changes in top width (cm) of the bunds at consecutive intervals at Tavanur (non- <i>kole</i> ) paddy fields	122
4.15	Summary of changes in cone index ( $\text{kg cm}^{-2}$ ) at different depths within bund formed using BF3 at consecutive intervals at Pullazhi <i>kole</i>	130
4.16	Summary of changes in cone index ( $\text{kg cm}^{-2}$ ) at different depths within bund formed using BF2 at consecutive intervals at Pullazhi <i>kole</i>	131
4.17	Summary of changes in cone index ( $\text{kg cm}^{-2}$ ) at different depths within bund formed using BF1 at consecutive intervals at Pullazhi <i>kole</i>	132
4.18	Summary of changes in cone index ( $\text{kg cm}^{-2}$ ) at different depths within bund formed manually at consecutive intervals at Pullazhi <i>kole</i>	133
4.19	Consecutive relative changes in cone index ( $\text{kg cm}^{-2}$ ) of bunds formed at Pullazhi by various methods at 7.5 cm depth	138
4.20	Consecutive relative changes in cone index ( $\text{kg cm}^{-2}$ ) of bunds formed at Pullazhi by various methods at 10.0 cm depth	139
4.21	Consecutive relative changes in cone index ( $\text{kg cm}^{-2}$ ) of bunds formed at Pullazhi by various methods at 12.5 cm depth	139
4.22	Consecutive relative changes in cone index ( $\text{kg cm}^{-2}$ ) of bunds formed at Pullazhi by various methods at 15.0 cm depth	140
4.23	Consecutive relative changes in cone index ( $\text{kg cm}^{-2}$ ) of bunds formed at Pullazhi by various methods at 17.5 cm depth	140
4.24	Consecutive relative changes in cone index ( $\text{kg cm}^{-2}$ ) of bunds formed at Pullazhi by various methods at 20.0 cm depth	141
4.25	Consecutive relative changes in cone index ( $\text{kg cm}^{-2}$ ) of bunds formed at Pullazhi by various methods at 22.5 cm depth	141

4.26	Consecutive relative changes in cone index ( $\text{kg cm}^{-2}$ ) of bunds formed at Pullazhi by various methods at 25.0 cm depth	142
4.27	Consecutive relative changes in cone index ( $\text{kg cm}^{-2}$ ) of bunds formed at Pullazhi by various methods at 27.5 cm depth	142
4.28	Consecutive relative changes in cone index ( $\text{kg cm}^{-2}$ ) of bunds formed at Pullazhi by various methods at 30.0 cm depth	143
4.29	Summary of changes in cone index ( $\text{kg cm}^{-2}$ ) at different depths within bund formed mechanically by BF3 at consecutive intervals at Ponnani <i>kole</i>	144
4.30	Summary of changes in cone index ( $\text{kg cm}^{-2}$ ) at different depths within bund formed mechanically by BF2 at consecutive intervals at Ponnani <i>kole</i>	144
4.31	Summary of changes in cone index ( $\text{kg cm}^{-2}$ ) at different depths within bund formed mechanically by BF4 at consecutive intervals at Ponnani <i>kole</i>	145
4.32	Summary of changes in cone index ( $\text{kg cm}^{-2}$ ) at different depths within bund formed manually at consecutive intervals at Ponnani <i>kole</i>	145
4.33	Consecutive relative changes in cone index ( $\text{kg cm}^{-2}$ ) of bunds formed at Ponnani <i>kole</i> by various methods at 7.5 cm depth	151
4.34	Consecutive relative changes in cone index ( $\text{kg cm}^{-2}$ ) of bunds formed at Ponnani <i>kole</i> by various methods at 10.0 cm depth	151
4.35	Consecutive relative changes in cone index ( $\text{kg cm}^{-2}$ ) of bunds formed at Ponnani <i>kole</i> by various methods at 12.5 cm depth	152
4.36	Consecutive relative changes in cone index ( $\text{kg cm}^{-2}$ ) of bunds formed at Ponnani <i>kole</i> by various methods at 15.0 cm depth	152
4.37	Consecutive relative changes in cone index ( $\text{kg cm}^{-2}$ ) of bunds formed at Ponnani <i>kole</i> by various methods at 17.5 cm depth	153
4.38	Consecutive relative changes in cone index ( $\text{kg cm}^{-2}$ ) of bunds formed at Ponnani <i>kole</i> by various methods at 20.0 cm depth	153

4.39	Consecutive relative changes in cone index ( $\text{kg cm}^{-2}$ ) of bunds formed at Ponnani <i>kole</i> by various methods at 22.5 cm depth	154
4.40	Consecutive relative changes in cone index ( $\text{kg cm}^{-2}$ ) of bunds formed at Ponnani <i>kole</i> by various methods at 25.0 cm depth	154
4.41	Consecutive relative changes in cone index ( $\text{kg cm}^{-2}$ ) of bunds formed at Ponnani <i>kole</i> by various methods at 27.5 cm depth	155
4.42	Consecutive relative changes in cone index ( $\text{kg cm}^{-2}$ ) of bunds formed at Ponnani <i>kole</i> by various methods at 30.0 cm depth	155
4.43	Summary of changes in cone index ( $\text{kg cm}^{-2}$ ) within bund formed using BF3-NH3230 at consecutive intervals at Tavanur paddy fields	157
4.44	Summary of changes in cone index ( $\text{kg cm}^{-2}$ ) within bund formed using BF2-NH3230 at consecutive intervals at Tavanur paddy fields	157
4.45	Summary of changes in cone index ( $\text{kg cm}^{-2}$ ) within bund formed using BF1-NH3230 at consecutive intervals at Tavanur paddy fields	158
4.46	Summary of changes in cone index ( $\text{kg cm}^{-2}$ ) within bund formed using BF4-NH3230 at consecutive intervals at Tavanur paddy fields	158
4.47	Summary of changes in cone index ( $\text{kg cm}^{-2}$ ) at different depths within bund formed manually at consecutive intervals at Tavanur paddy fields	159
4.48	Summary of changes in cone index ( $\text{kg cm}^{-2}$ ) within bund formed using BF2-KTT at consecutive intervals at Tavanur paddy fields	160
4.49	Summary of changes in cone index ( $\text{kg cm}^{-2}$ ) within bund formed using BF1-KTT at consecutive intervals at Tavanur paddy fields	160
4.50	Consecutive relative changes in cone index ( $\text{kg cm}^{-2}$ ) of bunds formed at Tavanur by various methods, using NH 3230 tractor at 7.5 cm depth	167

4.51	Consecutive relative changes in cone index ( $\text{kg cm}^{-2}$ ) of bunds formed at Tavanur by various methods, using NH 3230 tractor, at 10.0 cm depth	168
4.52	Consecutive relative changes in cone index ( $\text{kg cm}^{-2}$ ) of bunds formed at Tavanur by various methods, using NH 3230 tractor, at 12.5 cm depth	169
4.53	Consecutive relative changes in cone index ( $\text{kg cm}^{-2}$ ) of bunds formed at Tavanur by various methods, using NH 3230 tractor, at 15.0 cm depth	169
4.54	Consecutive relative changes in cone index ( $\text{kg cm}^{-2}$ ) of bunds formed at Tavanur by various methods, using NH 3230 tractor, at 17.5 cm depth	170
4.55	Consecutive relative changes in cone index ( $\text{kg cm}^{-2}$ ) of bunds formed at Tavanur by various methods, using NH 3230 tractor, at 20.0 cm depth	170
4.56	Consecutive relative changes in cone index ( $\text{kg cm}^{-2}$ ) of bunds formed at Tavanur by various methods, using NH 3230 tractor, at 22.5 cm depth	171
4.57	Consecutive relative changes in cone index ( $\text{kg cm}^{-2}$ ) of bunds formed at Tavanur by various methods, using NH 3230 tractor, at 25.0 cm depth	171
4.58	Consecutive relative changes in cone index ( $\text{kg cm}^{-2}$ ) of bunds formed at Tavanur by various methods, using NH 3230 tractor, at 27.5 cm depth	172
4.59	Consecutive relative changes in cone index ( $\text{kg cm}^{-2}$ ) of bunds formed at Tavanur by various methods, using NH 3230 tractor, at 30.0 cm depth	172
4.60	Summary of changes in shear strength at a depth of 0.20 m at consecutive time intervals at Pullazhi <i>kole</i>	176
4.61	Summary of changes in shear strength at a depth of 0.40 m at consecutive time intervals at Pullazhi <i>kole</i>	176

4.62	Summary of changes in shear strength at a depth of 0.60 m at consecutive time intervals at Pullazhi <i>kole</i>	176
4.63	Summary of changes in shear strength at a depth of 0.20 m at consecutive intervals at Ponnani <i>kole</i>	178
4.64	Summary of changes in shear strength at a depth of 0.40 cm at consecutive intervals at Ponnani <i>kole</i>	178
4.65	Summary of changes in shear strength at a depth of 0.60 m at consecutive intervals at Ponnani <i>kole</i>	179
4.66	Summary of changes in shear strength at a depth of 0.20 m at consecutive intervals at Tavanur using NH 3230 tractor	182
4.67	Summary of changes in shear strength at a depth of 0.40 m at consecutive intervals at Tavanur using NH 3230 tractor	183
4.68	Summary of changes in shear strength at a depth of 0.60 m at consecutive intervals at Tavanur using NH 3230 tractor	183
4.69	Summary of changes in shear strength at a depth of 0.20 m at consecutive intervals at Tavanur using KTT	184
4.70	Summary of changes in shear strength at a depth of 0.40 m at consecutive intervals at Tavanur using KTT	185
4.71	Summary of changes in shear strength at a depth of 0.60 m at consecutive intervals at Tavanur using KTT	185
4.72	Summary of changes in moisture content of the bunds at consecutive intervals at Pullazhi <i>kole</i>	186
4.73	Summary of changes in moisture content of the bunds at consecutive intervals at Ponnani <i>kole</i>	186
4.74	Summary of changes in moisture content of the bunds at consecutive intervals at Tavanur	186
4.75	Summary of changes in wet bulk density of the bunds at consecutive intervals at Pullazhi <i>kole</i>	189
4.76	Summary of changes in wet bulk density of the bunds at consecutive intervals at Ponnani <i>kole</i>	189

4.77	Summary of changes in wet bulk density of the bunds at consecutive intervals at Tavanur	190
4.78	Speed of operation of different bund strengthening implements at three test locations	193
4.79	Fuel consumed by different bund strengthening implements at three test locations	196
4.80	Capacity of the different bund strengthening implements at three test location	197
4.81	Wheel slip for different bund strengthening implements at three test locations	199
4.82	Cost of formation of 100 meters of bund by different methods	200

---

## LIST OF FIGURES

Fig. No.	Title	Page No.
2.1	Bund former – A- frame type (a) Bullock drawn A- frame (b) Tractor drawn A- frame	9
2.2	Tractor operated bund making machines	9
2.3	Co-ordinate measuring device	13
3.1	Sampling pipette	42
3.2	Determination of soil texture	43
3.3	Tool frame and hitch assembly	64
3.4	Bund strengthening implement model BF1	66
3.5	Bund strengthening implement model BF2	67
3.6	Bund strengthening implement model BF3	68
3.7	DC motor (prime mover)	70
3.8	HC-SR04 sensor	73
3.9	SD card reader	74
3.10	Arduino Uno board with pin configuration	75
3.11	Flow chart of the working concept of the profile measuring instrument	77
4.1	Variation in cone index ( $\text{kg cm}^{-2}$ ) in field soil at the test locations	95
4.2	Changes in shear strength over depth in field soils at the test locations	97
4.3	Front view of the fabricated rectangular object (actually measured)	108



4.4	Front view of the fabricated rectangular object measured by profile measuring instrument	108
4.5	Variation in the different bund dimensions at Pullazhi <i>kole</i>	113
4.6	Variation in the different bund dimensions at Ponnani <i>kole</i>	119
4.7	Variation in the different bund dimensions at Tavanur (Power source : NH 3230)	124
4.8	Variation in the different bund dimensions at Tavanur (Power source : KTT)	125
4.9	Bund profile plotted using profile measuring instrument at Pullazhi <i>kolepadavu</i> , Thrissur <i>kole</i>	126
4.10	Bund profile plotted using profile measuring instrument at Kolothumpadam <i>kolepadavu</i> , Ponnani <i>kole</i>	127
4.11	Bund profile plotted using profile measuring instrument at Tavanur (Power source: NH 3230)	128
4.12	Bund profile plotted using profile measuring instrument at Tavanur (Power source : KTT)	129
4.13	Changes in cone index at increasing depths within different types of bunds at Pullazhi <i>kole</i>	134
4.14	Variation of cone index with depth, on Day 1, in different types of bunds formed	135
4.15	Variation of cone index with depth, on Day 3 in different types of bunds formed	136
4.16	Variation of cone index with depth, on Day 7, in different types of bunds formed	137
4.17	Changes in cone index ( $\text{kg cm}^{-2}$ ) at incremental depths over consecutive time intervals for different types of bunds formed at Ponnani <i>kole</i>	147

4.18	Variation of cone index with depth at consecutive intervals, on Day 1, in different types of bunds at Ponnani <i>kole</i>	148
4.19	Variation of cone index with depth at consecutive intervals, on Day 3, in different types of bunds at Ponnani <i>kole</i>	149
4.20	Variation of cone index with depth at consecutive intervals, on Day 7, in different types of bunds at Ponnani <i>kole</i>	150
4.21 (a)	Changes in cone index ( $\text{kg cm}^{-2}$ ) at incremental depths over consecutive time intervals for manual bunds and bunds formed using BF1 and BF2 at Tavanur (Power source: NH 3230)	162
4.21 (b)	Changes in cone index ( $\text{kg cm}^{-2}$ ) at incremental depths over consecutive time intervals for bunds formed using BF3 and BF4 at Tavanur (Power source: NH 3230)	163
4.22	Changes in cone index ( $\text{kg cm}^{-2}$ ) at incremental depths over consecutive time intervals for manual bunds and bunds formed using BF1 and BF2 at Tavanur (Power source: KTT)	164
4.23	Variation of cone index with depth in different bunds formed with NH 3230 on Day 1 at Tavanur	165
4.24	Variation of cone index with depth in different bunds formed with NH 3230 on Day 3 at Tavanur	166
4.25	Variation of cone index with depth in different bunds formed with NH 3230 on Day 7 at Tavanur	166
4.26	Variation of cone index with depth in different bunds formed with KTT on Day 1 at Tavanur	173
4.27	Variation of cone index with depth in different bunds formed with KTT on Day 3 at Tavanur	174
4.28	Variation of cone index with depth in different bunds formed with KTT on Day 7 at Tavanur	174

4.29	Changes in <i>in situ</i> shear strength of different bunds formed at Pullazhi <i>kole</i> fields at consecutive time intervals and depths	177
4.30	Changes in <i>in situ</i> shear strength of different bunds formed at Ponnani <i>kole</i> fields at consecutive time intervals and depths	180
4.31	Changes in <i>in situ</i> shear strength of different bunds formed at Tavanur fields using NH 3230	181
4.32	Changes in <i>in situ</i> shear strength of different bunds formed at Tavanur fields using KTT	181
4.33	Changes in moisture content of the different bunds at Pullazhi <i>kole</i>	187
4.34	Changes in moisture content of different bunds at Ponnani <i>kole</i>	187
4.35	Changes in moisture content of the different bunds at Tavanur	188
4.36	Variation in wet bulk density of bunds formed at Pullazhi <i>kole</i>	191
4.37	Variation in wet bulk density of bunds formed at Ponnani <i>kole</i>	191
4.38	Variation in wet bulk density of bunds formed at Tavanur	192
4.39	Draft requirement for different bund strengthening implements at Pullazhi <i>kole</i>	194
4.40	Draft requirement for different bund strengthening implements at Ponnani <i>kole</i>	194
4.41	Draft requirement for different bund strengthening implements at Tavanur (Power source: NH 3230 tractor)	195

4.42	Draft requirement for different bund strengthening implements at Tavanur (Power source: KTT)	195
4.43	Variation in cost of formation of 100 m of bund using different methods	199
4.44	Result of the deformation analysis using ANSYS 16.0	201
4.45	Result of the stress analysis using ANSYS 16.0	202

---

## LIST OF PLATES

Plate No.	Title	Page No.
3.1(a)	<i>Kole</i> fields before dewatering	35
3.1(b)	Plate <i>Kole</i> lands after dewatering	35
3.2	Manual strengthening of bunds and manually formed bund	36
3.3	Power tiller operated <i>kaipad</i> bund former	39
3.4	KAMCO Tera Trac operated KAU bed former	39
3.5	Determination of liquid limit	47
3.6	Determination of plastic limit	48
3.7	Determination of shrinkage limit	49
3.8	Set up for measurement of cone index	51
3.9	Initial model of the bund strengthening implement with rear press plate	59
3.10	Bund strengthening implement fitted with rear forming case	60
3.11	Bund formation at Ponnani <i>kole</i> in fields	61
3.12	Profile measurement using pin type profilemeter	69
3.13	Profile measuring component	72
3.14	<i>In situ</i> measurement of the bund profile	79
3.15	Draft measurement in field	85
3.16	Setup for measurement of fuel consumption	85
4.1	Bund formed using power tiller operated <i>kaipad</i> bund former	89
4.2.	Bund formed by KAU bed former using KAMCO TeraTrac mini tractor	90

4.3	Bund formed using the first model	99
4.4	Bund formed with forming case attached to bund strengthening implement	100
4.5	Bund formation at Ponnani <i>kole</i> in fields with low water levels	101
4.6	Sinking of KAMCO TeraTrac tractor at Ponnani <i>kole</i>	102
4.7	Bund strengthening implement – Model BF1	104
4.8	Bund strengthening implement – Model BF2	105
4.9 (a)	Bund strengthening implement – Model BF3 – front view	105
4.9 (b)	Bund strengthening implement – Model BF3 – side view	106

---

## LIST OF SYMBOLS AND ABBREVIATIONS

%	:	per cent
&	:	and
/	:	per
ASAE	:	American Society of Agricultural Engineers
ASTM	:	American Society for Testing and Materials
BF1	:	Bund strengthening implement – Model I
BF2	:	Bund strengthening implement – Model II
BF3	:	Bund strengthening implement – Model III
BF4	:	Combination run of bund strengthening implement BF2 over bunds formed by model BF3
°C	:	degree Celsius
cm	:	centimeter(s)
CO <sub>2</sub>	:	carbon di oxide
D1, D3 and D7	:	First day, third day and seventh day (of observation)
DC	:	direct current
<i>et al.</i>	:	and others
Fig.	:	Figure
FOS	:	factor of safety
g	:	grams
h	:	hour(s)
ha	:	hectare(s)
H <sub>2</sub> O <sub>2</sub>	:	Hydrogen peroxide
JD 5042	:	John Deere 5042 tractor
kPa	:	kilo pascal
kg	:	kilogram(s)

km h <sup>-1</sup>	:	kilometers per hour
kN	:	kilo newton
kW	:	kilowatt
KAMCO	:	Kerala Agro Machinery Corporation Ltd., Athani, Ernakulam
KERI	:	Kerala Engineering Research Institute, Peechi, Thrissur
<i>Kolepadavu</i> or <i>padashekharam</i>	:	A cluster of paddy fields in the <i>kole</i> lands which are considered as a unit and where cultural operations for paddy cultivation are conducted in a synchronized manner
KTT	:	KAMCO Tera Trac mini tractor
K <sub>2</sub> Cr <sub>2</sub> O <sub>7</sub>	:	Potassium di chromate
l h <sup>-1</sup> , L h <sup>-1</sup>	:	litres per hour
L	:	litres
Lab VIEW	:	Laboratory Virtual Instrument Engineering Workbench
m	:	metre(s)
m h <sup>-1</sup>	:	metres per hour
min	:	minute(s)
mm	:	millimetre(s)
MS	:	mild steel
MSL	:	mean sea level
N	:	newton(s)
NaOH	:	sodium hydroxide
NH 3230	:	New Holland 3230 tractor
O <sub>2</sub>	:	Oxygen
PU1, PU2, PU3	:	Sampling sites no. 1, 2 & 3 at Pullazhi <i>kolepadavu</i> , Thrissur <i>kole</i> lands, Thrissur district, Kerala



PO1, PO2, PO3 : Sampling sites no. 1, 2 & 3 at Kolothumpapam  
*kolepadavu*, Ponnani *kole* lands, Malappuram district,  
Kerala

Rs. : Rupees

SD : secure digital

TVR1, TVR2, TVR3 : Sampling sites no. 1, 2 & 3 at Athalur, Tavanur (non-  
*kole*) lands, Malappuram district, Kerala

*viz.* : namely

V : volt(s)

# **Introduction**

## CHAPTER I

### INTRODUCTION

Rice is the staple food for people of many countries in the world. Rice was cultivated in an area of 438.60 lakh hectares in India during 2014-15, with a production of 104.8 lakh MT and a yield of 2390 kg ha<sup>-1</sup> (GoK, 2016). In 2016, India stood second in the world in harvested area under rice (429.65 lakh ha) (Anon., 2017(a)); however we ranked 59<sup>th</sup> in the world with respect to the average yield (3695 kg ha<sup>-1</sup>) (Anon., 2017(b)).

Rice is grown in almost all states of India. For Keralites, rice is an irrevocable essential of their daily diet. Rice was grown in 1.714 lakh ha in Kerala during 2016-17; with a production of 4.371 lakh MT and an estimated yield of 2550 kg ha<sup>-1</sup> (GoK, 2017). Alappuzha, Thrissur, Palakkad and Malappuram districts have vast tracts under rice cultivation. The *kuttanad* coastal basin, Palakkad rice belt and Thrissur *kole* lands form a major share of the area under rice. The *kole*, *pokkali*, *kaipad* and *kuttanad* regions also have the speciality of lying 0.5 to upto 2 m below MSL. These low lying rice cultivating areas of Kerala contribute about 37% to the State's rice production (Chandramohan and Mohanan, 2011).

The *kole* lands of Thrissur are low lying areas, parallel to the coastline in Thrissur district and Ponnani *taluk* of Malappuram district, that remain submerged 0.5 to 1.0 m below MSL, for a greater part of the year. Thrissur district has the higher share of the *kole* lands as compared to Malappuram. These fertile tracts have a great potential for rice production and are important from the point of view of ecological and environmental conservation. While the average rice productivity of the state is around two and a half tonnes per hectare, the yield from the *kole* lands is six to seven tonnes per hectare; these bumper yields being the reason for their name "*kole*", which means "plenteous" in Malayalam. In Thrissur district, there has been a decline in the *kole* area from 9162 ha in 1985 to 6143 ha in 2008 with a decline in production from 38,887 tonnes in 1985 to 26,848 tonnes in 2007;

a boost in productivity has, however, maintained crop production levels (Leema, 2015). The *kole* lands have been identified as one of the Special Agricultural Zones for rice in the state by the Government of Kerala (GoK, 2017). This indicates that more focus will be placed on the cultivation of the crop in this area, requiring an efficient mechanised cultivation protocol.

Most of the labour intensive operations such as, tillage and land preparation, transplanting, harvesting etc., in rice cultivation, have been mechanised in the state, which has brought a revival in the rice cultivation. Mechanisation of field operations is necessary to sustain paddy cultivation and ease the logistic and economic burden of the farmer in these vast tracts of land. However, one of the first field operations, viz., bund forming or strengthening, is still a manual operation, dependent wholly on human labour.

Bunds are essential for proper field water, nutrient and crop management. Rice fields are divided into smaller sections, by small earth embankments called bunds or ridges or dykes, for efficient, precise and timely water and nutrient management. By the end of a season's harvest, which is mostly performed by combine harvesters, the field bunds are practically lost; due to the traffic of machines over them.

The *kole* fields are left fallow after harvest of the season's crop, and they once again fill up with water during the monsoons. Field bunds, from the previous season, remain submerged till dewatering. During this period, they lose their strength and shape and only an outline is left. These remnants of the bund, from the previous season, are to be trimmed and reinforced before each growing season, to ensure proper field conditions for cultivation.

In manual bund formation, the labourers make use of spades to cut soil from both the sides of the existing bunds (from the previous season) and use this soil to plaster the sides and top of the bunds. After plastering both sides of the bund, the top is pressed with the blade of the spade to flatten it, and a bund with trapezoidal cross section is formed. However the cross section of the bund is not

uniform throughout its length. The operation is performed by male labourers, who can form an average of about 375 to 450 metres of bund per day. The prevailing wage rate for such labourers is Rs. 800/- to Rs. 850/- per day of six hours.

Fragmentation of rice fields lead to very large length of bunds being worked upon, each growing season. As scarcity of manual labour in paddy fields is increasing, proper and timely bund strengthening is becoming difficult.

Tractor drawn ridge plastering machines are available for bund formation. These machines can form about 1000 m of bund per hour, but require a higher power source and are very heavy and costly. Moreover, these machines entail a very narrow range of moisture contents for proper functioning, which is not obtainable in *kole*, as water level in the fields vary and are a minimum of 10 to 15 cm above ground level at the time of tillage and bund formation. Many areas in the *kole* permit the use of only power tiller as the power source, due to the problem of sinkage. Models of bund clearing device as an attachment to a two wheel tractor and bund plastering mechanism as a direct attachment to a tractor have also been reported; however no successful devices are observed.

Paddy cultivation practices, especially in the *kole* lands, are stringently time bound, and move forward through the different stages in a systematic, rhythmic pattern, over the entire *padashekharams*; each having an area of approximately 200 ha and more. The scarcity of skilled labour for bund making during the peak period causes great difficulty to the farmers and this points to the need of development of a simple, low cost implement to mechanise the operation of bund forming. Hence, this study for development of a low cost bund strengthening implement was taken up with the following objectives:

1. To study soil-machine parameters relevant to the development of a bund strengthening implement
2. To develop a mechanism for mechanical bund strengthening for paddy wetlands
3. Field testing and performance evaluation of the developed mechanism

# *Review of Literature*

## CHAPTER II

### REVIEW OF LITERATURE

Bund formation is one of the primary operations in paddy wetlands and is presently being performed manually by skilled male labourers. The process is tedious, requires skill and there is a severe dearth of labour for bund formation during the peak period. As cultivation in *kole* lands is strictly time bound, the need for a mechanized alternative is being urgently felt by the rice farmers. Towards this end, a review of the process of bund formation in rice cultivation, the available machinery, and the related soil and machine parameters involved, is attempted in this chapter.

#### 2.1 WETLANDS AND RICE CULTIVATION

Wetlands, as defined under the Ramsar International Convention of 1971, are “areas of marsh, fen, peatland or water, whether natural or artificial, permanent or temporary, with water that is static or flowing, fresh, brackish or salt including areas of marine water, the depth of which at low tide does not exceed six meters” (Barbier *et al.*, 1997).

Cowardin *et al.* (1979) define wetlands as "the lands transitional between terrestrial and aquatic systems where the water table is usually at or near the surface, or the land is covered by shallow water". They delineated a wetland using three attributes: (i) the area must be permanently or periodically inundated or water must be present some point of time during the growing season, (ii) the substrate is non-soil and made of predominantly hydric soil that are undrained and (iii) the area must support hydrophytic vegetation.

Wetlands, which are usually located as a niche in between the dry terrestrial areas and permanent deep water bodies such as rivers, lakes or oceans, are very productive ecosystems and the carriers of organic and inorganic nutrients. They also help to reduce the effects of floods and recouping of groundwater (Srinivasan, 2010).

Rice, the staple food crop of Kerala, is grown in 7.46 per cent of the total cropped area. Drastic decrease is being observed in the area under rice cultivation since the 1980s. The area under rice has come down from 8.82 lakh hectares in 1974-75 to 1.96 lakh hectares in 2015-16, showing a 77 per cent decrease. A corresponding decrease in production is also seen from 13.76 lakh MT in 1972-73 to 5.49 lakh MT in 2015-16 (GoK, 2016).

### 2.1.1 The *Kole* Lands

The *kole* lands are located in central Kerala and are a part of the Vembanad – *kole* wetland ecosystem. They have been notified as a Ramsar site since 2002. These have been reclaimed from the *kayal* (extensive deep water lakes) by erecting temporary earthen bunds. These lands primarily extend in the Thrissur and Malappuram districts of Kerala and lie 0.5 m to 1.0 m below MSL. The *kole* lands, lying between the Bharathapuzha in the north and the Chalakkudy river in the south, are a result of the rich alluvial deposits from the collected flood waters and are drained by the Kechery and Karuvannur rivers into the Arabian Sea. The Mukundapuram, Thrissur and Chavakkad *taluks* constitute the Thrissur *kole* (10,187 ha) while Ponnani *kole* (3,445 ha) is located in Thalappilly and parts of the Chavakkad *taluks* in Thrissur district and Ponnani *taluk* of the Malappuram district. These vast homogeneous, contiguous tracts of low lying land are inundated with water from the start of the monsoons for around six months in a year, with the area completely submerged under water. A network of canals and channels for irrigation and drainage lace the vast *kole* lands, dividing them into *padavus* (blocks of land) for ease of cultivation (Johnkutty and Venugopal, 1993; Sivaperuman and Jayson, 2000; Leema, 2015).

*Kole* lands form one of the major rice granaries of Kerala. One crop of rice is cultivated usually from December to May, in the *puncha* season. The *kuttanad*, *kole*, *pokkali* and *kaipad* are the low lying rice cultivating areas of Kerala, contributing about 37% to the State's rice production (Chandramohan and Mohanan, 2011).



The organic carbon content varied from low (0.53%) to high (1.89%) in six areas assessed (Johnkutty and Venugopal, 1993) while Leema (2015) quotes values of 1.26 per cent of organic carbon in *kole* soils as compared to 0.83 per cent in other paddy fields of Thrissur.

## 2.2 BUND MAKING

Pathirana *et al.* (2010) opined that the bund preparation was one of the difficult tasks involved in paddy cultivation. This task is performed manually at the beginning of the cropping season in two stages. The weeds and grasses on the existing bunds were cleared off first, at the time of initial ploughing. Then, after second ploughing, the bund was plastered with a layer of mud, to form strong bunds that limit water and fertilizer loss. They also reported that approximately 30 minutes were required, by an average farmer, to clear, and 45 minutes to plaster one side of an 18 m long bund. The operation was termed tedious and the need to mechanize the process was highlighted.

Patil *et al.* (2011) said that when new bunds were laid over existing paddy fields, the plough sole in the under bund soil profile was retained. This restricted downward percolation through bunds. They also stated that the soil was puddled in paddy fields so that finer soil particles in the suspension got deposited near the puddling depth. A plough sole, between 10 and 25 cm of soil depth was thus formed. Bunds or small dykes were constructed around paddy fields to offer restriction to the horizontal flow of water.

Several bund management methods such as concrete bund, gravel packed bund, concrete covered soil bund and plastic covered soil bund were also mentioned by Patil *et al.* (2011). However, most of these were expensive, difficult to implement and had an adverse effect on the environment.

As reported by Singh *et al.* (2016), bunds were formed in fields to demarcate boundaries and for irrigation purposes. In paddy fields, where there was presence of standing water, they also prevented leaching out of fertilisers.

Tractor operated bund formers are usually disc type, mould board type or forming board type. However, the bunds formed by these bund formers must be shaped and packed, which was usually performed using spade or feet. This activity was reported to be labour intensive and time consuming.

### **2.2.1 Machinery for Bund Formation**

Spoor (1969) reported that the soil engaging implements changed the state of the soil and the change produced depended on the nature of soil and the soil-implement interface. A soil engaging tool, which manipulated the soil to the required amount efficiently but with minimum effort was usually observed as the best design of the tool.

A power tiller operated bed former was developed by James (1991). The main components of the prototype were two pairs of forming boards fitted on a main frame, a hitching unit and a depth control-cum-transport wheel. Seed beds of heights 22, 18 and 15 cm were respectively formed at widths ranging from 60 to 64 cm. Heights of 18 and 15 cm were obtained for widths ranging from 73 to 75 cm and 80 to 81 cm respectively. The range of power utilization was from 0.586 to 0.771 hp and the range of draft was from 115.59 to 169.69 kg<sub>f</sub>. Wheel slip was found to range between 46.76 per cent and 77.1 per cent. The mean effective field capacity of implement was 0.0996 ha h<sup>-1</sup> and mean field efficiency was 46.3 per cent. The total cost of production of the unit was Rs. 2000/- and the cost of operation per hectare was Rs. 777/-.

A tractor operated multicrop ridge furrow opener and a flatbed seeding machine to plant seeds of different crops on, both flat beds and ridge-furrow system, was developed by Sharma *et al.* (2001). The implement had two bottom ridger-seeder, for making the ridges and furrows, with seeding adjustments to place seeds in furrows, on ridges or on the sides of ridges. Nine shoe type combined furrow openers were used in a single operation on flat beds. The implement had a field capacity of five to six hectare per day depending on the

crop type sown. The implement could achieve 30 to 40 per cent of savings in irrigation water and gave 12 to 15 per cent higher yields.

Bernik and Vucajnk (2008) mentioned that drawn cultivators/ridgers were suitable for well-structured light soils. They also reported that a number of scientists had demonstrated the use of PTO driven cultivators/ridgers in medium textured or heavy soils for potato cultivation. The PTO operated cultivators/ridgers created the largest cross-sectional area of the ridge, could crush soil aggregates in inter row spaces, was efficient in ridge shaping and led to lower cone resistances in the ridge centre. However, they required more energy to perform the same operation when compared to the drawn implements.

El-Ashry *et al.* (2009) developed a tractor drawn, five-ridge conventional seed drill, with six ridging bodies. The implement formed ridges 0.60 m wide and had a penetration angle of 20 degrees. Studies were conducted to evaluate the effects of different depths of ridge at 0.08 m, 0.12 m and 0.16 m, planting methods, forward speeds of 3.15 km h<sup>-1</sup>, 4.1 km h<sup>-1</sup>, 5.32 km h<sup>-1</sup> and 6.28 km h<sup>-1</sup> and number of rows of plant per ridge – single, double, three rows- on the crop yields. They concluded that the modified ridger cum seeder had a significant positive influence on plant height, germination ratio and number of branches per plant as compared to a traditional seed drill.

Nawale *et al.* (2009) developed an earthing-up cum fertilizer applicator for sugarcane that could be operated by a low hp tractor, for carrying out three operations, *viz.*, interculture, earthing-up and fertilizer application simultaneously. The developed machine weighed 250 kg and consisted of a ridger with sweeps for earthing-up, interculture unit with sweep type soil tool for off-barring of roots and interculture, fertilizer box of 60 kg capacity and ground wheel of diameter 40 cm. The average effective field capacity of the machine was 0.330 ha h<sup>-1</sup> with 82.70 per cent field efficiency. The average depth of operation was 10.20 cm with average ridge height of 22.35 cm. The

cost of operation was Rs. 88.99 h<sup>-1</sup> and there was a net saving of Rs. 3261.61 ha<sup>-1</sup> over the conventional method.

Pathirana *et al.* (2010) reported an A-frame design for bullock drawn and tractor drawn bund formers, as shown in Figure 2.1 (a) and (b), which were very simple in design and operation.

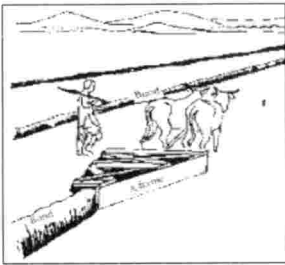

(a)

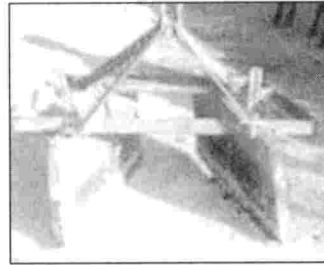

(b)

Fig. 2.1 Bund former – A- frame type (a) Bullock drawn A- frame (b) Tractor drawn A- frame (Source: Pathirana *et al.*, 2010)

Pathirana *et al.* (2010) also informed that the bund making attachments to tractors were available from the Chinese markets (shown below in Fig 2.2). These consist of rotary blades for breaking the existing bund or ground, and the implement collects the cut soil and compresses it with a rotating drum, to form new bunds, but are very costly. They also tried and tested the concept of a mud conveying channel – a curved and enclosed rectangular casing-like channel, with decreasing cross section - for conveying the loose mud of the paddy fields onto the bunds for plastering them, as is done during manual bund formation; but the results were not promising as mud stuck to the channel inside.

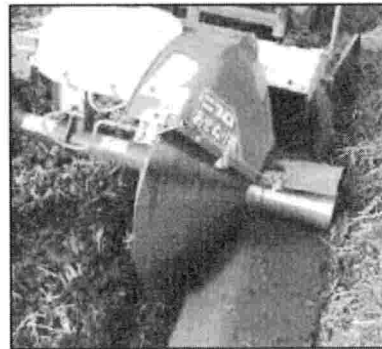
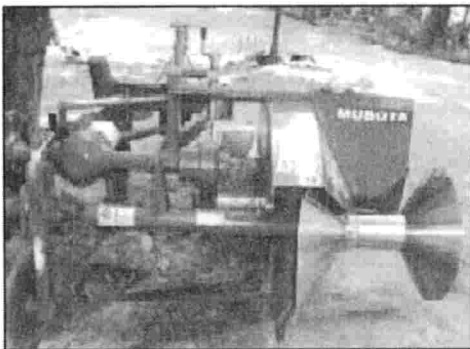

Fig. 2.2 Tractor operated bund making machines (Source: Pathirana *et al.*, 2010)

Gammoh (2011) developed a double-furrower with raised bed made up of a leveling blade 45 cm wide and two disc bottoms with 90 cm diameter each, which were mounted on an adjustable frame. This frame permitted the discs to slide horizontally in relation to each other. A furrow of depth 20 cm and width 50 cm was opened first by the front right disc. The soil so loosened was moved to form a ridge having a width of 50 cm and depth of 20 cm on the natural land level. The second furrow was simultaneously opened by the back left disc and the loose soil was thrown to fill the bottom of the first furrow, forming a raised bed.

Rajesh (2012) fabricated a tractor operated *kaipad* seedbed former. The height of seedbeds depended on the angle of the plough bottom, speed and depth of operation. Tests were conducted under dynamic conditions to optimize these three factors. Height of the seedbed was found to be maximum at 40° of the plough bottom. The seedbeds formed had the maximum height when the tractor was operated at a forward speed of 2 km h<sup>-1</sup> and depth of 0.20 m. However the operational speed and depth of operation was set at 1.5 km h<sup>-1</sup> and 0.15 m to reduce draft. The performance of the *kaipad* bed former and the tractor operated ridger were compared and it was observed that the average top width and heights of seedbeds obtained were 34.7 cm, 18.4 cm and 29.4 cm, 23.2 cm respectively. The *kaipad* seedbed former also had a field efficiency of 73.9 per cent with a wheel slip of 19.79 per cent.

Raghavendra *et al.*, (2013) developed a tractor drawn ridge planter for cotton. They reported an optimum performance at forward speed of operation of 1.25 m s<sup>-1</sup>, the average draft required was 2300 N and fuel consumption was 3.83 L h<sup>-1</sup>. The ridger planter had a field capacity of 0.89 ha h<sup>-1</sup> with field efficiency of 73.55 per cent. The planting depth was 30 mm.

An evaluation of the tractor operated ridge plastering machine (Model RRM700) was conducted at the ARS, Mannuthy, KAU. It was a PTO driven model using a chain drive with a slip clutch. It was observed that the machine

could perform satisfactorily only in a limited range of water content. The soil of the experimental plot was sandy loam. Proper bunds could not be formed in very dry or very wet soils. The machine was very heavy and required a higher draft. The machine could not develop sufficient power to till and form bunds in hard soils. The machine formed bunds of height upto 30 cm and had a field capacity of about one kilometer of bund formed per hour; and it cost about rupees four lakhs. (Joseph, S., personal communication, 2015; unreferenced). The weight of the machine itself would hinder its usage to form bunds in the soft soils of the *kole* lands.

A raised bed seed cum fertilizer drill for dry paddy was developed by Patil (2016). It consisted of seed and fertilizer hopper, seed metering mechanism, fertilizer metering mechanism, drive wheel, furrow openers, bed former, bed shaper and cut-off device. The implement formed beds with average top width, bottom width and depth of bed formed of 58 cm, 78 cm and 11 cm respectively with furrow width of 22 cm. The average depth of seed placement was 4.2 cm for raised bed system and 3.3 cm for flatbed system and fertilizer was placed at a 6.1 cm for raised bed and 4.9 cm for flat bed system. The operational speed of 2 km h<sup>-1</sup> was found better and the implement had a field capacity of 0.125 ha h<sup>-1</sup>, and field efficiency of 78.37 per cent.

A bund former cum packer was developed by Singh *et al.* (2016), which was made up of a disc type bund former, a rectangular tool bar frame and a packing unit, to carry out the operations of bund formation and packing in a single pass. The equipment had a field capacity of 1.4 ha h<sup>-1</sup> at a tractor speed of 2.93 km h<sup>-1</sup> and the labour requirement was reduced by about 96 per cent.

A tractor operated wide bed former, having a rotary tiller and a bed forming setup with a top width of 1000 mm and height of 130 mm, was developed and evaluated, at soil moisture contents of 12.5 to 16 per cent (db). A forward speed of 2.75 km h<sup>-1</sup> was found suitable for bed formation. The average

fuel consumption was found to be  $5.91 \text{ L h}^{-1}$  and field capacity  $0.31 \text{ ha h}^{-1}$  (Dixit *et al.*, 2018).

A former board type of bund forming implement was deemed to be suited to the paddy wetland conditions encountered in the *kole* lands.

## 2.3 PROFILE MEASURING DEVICES

### 2.3.1 Different Types of Profile Meters

In order to measure the roughness of soil surfaces in agricultural context, Kuipers (1957) developed a relief meter to measure the height of soil surface, relative to a datum line. The relief meter consisted of a frame, which housed 20 small dowel pins, 10 cm apart; which could freely slide up and down. The frame was placed over the soil surface to be measured and the dowel pins lowered to the surface. The distance moved by each pin from the reference line to the soil surface was noted to the nearest centimeter, from a scale mounted behind the pins. The 20 height readings measured at a given location were corrected for the mean of the readings at that location.

A dowel pin type relief meter, similar to Kuipers (1957) was developed by Allmaras *et al.* (1966) to determine a random roughness index. Twenty dowel pins, spaced two inches apart, were used to measure 20 height readings, across the direction of tillage. Readings were taken at 20 relief meter settings, spaced two inches apart in the direction of tillage, giving 400 readings on a 40 x 40-inch sample area. Of the 400 readings recorded, the upper 10 per cent and the lower 10 per cent of the values were not used in the calculations because of the possibility of erratic height readings. An estimate of the standard error of these corrected heights was used as an index of random roughness.

Though the pin meters are simple in design, and relatively easy to operate, the surface deformation caused due to the contact of the pins limit their use in the field. Non-contact type of devices were ideal for surface measurement as they could measure the true surface without causing deformation. An optical

device with laser diode, position sensing photo-detector and lenses (Harral and Cove, 1982), a non-contact meter using a light source and a sensor at a constant height above the soil surface (Romkens *et al.*, 1986), a portable tillage profiler (PTP) that consisted of a laser sensor to measure distance, a linear actuator, a portable PC, and a lightweight aluminum frame, and was capable of quickly and accurately measuring above ground and below ground soil disruption caused by tillage (Raper *et al.*, 2004), a portable meter capable of measuring depths up to 500 mm under typical field conditions (Kornecki *et al.*, 2008), a portable profile meter with image processing and tracking technique to measure changes in irrigation channel profile (Hegazy, 2013) etc., were some of the efforts in this direction.

Bernik and Vucajnk (2008) used a co-ordinate measuring device to measure the cross sectional area of the ridges formed by the different ridge formers tested in their study (Fig. 2.3). The device allowed absolute and relative measurements of distances within 1000 mm in transverse direction, 450 mm in longitudinal direction and 600 mm in vertical direction, with an accuracy of  $\pm 0.5$  mm. The measurements of the ridge dimensions were used to calculate the cross sectional area of ridges, making use of the Lab View computer program.

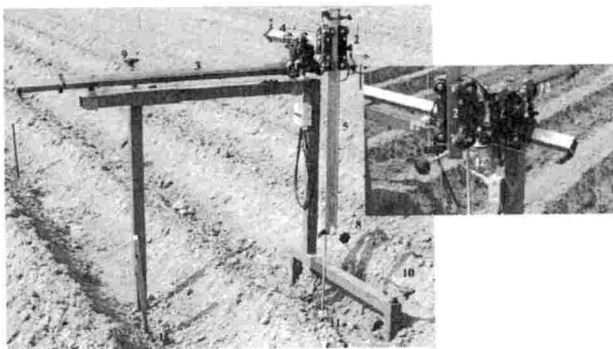

Fig. 2.3 Co-ordinate measuring device (Source: Bernik and Vucajnk, 2008)

The ploughing depth elevation of drainage channels was measured by the application of an ultrasonic sensor and ATmega 328 Arduino by Hariansyah *et al.* (2014), in their study, with the objective of developing an automatic mole



ploughing depth measuring device. The ploughing depth of the mole plough was controlled automatically. A green laser beam, placed at a set level, was directed onto a light receiver diode. As the position of the laser beam moved from the preset level, the program activated a relay which instructed a solenoid to open the valve and drag the mole plough to a defined point. The depth of ploughing was measured using the ultrasonic sensor which was sent into the Arduino micro controller, which permits the reading of data at the computer.

An automated device for measuring the values of nitrogen, phosphorus, potassium and pH of soil, to assess its fertility, was designed by Ananthi *et al.* (2014). Copper electrodes acted as sensors and measured the ionic particles present in the soil, which were converted into electrical signals. These signals were amplified and sent to the Arduino as a digital signal. The arduino processes the data received from the sensor, compares it with pre-stored values and displays the output regarding information on the soil fertility and crops to be grown, on a LCD display. The collected data is transmitted to the designate authority at a remote location through wireless transmission, for further analysis.

Devika *et al.* (2014) reported that they could develop an automatic plant watering system using arduino. The Arduino board used in the project consisted of AT mega 328 microcontroller which sensed the moisture level of the plants and supplied water if required. As plants required watering twice a day, the microcontroller was coded to water the plants about two times in a day. The prevalent conditions of the green house were read, and the refilling of water tank was also prompted, by the system.

Pushpa and Swathi (2014) designed a system capable of detecting moisture levels in the soil, the temperature inside and switching the water pump on and off using arduino. The arduino microcontroller controlled the operation of the water pump depending on the levels of moisture detected by the moisture sensors, and the speed of the fan by detecting the temperature using the temperature sensor.

Manoj and Udupa (2015) reported about the application of soil moisture sensor in mixed farming. They developed a device that detected the moisture level in soil when the device was placed in the field. It worked under three conditions wet, normal and dry conditions. If there was enough moisture in the soil, the device remained constant and it would not function. The device was interfaced with the water pump. When the sensors detected a dry condition, the device turned on the water pump until the soil moisture reached the normal condition.

Jena *et al.* (2015) designed a system for data acquisition of green house environment. Multiple sensors such as DHT11 sensor, soil moisture sensor etc. were used in green house to measure data. Better growth could be achieved in the green house by simulating and processing the data recorded by the sensors. Graphical User Interface (GUI) had been used through Lab VIEW Firm ware, Arduino Uno software and Arduino Uno board and sensors as hardware. Arduino Uno board enables multiple analog input and digital I/O. The sensor could thus easily read temperature, humidity, CO<sub>2</sub> gas readings, measure soil moisture that was needed for irrigation of plants, and the intensity of lights applied in green house. These parameters have a significant positive effect on growth of plants.

### **2.3.2 Sensors**

There are a wide variety of sensors available for distance measurement either directly or indirectly.

Kurt *et al.* (2008) described a planar laser distance sensor (LDS) that was comparable to laser scanners with three cm accuracy for 6 m, 10 Hz acquisition, and one degree resolution over a full 360 degree scan.

Mohammad (2009) reported that the ultrasonic (US) and infrared (IR) sensors can measure distances more accurately. They also stated that the IR and

US sensors can be used additionally to improve the overall vision systems of mobile robots.

Bach *et al.* (2012) reported the use of an Arduino microcontroller board to record the amount of time subjects spend in a particular location within a predefined distance with the date. It stored data for each incident on a micro SD card, which could then be transferred to a computer for interpretation. They demonstrated the possibility of the Arduino microcontroller board with an ultrasonic sensor as an accurate and anonymous method to measure proximity.

Mustapha *et al.* (2013) built an obstacle detection system which is based on ultrasonic (US) and infrared (IR) sensors, meant for use by people with vision impairment and the elderly. The system could detect different obstacle materials (e.g., wood, plastic, mirror, plywood and concretes) having a size of 5 cm x 5cm and colors, with an accuracy between 95 and 99 per cent. The experimental result indicated that the US and IR sensors are able to provide reliable distance measurements even with different colors and materials of obstacles.

Vigneshwari *et al.* (2013) developed an electronic navigation system for the purpose of enhancing mobility for the blind and visually impaired pedestrians. Ultrasonic sensors are employed for obstacle detection. The reflected real time signal was collected by the sensor and processed by the Arduino board. Appropriate decision was taken by the microcontroller based on the processed data. Then, a relevant message was invoked from the flash memory. Further this could be extended to deliver the decision to the subject via earphones.

Jamaluddin *et al.* (2015) developed a simple method for non-contact thickness gauging using ultrasonic sensor and android smartphone. This system is constructed using ultrasonic sensor HY-SRF05, microcontroller ATMEGA328, Bluetooth module and android smartphone. Ultrasonic sensor transmitted ultrasonic pulses in the form of waves and received back the pulses

after the waves were reflected by an object. The time duration between ultrasonic transmission and reception was calculated as distance between sensor and sample. The method for thickness measurement fixed the sample on a holder in front of the ultrasonic sensor. The thickness of sample was calculated based on distance between sensor to holder (fixed barrier) and sample to sensor. The zero position of measurement was distance of sensor to holder. The data of thickness was sent via Bluetooth and received by the android application. The android application used to display the measurement was designed based on MIT App Inventor for Android (AIA) platform.

Alattas (2014) developed a Postuino, used for posture correction, by using Arduino board and ultrasonic sensors. When a bad posture was detected, the user was notified. This system was designed specifically for computer users to prevent them from leaning too close to their computers' monitors. When the user leaned to the computer, the distance between him/her, the computer, and the Postuino accordingly fell below a certain threshold. An LED lighted up and Piezo speaker played a chosen melody at this point to alert the user to correct his/her posture.

Marathe *et al.* (2014) developed a portable automatic height detector which was basically designed to tackle the problem of accurate height measurement. The IR sensor perceives the distance of the object whose height or any other dimension needed to be determined. The signal was conditioned making the data suitable for further processing. The microcontroller Arduino Board was programmed to convert this input into the required height form for final display on the LCD. Heights of different objects were measured and displayed successfully with a low error of two per cent.

Monisha *et al.* (2015) discussed the measurement of distance without making contact with the target. This was done by generating 40 kHz ultrasonic waves using ultrasonic transducers. The distance was calculated on the basis on time taken by the pulse generated by the ultrasonic transducer to travel to the

target and return as reflected echo. This microcontroller was used for calculating the distance and displaying it on a seven segment display. A distance upto 2.5 m was calculated in air medium at ambient temperature.

Prabha *et al.* (2015) reported that the arduino with ultrasonic sensors can be used as accident avoidance system. They used ultrasonic sensors to detect any vehicle on both front and back side of the vehicle. The system envisages safety while reversing a vehicle, detects any object within specified distance, and displays the distance between one vehicle and another vehicle to the driver, using LCD. Safety can be maintained in crowded areas and during vehicle-reversing process.

Ankit *et al.* (2016) reported that ultrasonic sensor was most suitable for obstacle detection. It was low cost and had high ranging capability. They had developed an autonomous obstacle avoidance robot which was used for detecting obstacles and avoiding collision. The robot got information from surrounding area through sensors mounted on it. Some sensing devices used for obstacle detection were bump sensor, infrared sensor, ultrasonic sensor, etc. This arduino robot was controlled by an android mobile or tablet, with the help of an android app which could be down loaded from Google Playstore. The android application also connected to the Bluetooth module and sent desired commands.

Hence an ultrasonic sensor and Arduino technology was selected to be used for developing a low cost *in situ* profile measurement device.

## 2.4 SOIL AND MACHINE PARAMETERS

Many soil parameters are influential in a soil – machine environment. Soil properties are static or inherent to its nature, and dynamic, which come into play as it moves. The soil moisture content, bulk density, type of soil, the consistency limits, resistance to penetration and shear strength are factors which play an important role in the behavior of a soil working implement.

Bulk density of a soil is a function of soil moisture content at any given amount of compactive effort as reported by Hillel (1980). When wetness of soil increases, the inter-particle bonds are weakened. This led to swelling and reduction in internal friction, making soil more workable. When the soil neared saturation, the volume of air that could be expelled from the soil decreased and the soil could not be compacted to the same degree as earlier with the same compactive force. The soil wetness which is just enough to expel all air from soil is the optimum moisture content and the corresponding density is the maximum dry density.

Daddow and Warrington (1983) stated that root growth was stopped as the soil was compacted to the growth limiting bulk density values, because roots were not able to exert pressure to overcome this mechanical resistance and move the soil particles. The growth limiting bulk density of a soil was influenced by its texture, the property which affects the average pore size and mechanical resistance of compacted soil. A soil consisting of large amount of fine particles exhibits smaller pore diameter and greater penetration resistance at lower bulk densities. Coarse textures soils have a greater value of growth limiting bulk density as compared to fine textured soil.

Kepner *et al.* (1990) stated that implement work efficiencies were directly associated to the inherent physical and mechanical properties of soil such as moisture content, soil texture, shear strength, compaction and frictional forces.

Wet soils compacted easily till near saturation and then could not be compressed further. For the different soils in the study, the difference in soil compaction was greater at dry conditions, while soils in wet conditions showed greater changes on shear strength (O'Sullivan and Robertson, 1996).

Zadeh (2006) concluded that the energy consumed during tillage depends on soil, tool and operating parameters.

The soil cone index is the soil penetration resistance measured using a cone penetrometer. Kumar *et al.* (2012) listed that the cone index was an indicator for soil compaction, crop root development, soil water infiltration, draft on tillage tools, and performance of tractors.

#### 2.4.1 Measurement of Various Soil Properties

The hand driven instruments for measuring penetration resistance and shear strength are simple, cheap and easily portable, to the sites of data collection, and the data from hand driven equipment are easy to obtain. The measurements can be taken rapidly without destroying the sampling site. These are the only methods to measure the soil strength *in situ*. Zos and Grisso (2003) stated that cone penetrometer was a device that was easy to carry and was commonly used. The instrument worked only in wet and undisturbed soils. Soil cone penetrometer provided a combined measurement of soil normal strength and shear strength.

Tada (1987) illustrated the use of cone penetrometers in the measurement of soil strength. He reported that low bearing capacity of soils do not permit the use of tractors and combine harvesters in the paddy fields of Japan. The ploughed layer and plough sole layer determine the workability of machines. According to him, cone index values of penetration depicted the resistance, in  $\text{kg}_f \text{cm}^{-2}$  or MPa, offered by soil to the cone being pushed into it. This value was a measure of the bearing capacity of soil that determined whether particular farm machinery could be used in a field. The cone penetrometer was used to determine the cone index values. According to him, the shear strength could be determined by measuring the torque applied to cause soil failure, using the vane shear test.

The method of measurement of soil strength using the cone penetrometer was described by several researchers (Tada, 1987; Perumpral, 1987, Zos and Grisso, 2003). They explained that the penetrometer was to be held vertically over the point of measurement and pushed in slowly, using a penetration speed of about one  $\text{cm s}^{-1}$ . The readings of shear strength were to be recorded at each

depth of penetration; with at least three repeated measurements. Cone index of resistance to penetration is affected by soil water and management.

Mulqueen *et al.* (1977) evaluated penetrometers as a tool to measure soil strength. They found that penetration resistance increased with increasing soil bulk density.

Arvidsson *et al.* (2004) reported a method for measurement of depth of tillage in their study for assessment of specific draught of various implements at different water contents. They inserted a frame of 0.25 m<sup>2</sup> area into the tilled soil. All the loose soil within the frame was collected and weighed. The actual average working depth was calculated from the weight of the loosened soil and its bulk density. The draught force was divided by the product of the working depth and implement width to calculate the specific draught.

Bachmann *et al.* (2006) reported that the readings using the penetration resistance and vane shear equipment were similar. This suggested that the horizontal stress component was dominant for both vertical penetration resistance and shear resistance. Readings from both equipment could be used to represent horizontal stress at rest coefficient- a relative measure for the *in situ* soil strength state - which in turn was governed by the previous overburden load. Overburden load causes pre-compaction of the soil and this state of pre-compaction can be detected from the results of penetration resistance measurements and vane shear data. However, penetrometers are found to have a wider application than the shear vanes due to their ease of use in the field.

Ani *et al.* (2011) developed a low cost cone penetrometer using locally available materials as per the recommendations in ASAE standards. The developed penetrometer consisted of a handle made of half inch galvanized pipe, with a facility to be screwed on and off the pressure shaft, a graduated stainless steel pressure and penetration shaft, a spring loaded pressure chamber and a cone probe. The penetrometer performance was compared with that of the imported Proctor penetrometer in clayey loam soils. Twenty-four random samples on the



soil surface were tested for CI at 18 cm depth and the values were found to be 1.4358 MPa for the locally developed model, and 1.5096 MPa for the imported model. High degree of correlation obtained proved that the locally developed model could be used in place of the expensive imported model for *in situ* strength measurements.

Ramachandran and Jesudas (2017) used an instrumented hand held cone penetrometer to assess the soil strength. Soil physical properties and penetration resistance of soils at four locations were measured under wet rice field condition. Values of cone index were observed to decrease with increasing moisture content and increase with soil bulk density.

#### **2.4.2 Soil Parameters**

The physical properties and dynamic properties of soil, together, determine the behaviour of a soil, when it is subjected to deformation as in soil manipulation activities. Strength of soil is a dynamic property that comes into play when the soil is moved. Shear strength and resistance to cone penetration are of importance, as these affect the way a soil working implement behaves in the field. These properties are dependent on the soil characteristics also.

It has been reported by Smith (1966) that consistency is that property of cohesive soils which offers resistance to external forces tending to rupture or deform the soil aggregate. Consistency is a function of cohesion (or adhesion) of the clay particles which in turn is a function of moisture content. Pure cohesive soils obtain the bulk of their strength from the attraction forces of the minute water films surrounding the particles. Consistency is expressed as a function of the liquid limit in situ moisture content and plasticity index. Common terms used to express consistency are very soft, soft, firm, stiff or hard. For correlation purposes consistency is usually compared with the undisturbed strength.

Smith (1966) also reported that sensitivity, which is also important in determining the shear strength of cohesive soils, was defined as the ratio of the

undisturbed strength to remoulded strength at the same moisture content. It varied for different clays and also for the same clay at different moisture contents.

Gill and Berg (1967) defined dynamic soil properties as those properties that are manifested when the soil moves. Compacting a soil increased its soil strength, thus making soil strength a dynamic property. Soil strength was also explained as a property by which a particular soil could resist an applied force. It was also reported that compaction increases the mechanical strength of the soil.

Soil bulk density was defined as weight of wet soil per cubic centimeter and is calculated as per the IS:2720 (Part XXIX) – 1975 (Reaffirmed 2005).

Soil texture was defined as the relative proportion of the various size fractions present in a soil. It is an inherent property that is not subject to change. Soil water relationship, with regard to its storage, transmission, leaching, movement of nutrient ions and aeration etc. are governed to a large extent by texture. The International system classified the soil separates as coarse sand (2–0.2 mm), fine sand (0.2 – 0.02 mm), silt (0.02 – 0.002 mm), and clay (less than 0.002 mm). In the USDA system, the size fractions are very coarse sand (2.0 – 1.0 mm), coarse sand (1.0 – 0.5 mm), medium sand (0.5 – 0.25 mm), fine sand (0.25 – 0.10 mm), very fine sand (0.1 – 0.05 mm), silt (0.05 – 0.002 mm) and clay (less than 0.002 mm). Mechanical analysis is the analytical procedure by which the size fractions were separated and their percentage was determined in the laboratory (Jaiswal, 2006).

#### ***2.4.2.1 Penetration Resistance of Soil and Its Dynamics***

Soil properties such as moisture content, soil texture, bulk density and organic matter influenced the cone index values of soils, as reported in studies by Taylor and Gardner (1963), Camp and Lund (1968) and Perumpral (1987).

The association between soil cone index and depth, bulk density and moisture content was examined by several researchers (Ayers and Perumpral, 1982; Ohu *et al.*, 1988; Busscher *et al.*, 1995).

Two-parameter model relating compression index to void ratio and liquid limit have been derived by Al-Khafaji and Andersland (1992).

Soil compaction and plant root growth and development are affected by the value of soil cone index. Soil resistance can be used for calculation of compacting and loosening effects of farming implements (Bedard *et al.*, 1997).

Ayers and Perumpral (1982) reported a direct relation between bulk density and cone index. While Busscher *et al.* (1995) established an inverse relationship between cone index and moisture content, Ohu *et al.* (1988) found an exponential relationship between the two properties for loams and clays. Tillage practices and soil physical properties could be the reason for the non-uniform relationships reported. It was reported by Kumar *et al.* (2006) that there existed a cubic relationship between the cone index and depth.

Agodzo and Adama (2004) established correlations between moisture content ( $\theta$ ), bulk density ( $\rho$ ) and cone index ( $\Delta$ ) for four Ghanaian soils. Cone index and moisture content were related in the form of the equation  $\Delta = a\theta^2 + b\theta + c$  with very high correlation. The relationship between cone index and bulk densities was linear but the correlations decreased with increase in sand content of the soils.

Kumar *et al.* (2006) reported that the bulk density and penetration resistance are commonly used to evaluate soil strength in tillage studies, measurement of soil resistance being easier than measurement of bulk density. They studied the effect of various soil properties on the values of cone index. They found an increasing linear relation between the cone index and sand and silt fractions of soil under study but a decreasing trend of cone index with the clay

fraction. The cone index was found to increase linearly with bulk density also. Cone index values showed a decrease with the moisture content.

Lin *et al.* (2014) validated four semi empirical models developed by different researchers to predict bulk density as a function of measurement of cone index and moisture content. They developed a dual sensor vertical penetrometer (DSVP) which could simultaneously measure cone index and volumetric soil moisture content. The core-measured bulk density was compared model-predicted values using the DSVP data in silt loam and clay. The model developed by Ayers and Perumpral (1982) was modified to include the volumetric soil water content values as

$$CI = \frac{A_1 D_b^{A_2}}{A_3 + (\theta_v - A_4)^2},$$

where CI represents cone index in MPa,  $D_b$  is the bulk density in  $\text{g cm}^{-3}$ ,  $\theta_v$  is the volumetric soil water content in  $\text{g g}^{-1}$  and  $A_1$  to  $A_4$  are dimensionless coefficients to be determined in relation to the specific soil types.

Sayyedahmed (2015) reported the significance of the effect of moisture content, bulk density and penetration depth on the cone index values of sandy loam soils. The moisture content is a quadratic curve of second degree that is inversely proportional to cone index while bulk density and penetration depth were linear and directly proportional to cone index.

As per their study, Ramachandran and Jesudas (2017) observed that the penetration resistance in the upper layer of soil varied from 13.63 to 35 kPa in Wet Land of TNAU, Coimbatore (C-WL) and 6.3 to 40.57 kPa in Paddy Breeding Station of TNAU, Coimbatore (C-PBS). The lower layer showed a variation in penetration resistance between 145.03 and 200.36 kPa in C-WL and 88.17 and 200.64 kPa in C-PBS. In case of Aduthurai (ADT) and Bhavanisagar (BSR) sites, the soil strength profile was observed to be uniform and average penetration resistance varied from 67.66 to 166.73 kPa and 75.91 to 169.85 kPa respectively, at depth of 0 to 30 cm.

#### 2.4.2.2 *Shear Strength of Soil and Its Dynamics*

Shear strength is a dynamic property of the soil that is influenced by many factors including the soil type, moisture content, consistency limits, bulk density etc.

Liu and Thornburn (1963) established a relation between vane shear strength and moisture content, liquid limit, plastic limit, plasticity index and liquidity index of surface soils. From their studies, they concluded that the vane strength of a surface soil decreased with an increase in water content, and increased with increase in plasticity. They also found out that the field vane strength was affected twice as much by a one per cent change in moisture content, as compared to an equivalent change in plasticity.

As reported by Smith (1964), in fine grained soils, the shear strength is found to decrease with increasing moisture content, while the soil density decreases. When the soil moisture content increases, its state changes from brittle solid to plastic solid and then to viscous liquid state.

Smith (1966) in his study reported a work conducted by WES U. S. Army Engineering Corps in 1964, which stated that the vane shear strength and triaxial cohesion showed a good correlation for low values of shear strength and high degrees of saturation; and that the comparison of vane shear strength to triaxial shear strength exhibited a 1:1 relation, over the entire range of soil conditions.

Raghavan *et al.* (1978) reported that consistency limits could be used to predict the shear strength of compacted clay. A linear relationship was obtained between the shear strength and moisture content of the clay soil studied.

Ohu *et al.* (1985) studied the effect of organic matter present in soils, on the shear strength of the compacted soils. They found out that the soil shear strength increased with moisture content upto a maximum. Further increase in moisture contents brought about a decrease in shear strength. The soil shear

strength was measured on different tillage occasions using shear vane and penetrometer (Arvidsson *et al.*, 2004).

#### **2.4.2.3 Strength of Soil in Relation to the Consistency Limits**

Sorenson and Okkels (2013) proposed simple correlations between plasticity index and peak shear strength in undisturbed over-consolidated Danish clays of low to very high plasticity, that can be used as a first approximation for geotechnical structure design.

Roy and Dass (2014) have recounted that an increase in soil density causes a linear increase in shear strength. Densely packed soils show a higher strength for all textures and moisture contents. They informed that the shear strength parameters were in significant correlation with properties such as specific gravity, bulk density, natural moisture content, dry density, liquid limit, plastic limit and plasticity index; but no significant correlation was observed with coefficient of uniformity and coefficient of curvature. This, according to them, could be attributed to the poor gradation of particle size.

Raju *et al.* (2014) opined that the Atterberg limits of soils are related to the bearing capacity, swelling potential and shear strength of the soils, with the consistency limits having an influence on the strength characteristics. The strength decreases with an increase in plasticity index. The plasticity index was found proportionate to the respective liquid limit of the soil. They defined modified liquid limit and modified plasticity index based on the fraction of soil passing through the 425 micron sieve. It was also reported that that the optimum moisture content increases with the plasticity index.

Abdullahi *et al.* (2015) explained that the plasticity value (the difference between the water content at liquid limit and plastic limit) is an indicator of soil workability. When the plasticity value increases, the sensitivity to plastic deformation increases; a smaller value of the plasticity value indicates that the soil can be worked upon without much deformation.

Manuwa and Olaiya (2012) reported that cone index had a positive linear relationship with shear strength. However, a quadratic function with a higher coefficient of determination could also be fitted. Polynomial functions of second order described the effect of moisture content and applied pressure on cone index and shear strength, while linear, exponential and polynomial functions could be used to relate their effect on bulk density.

### **2.4.3 Measurement of Machine Parameters**

The measurement of draft using dynamometers has been reported by several scientists. In this method a digital dynamometer was used to measure the draft of the tractor-implement combination. An auxiliary tractor was used to pull the implement-mounted tractor through the digital drawbar dynamometer, which was mounted on the implement –mounted tractor, which is positioned in neutral gear with the implement in operating position. The tractor combination was operated for a distance of 20 m and draft recorded. Then the implement, attached on the second tractor was lifted off the ground and the operation repeated and draft recorded. Draft of the implement was calculated as the difference between the two readings (Ahaneku *et al.*, 2011; Rangapara *et al.*, 2017).

### **2.4.4 Machine Parameters**

The relative movement, in the direction of travel, at the mutual contact surface of a traction device and the support surface is termed as wheel slip (ASAE, 1983).

Slip on ground wheels, high planting speeds and non-uniform seed size were causes of irregular planting, as reported by Bjerkan (1947). They suggested an average value of slip as 5% for rubber tyres and 15% for steel wheels.

Zoerb and Popoff (1967) reported that maximum tractive efficiency is observed in the wheel slip range of 10 to 15%. When the slip increases beyond 15%, the fuel consumption is observed to increase, and the efficiency to decrease. Excessive slip also causes tyres to wear rapidly. In their study, they report the

different methods of slip measurement. In the conventional method of drive wheel slip measurement, first the base unloaded distance (B) for a given number of wheel revolutions was recorded. Then the loaded distance (L) for the same number of revolutions was also recorded. Percentage slip was calculated as equal to  $100 \times (B-L)/B$ . In another method stated by them, as per the University of Nebraska official drawbar test the total wheel revolutions to traverse a fixed distance is counted under load (R) and under no load (r) conditions and percentage slip is calculated as equal to  $[100(R-r)/R]$ . The equation is also a part of the Agricultural Tractor Test Code. A direct reading slip indicator was developed in the study.

For many small tillage and seeding equipment, that are operated at shallow depths, the draft force required to pull the implements depends on their width of operation and the speed of operation, while for deeper operating tillage tools, draft also depends on texture, geometry and depth of operation. (ASAE D497.4 MAR99).

As stated by many other researchers, Fernandes *et al.* (2007) also state that slip influences fuel consumption negatively; however it is required to increase the tractive efficiency and drawbar power. Hence an optimum range of slip is required for efficient tractor operation. Selection of radial tyres as against bias ply tyres, increase of number of tyres, monitoring of tyre wear, correct gear and engine speed etc. can reduce slip. They determined from their study that for a tractor with rated power of 89.7 kW, when slip is 18 per cent, there is a variation in fuel consumption of  $5.36 \text{ L h}^{-1}$ , which is about 23 per cent of the annual average fuel consumption value. Hence by reducing slip, the fuel consumption could be reduced.

Fathollahzadeh *et al.* (2010) cited the fuel consumption using mould board ploughs to be  $30 \text{ L ha}^{-1}$  in wet soils and  $23 \text{ L ha}^{-1}$  in dry soils. They also reported an average fuel consumption of  $30 \text{ L ha}^{-1}$  in common ploughing depth of 0.2 to 0.25 m, when a John Deere 3140 tractor was used with a three bottom



tractor operated mould board plough in loamy soils. They also found an increase in fuel consumption of the tractor with depth. Tayel *et al.* (2015) also reported the increase fuel consumption and slip with increase in soil moisture and tillage depth in sandy soils.

Brennenstul *et al.* (2015) reported a higher demand for power when tractor wheel was operated on non compacted soils as compared to sod. The total power required increased as vertical loads on the wheels increased, for both soils and sod, However, the increase was greater in case of soils.

Jebur and Alsayyah (2017) conducted a study in silt clay loam to study effect of soil moisture content and speed on slip, pull force and effective field capacity. They found that when soil moisture content was reduced from 18-20 per cent to 14-16 per cent, slip decreased by 31.34 per cent, and pull force decreased by 26.14 per cent but the effective field capacity was found to increase by 12.5 per cent. As the forward speed increased the wheel slip increased.

#### **2.4.4.1 Draft and Its Dynamics**

Draft was found to increase with depth of subsoiling (Reid, 1978; Wolf *et al.*, 1981). Reid (1978) found that when subsoiling depth was increased from 0.30 m to 0.41 m in sandy loam, an increase of 4.22 kN was observed per row, during operation of a subsoiler-bedder.

The effect of depth and speed on the draft required by various tillage tools, in three types of soils in Oklahoma were studied by Summers *et al.* (1986). He reported that the draft was in linear relation to depth of mould board plough, chisel plough, disc plough and sweep plough. A similar result was also reported by Khalilian *et al.* (1988), when they compared draft requirements between subsoilers and paraploughs.

Soil, operating depth, soil strength rate, inertial effect and wave propagation effect were found to be the major factors accounting for the increase in draft, when Zhang and Kushwaha (1999) studied the soil-tool interaction and

soil behavior. After a certain limit, it was seen that when the speed of a tillage tool increase, the draft requirement decreases. When the tool speed increased faster than the wave of soil stress propagation the plastic zone of soil in front of the tool decreased or even disappeared, theoretically. The soil cutting resistance decreased. Hence they opined that there would be an optimum speed at which the draft requirement would be lower.

As per Saunders *et al.* (2000), the draft forces on tillage tools based, as affected by present soil and operating conditions of the tillage tools, are important parameters for design and manufacturing tillage implements. These parameters include soil type and condition, moisture content and ploughing depth.

Mouazen and Ramon (2002) developed a numerical-statistical hybrid model for evaluating draught requirements of subsoiler in a sandy loam soil, as influenced by moisture content, bulk density and depth. It is reported that the draught force of a tillage implement increased with increased bulk density, because soil strength usually increases with bulk density.

In the study by Mouazen and Ramon (2002), draft force of a subsoiler was found to increase with wet and dry bulk densities. However when there was increase in moisture content, it decreased. A linear change of draft with moisture content was observed. Draft was a quadratic function of wet bulk density and a cubic function of dry bulk density. A decrease in draft with moisture content did not go beyond a moisture content of 17 per cent.

Specific draught as a function of soil cohesion showed a linear increase with a coefficient of determination of 0.63. A strong correlation between cohesion and moisture content was also observed. As water content decreased, the specific draught increased. It was closely related to soil cohesion derived from vane shear measurements (Arvidsson *et al.*, 2004).

Draft was affected by parameters such as depth of operation and speed of operation. With increase in speed and depth of operation of combination tillage

implements, their draft also increased (Sahu and Raheman, 2006). This was due to the higher soil resistance and larger volume of soil handled due to increase in depth and the higher force required for accomplishing the soil acceleration when speed of operation increased.

Manuwa and Ademosun (2007) experimented in a soil bin to assess the influence of soil parameters, cone index and moisture content on draught force and soil disturbance of model tillage tools. In the sandy clay loam soil studied, draught increased at decreasing rate as soil moisture content increased from 11 per cent to 22.5 per cent (dry basis) and followed a quadratic function. Quadratic regression equations also described the relationship between draught with cone index, an indicator of compaction.

In their study to evaluate the tractor – disc harrow dynamics in undisturbed loamy soils, Serrano *et al.* (2007) found that draught showed a quadratic relationship with the implement mass, soil type, speed, working depth and soil conditions. They also found a linear relation between fuel consumed per hectare and the specific draught for the range of four to nine  $\text{kN m}^{-1}$ , for dry undisturbed soils. They suggested a 25 – 33  $\text{kW m}^{-1}$  ratio of tractor power to implement width.

When Serrano and Peca (2008) studied the effect of forward speed on draught force required to pull a trailed disc harrow, they observed that the draught force needed increased with forward speed in a linear manner between speed of 3 to 9  $\text{km h}^{-1}$ .

Naderloo *et al.* (2009) reported that parameters such as soil type, operating conditions of tillage tools, moisture content, working width and depth and stability arrangement of implements and forward speed influence the draft forces acting on the tillage tools.

The draught requirement of stubble cultivator were estimated in two soil types – light sandy and sandy loam, at three operational speeds and two different

depths of loosening. The soil physical properties were characterized by cone index measurements. The results showed around 30% increase in draught force during work in clay soils as compared to sandy soils (Novak *et al.*, 2014).

Nkakini and Fubara-Manuel (2014) studied the effect of speed of disc plough and soil moisture variation on tractive force required. They found out that tractive forces decrease with increase in soil moisture content at constant tillage speeds. The optimum speed of operation obtained was  $1.94 \text{ m s}^{-1}$  in an optimum moisture range of 2.5 per cent to 25 per cent wet basis for the loamy sand soil under study. As the soil moisture and tillage speed increased the soil strength properties decreased, indicating that good soil tilth would not be obtained at moisture contents above and below this optimum moisture content. They established a linear relationship for predicting tractive force of disc plough under varying soil moisture contents and tillage speeds.

Mari *et al.* (2015) reported an increase in draught forces, of a mouldboard plough in a clay loam soil, as the speed and depth of operation increased. However as the moisture content of the soil increased, the draught forces decreased for the same speed and depth.

# **Materials & Methods**

## CHAPTER 111

### MATERIALS AND METHODS

This chapter explains the methodology adopted for the development of a tractor operated bund strengthening implement for paddy wetlands. The methods followed to study the performance of the bund strengthening implement at different locations, under different soil conditions, is described. Procedures adopted to assess engineering properties of soil, develop the instrumentation required, analyse the cost of operation and for data analysis are also explained. These are presented under the following sub headings:

1. Concept and preliminary studies
2. Determination of soil properties
3. Development of the bund strengthening implement
4. Development of profile measuring instrument
5. Performance evaluation studies

#### 3.1. CONCEPT AND PRELIMINARY STUDIES

In Kerala, the formation of bunds used for demarcating fields and for water management in paddy wetlands, is still done manually. Bunds are essential for proper field water, nutrient and crop management. The prevalent cultural practice is to trim and reinforce the field bunds before each growing season using manual labour. The labourers make use of spades to trim and plaster the bunds. Soil from the sides of the bund are cut and deposited over the central portion. The sides and top are then pressed by the blade of the spade to compact and shape the bund.

In the *kole* lands, fields are left fallow after harvest. These fields fill up with water during the monsoons, and remain inundated for five to six months. The field bunds, from the previous season, remain submerged till dewatering is carried out before the next crop (Plate 3.1 (a) and (b)). During this period, the bunds lose

their shape and only an outline is left. This remnant of the bund from the previous season is strengthened manually, by skilled male labourers.



Plate 3.1(a) *Kole* lands before dewatering



Plate 3.1(b) *Kole* lands after dewatering

The manual bund strengthening operation in the *kole* lands was studied at the Pullazhi *kolepadavu*. Spades are used by labourers to cut the soil from the

field, adjacent to the bottom of the bund. This cut soil was deposited over the existing bund and the operation was performed on both sides of the bund. The bund was then shaped to attain a trapezoidal cross section by drawing the blade of the spade on the top and sides. The size of such manually formed bunds varied from place to place. A skilled worker can make bunds of lengths of 375 m to 450 m per day (Plate 3.2).

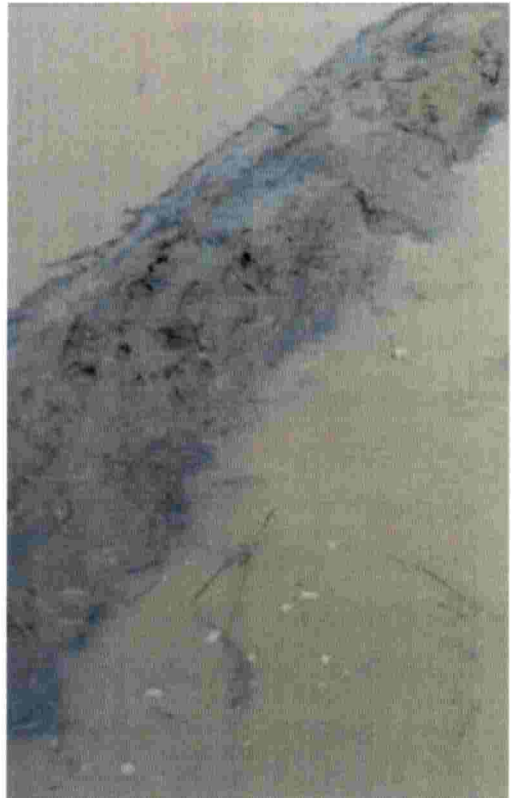
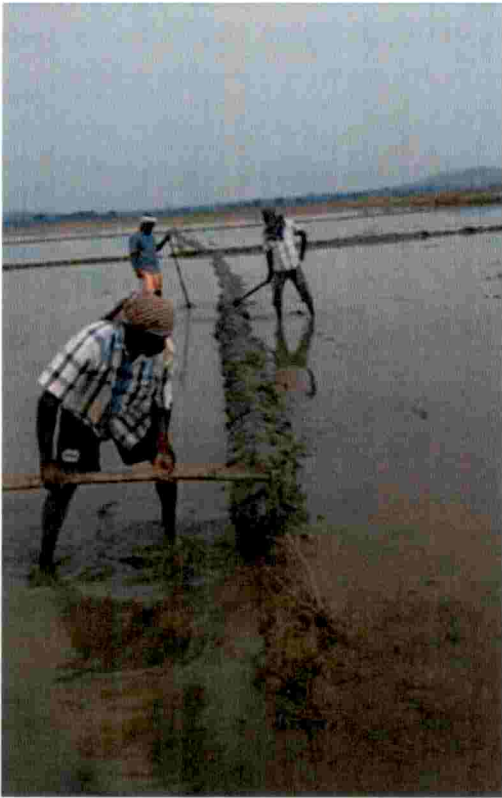

Plate 3.2 Manual strengthening of bunds and formed bund

Machinery is still not common for forming or strengthening the bunds in paddy wetlands. The tractor drawn ridge plastering machines, that are available in the market, have an average field capacity of 1000 m of bund per hour. But, the weight of the implement and the higher horse power required to operate it, are limiting factors for its use, especially in the *kole* and *kuttanad* wetlands of Kerala. It also requires exceedingly specific soil moisture content for proper bund formation.

64



The *kole* lands form the central rice bowl of Kerala, and large tracts are put under paddy cultivation every year. Here, mechanisation of cultivation practices is necessary to sustain paddy cultivation and ease the logistic and economic burden of the farmer. Though the labour intensive operations of tillage and land preparation, transplanting, harvesting etc. have been mechanised; one of the first field operations, viz., bund forming or strengthening, is still a manual operation, dependant on human labour. This operation is performed by male labour who currently charge Rs. 800/- to Rs. 850/- for an effective working day of six hours.

The paddy cultivation practices in the *kole* lands, are stringently time bound, and move forward through the different stages in a rhythmic and systematic pattern, over the entire *padashekharams*. Each *padashekhararam* has an area of approximately 200 ha and more. The tillage, bund forming, levelling and liming activities have to be completed within a maximum time period of seven to ten days, depending on the sequence of dewatering of fields, water level, availability of machinery and labour. The scarcity of skilled labour during the peak period of bund formation causes great difficulty to the farmers. This urges the need of development of a low cost implement to mechanise the operation of bund forming, in these vast wetlands. Hence, this study was taken up with an aim to develop a low cost, tractor operated, bund strengthening implement for paddy wetlands that could form bunds acceptable to the current farmers' practices.

The tractor operated bund formers, available in the market, are disc type, mould board type or forming board type. On review of literature, these types of bund formers have not been evaluated in the soil conditions typical of the *kole* lands or wetlands. However, certain implements have been developed for use in the *kaipad* rice cultivation - a rice cultivation practice followed in low lying and water logged areas of Kannur district of Kerala. The desired cross section of the bund being trapezoidal, it was decided to conduct preliminary studies to determine the suitability of identified available implements and power sources, for the operation of bund formation / strengthening in the *kole* lands/wetlands. The

preliminary field studies were conducted in the Pullazhi *kolepadavu* of Thrissur district.

### **3.1.1 Study-I: Assessment of Suitability of Power Tiller Operated *Kaipad* Bund Former**

As power tiller is the commonly used power source for tillage in the *kole* lands at Pullazhi, it was decided to assess the suitability of the power tiller operated *kaipad* bund former for forming bunds in the *kole* wetlands. The *kaipad* bund former was developed to form bunds of soil for raising paddy nursery in the *kaipad* rice fields which are also situated below MSL, similar to the *kole* lands. The power tiller operated *kaipad* bund former was operated on the existing bunds from the previous season (Plate 3.3).

### **3.1.2 Study-II: Assessment of Suitability of Mini Tractor Operated KAU Bed Former**

The suitability of a mini tractor as a power source for bund strengthening operations was assessed, in order to find an alternative to the power tiller. The reduced drudgery in operation of a mini tractor, improved traction, better manoeuvrability, controlled field movements, and higher power output, made it an attractive option over a power tiller. The ease of operation of a four wheel tractor considerably reduced the stress and fatigue of the operator.

The KAU bed former has been developed as an attachment to the KAMCO mini tractor, to take broad, trapezoidal beds for vegetable cultivation. It has two furrow openers, with adjustable spacing ranging from 0.30 to 0.45 m. It was felt that by reducing the spacing between the furrow openers to the minimum, it would be possible to form trapezoidal shaped bunds of the expected cross section. Hence, trials were conducted using the 11.5 kW, four wheel drive KAMCO TeraTrac, in combination with the KAU bed former attachment (Plate 3.4). The power source – implement combination was tried on a length of approximately 100 m.

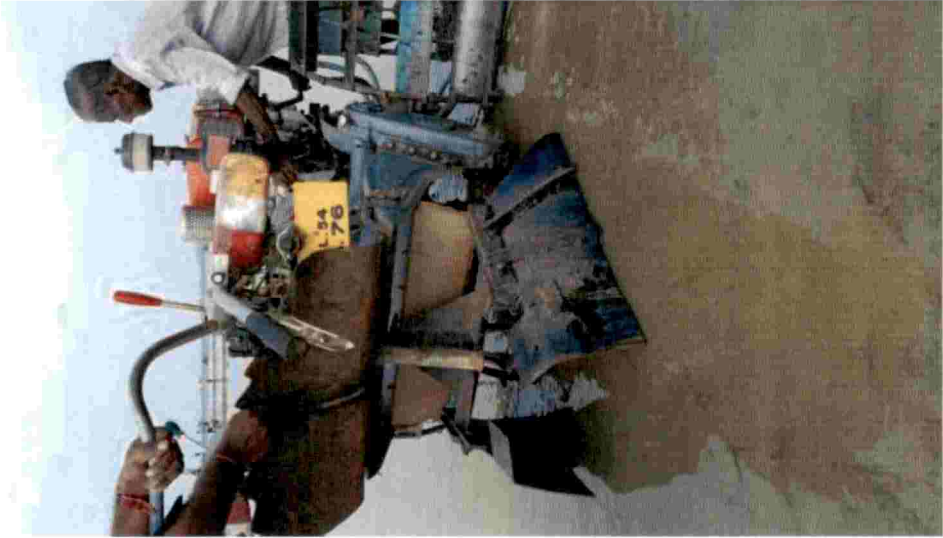

Plate 3.3 Power tiller operated *kaipad* bund former



Plate 3.4 KAMCO TeraTrac operated KAU bed former

### 3.1.3 Preliminary Soil Studies

Soil samples were collected from the Pullazhi *kole* lands, as per standard procedure, and the engineering properties of soil, relevant to the development of the implement, were assessed at the Soil Mechanics Laboratory of the KERI, Thrissur.

## 3.2 DETERMINATION OF SOIL PROPERTIES

### 3.2.1. Selection of Research Locations

Two *kolepadavus* – the Pullazhi *kolepadavu* in Thrissur *kole* lands of Thrissur district and Kolothumpadam *kolepadavu* in Ponnani *kole* lands of Malappuram district were selected for field testing and performance evaluation of the bund strengthening implement. A non *kole* paddy field at Athalur, Tavanur, Malappuram district was also selected as the test site. Soil samples from these areas were collected to determine the various soil properties.

The soil properties may be classified into physical and dynamic properties. The inherent soil physical properties observed in the study were the moisture content, particle size distribution and bulk density. The dynamic properties of the soil are the properties that come into play when a stress is applied to the soil and are expressed when soil moves due to externally applied forces. These include the plasticity, shrinkage, strength, resistance etc., which were observed in the study.

Three samples of soil each were collected from three locations, in each of the three test sites, viz., Pullazhi *kolepadavu* (PU1, PU2 and PU3), Kolothumpadam *kolepadavu* (PO1, PO2 and PO3) and Athalur, Tavanur (TVR1, TVR2 and TVR3), after dewatering and before land preparation for sowing. These samples were used to analyse the relevant soil properties which would throw light on the soil type and characteristics.

Soil properties were also measured after the formation of the bunds, to determine the strength characteristics. The procedures adopted for determination of the different soil properties are explained below.

### 3.2.2. Moisture Content

Moisture content of the soil is the amount of water within the pore spaces of soil grains which can be removed by oven drying at 105 °C, and expressed as a percentage of the mass of dry soil. The samples collected from the test locations were oven dried at 105 °C till they attained constant weight. The moisture content (dry basis) was calculated using the following formula:

$$w = \frac{M_w}{M_s} \times 100(\%)$$

where,

w = water content (dry mass basis), (%)

M<sub>w</sub> = mass of water, g

M<sub>s</sub> = mass of dry soil, g

### 3.2.3. Particle Size Distribution (Soil Texture)

Soil is referred to as the material passing through a 2 mm sieve. The particle size distribution analysis helps to determine quantitatively, the proportions (by mass) of the different sizes of particles present in a soil thus defining the soil texture. Soil texture is an inherent property of the soil. The textural class of the soil is determined, based on the relative proportion of the size separates, using the soil textural triangle.

The international pipette method (Robinson, 1922) was used to determine the soil texture. The equipment consists of 1000 ml glass sedimentation tubes, sampling pipette with pressure and suction inlet (Fig. 3.1), mechanical stirrer, beakers, stop watch and hot air oven. The reagents used include 30 per cent H<sub>2</sub>O<sub>2</sub>, and 1N NaOH.

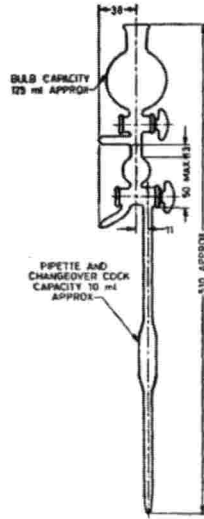

Fig. 3.1 Sampling pipette

The soil sample to be analysed was dried under shade. About 50 g of sample was passed through the 2 mm sieve. About 20 g of sample passing through the 2 mm sieve, was taken in glass beakers and 30 per cent  $H_2O_2$  was added to it, in increments of 5 ml. The contents of the beaker were stirred with a glass rod. Carbon di oxide evolution takes place due to the decomposition of organic matter, with occasional change of colour of the sample. After the initial expulsion of  $CO_2$  by manual stirring, the beakers were placed on a hotplate and the contents were gently heated (at  $30^\circ$  to  $40^\circ$  C) for 20 to 30 minutes to digest the organic matter and expel the  $CO_2$  completely. The process was repeated till there was only negligible evolution of  $CO_2$ . After the effervescence has stopped, the beaker was heated at a higher temperature for 10 minutes to expel the excess  $H_2O_2$ . Sufficient distilled water was added to the beaker before heating to ensure that the soil did not dry out upon boiling. The contents of the beaker were then cooled. This organic carbon free soil-water suspension was mixed thoroughly with 1 N sodium hydroxide and the contents were transferred to the dispersion cup of a motor operated stirrer. The contents of the dispersion cup were stirred at moderate speed for 20 minutes to complete the dispersion of soil particles. The room temperature was noted. The time required for twenty micron and two micron particles to settle down to a depth of 5 cm, from the initial level of suspension in the soil

sedimentation cylinders, were also determined from standard tables. The required times, as noted from the table, are two minutes and two seconds, and three hours and 24 minutes, at 26°C respectively. The steps involved in the determination of soil texture are shown in Fig. 3.2.

The contents of the dispersion cup were transferred completely into the 1000 ml soil sedimentation cylinder. The dispersion cup was washed with distilled water and washings also were transferred to the sedimentation cylinder and the volume made up to 1000 ml. After closing the mouth of the cylinder with a rubber stopper, the contents of the cylinder were thoroughly mixed by turning the cylinder upside down a number of times, for 60 seconds. The stopper was removed and the cylinder was immediately placed on a firm surface. The stop watch was also started at the same moment that the cylinder was placed on the firm surface, to initiate the sedimentation of mineral particles. Twenty seconds prior to the predetermined time, the pipette was lowered into the suspension in the sedimentation cylinder by lowering the adjustable pipette stand provided in the mechanical analysis pipette assembly. At the predetermined time, a 20 ml aliquot was pipetted out, to collect particles less than 20 micron in diameter. This was collected in a container; the pipette was washed with distilled water and the washings were also collected in the same container.

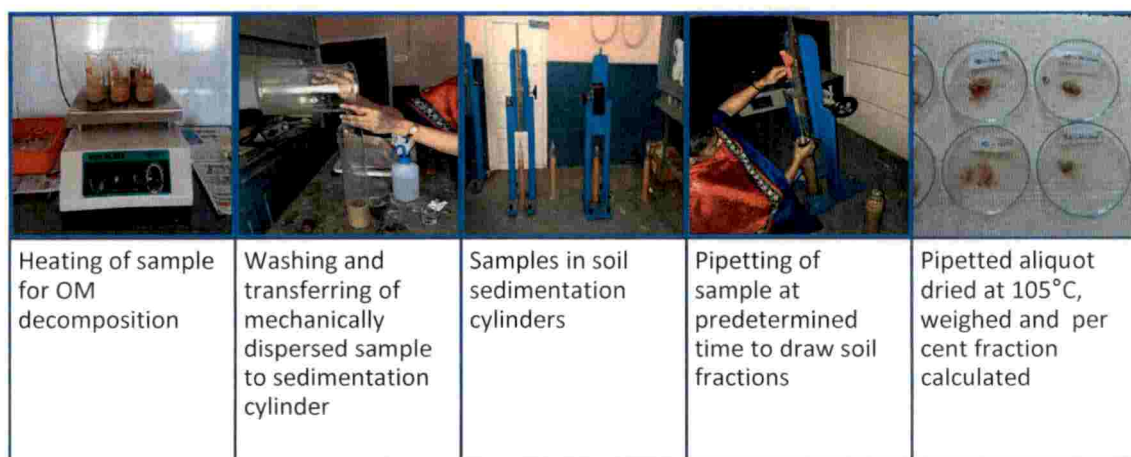

Fig. 3.2 Determination of soil texture

21

Similarly, another 20 ml aliquot was drawn out, at the same depth and at the predetermined time, to collect samples with particle size less than 2 microns in diameter. These contents were transferred to another container, the pipette washed and the washings collected in the container into which the aliquot was transferred. These containers were placed in an oven at 105°C and the contents evaporated, till they reached a constant weight. This took more than 48 hours in some cases. The dried samples were weighed and the percentage of silt and clay fractions was calculated as follows:

$$\% \text{ silt + clay} = \frac{\text{Mass of soil fraction} < 2 \text{ micron diameter} \times 1000 \times 100}{\text{Mass of organic free soil (g)} \times 10}$$

$$\% \text{ clay} = \frac{\text{Mass of soil fraction} < 2 \text{ micron diameter} \times 1000 \times 100}{\text{Mass of organic free soil (g)} \times 10}$$

$$\% \text{ silt} = \% \text{ silt + clay} - \% \text{ clay}$$

$$\% \text{ clay} = 100 - \% \text{ silt + clay}$$

All the samples were analysed in this manner for determining the particle size distribution. The analysis was carried out at the Soil Testing Laboratory of the Radio Tracer Laboratory, KAU. The texture of the soil was assessed by plotting the percentages of the sand, silt and clay particles in the USDA soil texture triangle.

#### **3.2.4. Bulk Density**

The bulk density of soil is the weight of soil divided by its total volume. It is an indicator of soil compaction. Higher bulk densities tend to restrict plant root growth. The apparatus used for measuring bulk density consisted of a hollow cylindrical steel core cutter, a dolly which fit on top of the core cutter, a rammer with a MS foot and a solid MS staff which was concentrically screwed on to the foot, a weighing balance and a palette knife. Bulk density was measured as per IS:2720 (Part XXIX), 1975. The inner volume of the core cutter was calculated.



Weight of the empty core cutter was noted. The core cutter was placed over the point of sampling, the dolly placed on it and the rammer was used to vertically ram down the core cutter into the soil. The core was then removed from the soil, without rocking it and the excess soil protruding out from the end was trimmed off. The weight of the core cutter with soil was noted. The bulk density ( $\gamma_b$ ), i.e., the wet soil weight per cubic centimetre, is calculated as

$$\gamma_b = \frac{W_s - W_c}{V_c}, \text{ g cm}^{-3}$$

where,

$W_s$  = weight of soil and core cutter, g

$W_c$  = weight of core cutter, g

$V_c$  = volume of the core cutter,  $\text{cm}^{-3}$

The dry bulk density ( $\gamma_d$ ) is calculated as follows:

$$\gamma_d = \frac{100\gamma_b}{(100 + w)}, \text{ g cm}^{-3}$$

where,

$\gamma_b$  = wet bulk density,  $\text{g cm}^{-3}$

w = moisture content, %

Bulk density values were determined for three soil samples each, collected from three locations, within each test site.

### 3.2.5. Soil Consistency Limits

Soil consistency is used to describe the actions of forces of cohesion and adhesion in soil at varying moisture contents. The strength of the connections between soil particles, in clay containing soils, varies with the moisture content and their behaviour depends on the moisture present. Consistency limits are the

moisture contents at which the soils show specific properties. The Atterberg limits are used for measuring the consistency of soils.

### **3.2.5.1. Liquid Limit**

The liquid limit ( $w_L$ ) is the moisture content at which the soil will barely flow under an applied force. It is the moisture content that separates the liquid and plastic condition of the soil.

Liquid limit of the soils at the test locations was determined using the Casagrande liquid limit apparatus. The apparatus consisted of a brass cup and a carriage mounted on a hard rubber base (IS: 2720-V). Two types of grooving tools, the ASTM and Casagrande (BS) types were used for the study. The required equipment also included a porcelain dish of 150 mm diameter, a palette knife 200 mm long and 30 mm wide, a 0.425 mm sieve, weighing balance with 0.01 g accuracy, thermostatically controlled oven, and air tight containers. The brass cup of the liquid limit apparatus was so adjusted that when it was raised to its maximum height, a 10 mm gauge would just pass between it and the base. About 200 g of air dried soil sample, passing through the 0.425 mm sieve was taken and mixed thoroughly with distilled water, in the porcelain dish, to a stiff and homogeneous paste. This was kept in an airtight container for 24 hours, to mature, and then remixed. A portion of this paste was placed at the centre of the brass cup, the cup was half filled and soil paste levelled with a spatula to a maximum depth of 10 mm. A clean, straight groove, about 2 mm wide, was cut in the paste, along the diameter of the cup through the centre of the hinge, by drawing the grooving tool firmly through it. The ASTM grooving tool is used in low plastic soils, while the BS grooving tool is used in other types of soil. The handle of the device was rotated at the rate of 2 revolutions per second to lift and drop the cup through 10 mm, till the two parts of the soil at the bottom of the cup come in contact for a distance of about 10 mm. The number of blows required for this was noted. Soil from the closed portion was removed for moisture content determination. Remaining soil was transferred to the porcelain dish, a small quantity of water

added and mixed thoroughly and the test was repeated. The apparatus for determination of liquid limit is shown in Plate 3.5.

The test was carried out from drier to wetter soil condition and at least four sets of readings evenly distributed in the range of 15 to 40 blows were noted.

The relation between water content and the corresponding number of blows was plotted as a semi log graph with percentage of water content as ordinate on the linear scale and the number of blows as abscissa on the logarithmic scale. A best fit straight line was drawn joining the points to form the flow curve and the water content corresponding to 25 blows, read from the graph, is the liquid limit. It is expressed to the nearest whole number.

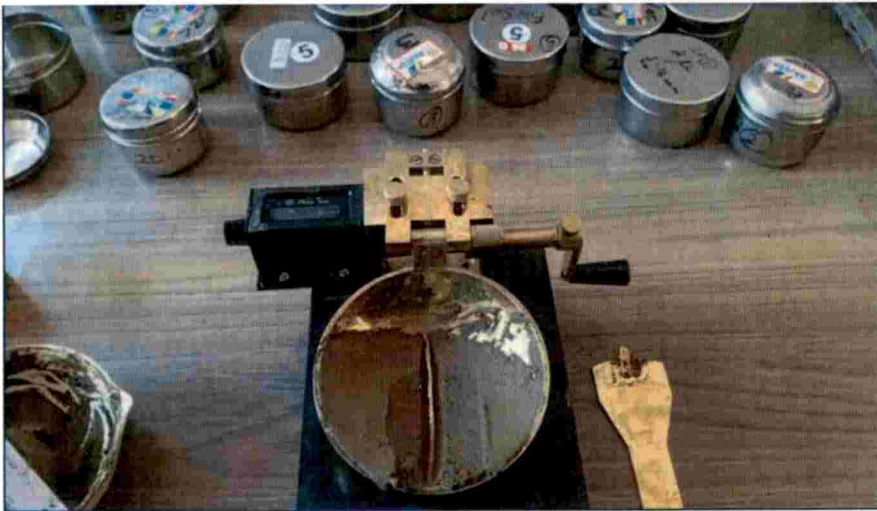

Plate 3.5 Determination of liquid limit

Samples were collected from the different trial locations and the liquid limit assessed as per the procedure stated, in the Department of Agricultural Engineering, College of Horticulture, Vellanikkara.

### **3.2.5.2 Plastic Limit**

The plastic limit is the moisture content at which “soil can barely be rolled out into a wire” or the lowest water content at which the soil transforms from plastic to rigid condition. To determine the plastic limit of the soil, a sample

passing through the 0.425 mm sieve was mixed thoroughly with distilled water to obtain a homogenous mass plastic enough to be shaped into a ball. A small ball of approximately 5 g was formed from this sample. It was rolled between the fingers of one hand and a glass plate with uniform and sufficient pressure to roll out a thread of 3 mm diameter. When the diameter was reached, the soil was remoulded and the procedure repeated till the thread just started to crumble. The diameter was compared with the standard gauge rod. The test was repeated thrice and the moisture content of the crumbled threads determined (Plate 3.6).



Plate 3.6 Determination of plastic limit

The average of the three water contents determined to the nearest whole number is reported as the plastic limit ( $w_p$ ). The plasticity index ( $I_p$ ) is calculated by the formula

$$I_p = w_L - w_p$$

The test to determine the plastic limit of the soils collected from the different trial sites was conducted in the Department of Agricultural Engineering, College of Horticulture, Vellanikkara.

### 3.2.5.3 Shrinkage Limit

A wet soil mass shrinks as it is dried, *i.e.*, its volume reduces to the same extent as the water is removed from it. Shrinkage occurs due to the capillary forces acting on soil surface. At certain moisture content, these forces cease to cause further reduction in volume of the soil mass. The water content at which

any further moisture reduction does not result in decrease in volume is called shrinkage limit ( $w_s$ ) (IS-2720 part VI).

From about 100 g of soil sample passing through the 0.425 mm sieve, about 30 g was taken and mixed thoroughly with distilled water to fill all the voids with water, so that the soil could be easily worked into the shrinkage dish without entrapping air bubbles. The mass and volume of the shrinkage dish were determined; the volume being determined by the mercury displacement method. The inside of the shrinkage dish was greased and soil paste was filled upto one third of the capacity of the dish at a time. The dish was tapped to remove all entrapped air and the procedure repeated till the shrinkage dish was completely filled with soil paste. The excess was trimmed off. After determining the wet mass and volume of the soil pat, the shrinkage dish was placed in the hot air oven at 105°C for 24 hours to determine the mass of the dry soil pat. The volume of the dry soil pat was determined by placing the dry soil pat on the surface of mercury filled in a glass dish, whose mass had been observed previously. The dry soil pat was immersed in mercury using the three-pronged glass plate. The displaced mercury was weighed and the volume of the dry soil pat calculated by dividing the mass by the density of mercury ( $13.6 \text{ g ml}^{-1}$ ) (Plate 3.7).



Plate 3.7 Determination of shrinkage limit

The shrinkage limit (%) was calculated by the formula

$$w_s = \left[ w - \frac{V - V_d}{M_s} \right] \times 100$$

where

- w = water content of the wet soil pat
- V = volume of the wet soil pat, ml
- $V_d$  = volume of dry soil mass, ml
- $M_s$  = mass of dry soil pat, g

Shrinkage limit was calculated for the soil samples collected from three locations at each of the test site. Three samples each were collected from each location within every test area.

### 3.2.6 Penetration Resistance (Soil Resistance)

Soil penetration resistance is an indicator for compaction of the soil. The cone index, an index of soil strength, which is recorded using a cone penetrometer, is defined as the force per unit base area, expressed in  $\text{kg cm}^{-2}$  or Pa, required to push the penetrometer through a specified small increment of soil depth (ASABE, 2011a,b). The cone penetration resistance over a depth range has been termed as cone index (ASAE Standard, 313.3). The cone penetrometer, with a standard SS cone of  $30^\circ$  cone angle and a base area of  $6.45 \text{ cm}^2$ , and digital indicator for reading the values, was used for the study (Plate 3.8).

The penetrometer was held vertically over the soil surface where the reading is to be taken. It was slowly and evenly pushed into the soil at a penetration speed of about  $1 \text{ cm s}^{-1}$ . The penetration resistances obtained were recorded against the depth of penetration, upto a depth of 300 mm. The initial reading was taken when the base of the cone was level with the soil surface. The subsequent readings were observed at incremental depths of 25 mm upto 300 mm.



Plate 3.8 Set up for measurement of cone index

The cone index ( $q_c$ ), in  $\text{kg cm}^{-2}$ , was calculated using the following equation (Tada, 1987)

$$q_c = \frac{(F + W)}{A}$$

where

$F$  = applied force,  $\text{kg}_f$

$W$  = weight of the cone penetrometer,  $\text{kg}_f$

$A$  = base area of the cone,  $\text{cm}^2$

Five sets of readings were taken at random locations within each of the identified test areas and the cone index values were calculated as above.

### 3.2.7 Shear Strength

The characteristic strength of a soil is its shear strength. Shear strength permits a body of soil to remain in a slope. It is determined *in situ* by using the vane shear apparatus.

The vane shear test determines the peak and remoulded shear strength of the soil. A four-bladed vane, as per the ASTM D2573, with sharp tapered edges, was attached to a 12.7 mm diameter rod. The vane was advanced into the soil to be tested, to the required depth, and torque was applied from the surface at a rate of 0.1 degrees per second till soil failure occurs. After the peak value of torque, which is related to the peak strength, was noted, the vane was quickly rotated about ten times to remould the soil. The procedure was repeated and the torque was measured to obtain the remoulded soil strength. The sensitivity was calculated as the ratio between the peak and the remoulded strength. The vane was then further advanced to the next depth of measurement and the procedures were repeated. The maximum torque measured was used to calculate the shear strength using the formula

$$S_u = \frac{T}{K}$$

where

- $S_u$  = shear strength of soil, kPa
- $T$  = torque, N.m
- $K$  = constant, depending on dimensions of the vane  
=  $(0.00000388 D^3 - 0.00000076), m^3$
- $D$  = diameter of the vane, cm



The vane shear strength of the formed bunds was determined at three depths, viz., 0.20 m, 0.40 m, and 0.60 m, at the three trial locations. The readings were replicated three times to obtain an indication about the shear strength of soil.

### 3.2.8 Organic Matter

Soil organic matter is the organic fraction of soil, including plant, animal and microbial residues, fresh and at all stages of decomposition, passing through the two mm sieve along with the soil particles. Carbon is the major constituent of soil organic matter, comprising from 48 to 58 per cent of the total weight. Hence determination of organic carbon is used to estimate soil organic matter by multiplying the organic carbon value by a factor of 1.724 (Van Bemmelen factor). This factor is based on the assumption that the organic matter contains 58 per cent organic carbon. Organic carbon of the soil was determined by the chromic acid wet oxidation method (Walkley and Black, 1934).

The soil sample is ground using ceramic or glass mortars so as to enable it to pass through a 0.5 mm sieve. Soil sample, less than 10 g in weight, is weighed and transferred to a 500 ml wide mouth conical flask. Ten ml of 1N  $K_2Cr_2O_7$  is added and soil is dispersed in the solution. Twenty ml of concentrated  $H_2SO_4$  is rapidly added, and the flask is swirled to mix the reagents. The flask is allowed to stand on a sheet of asbestos for about 30 minutes. Two hundred ml of water is then added to the flask, as also 3-4 drops of ferroin indicator. The solution is titrated 0.5N ferrous ammonium sulphate. The solution takes on a greenish cast near endpoint and then changes to a dark green. At this point ferrous ammonium sulphate is added drop by drop until the colour changes sharply from blue to red. The calculations for per cent organic carbon are as follows:

$$= \frac{(\text{meq } K_2Cr_2O_7 - \text{meq } Fe(NH_4)_2SO_4) \times 0.003 \times 100 \times 1.3}{\text{g water free soil}}$$

$$= \frac{\{10 \times 1 - \text{Titre Value (mL)} \times \text{Normality of } Fe(NH_4)_2SO_4\} \times 0.003 \times 100 \times 1.3}{\text{g water free soil}}$$

81

$$= \frac{\{10 \times 1 - \text{Titre Value (mL)} \times \text{Normality of Fe(NH}_4\text{)}_2\text{SO}_4\} \times 0.39}{\text{g water free soil}}$$

Three samples were collected randomly from each test site. These were analysed for organic carbon using the method described above. The organic matter content was also calculated.

### 3.3. DEVELOPMENT OF THE TRACTOR OPERATED BUND STRENGTHENING IMPLEMENT FOR PADDY WETLANDS

In Pullazhi *kolepadavu* and neighbouring Adat *Naalumuri kolepadavu*, the observed bund size ranged from 0.12 to 0.15 m in height, 0.10 to 0.15 m in top width and the bottom width ranged from 0.20 to 0.25 m. The shapes of these manually formed bunds are highly irregular, but the cross section of the bund was generally trapezoidal. Hence, based on the prevailing cultural practices, the following fundamental points were taken into note for the development of the bund strengthening implement:

- the formed bund should have a trapezoidal cross section with a height of 0.15 m, top width of 0.15 m and bottom width of 0.25 m
- the implement should cut soil from both sides of the existing bund, throw it on top, and plaster the bund to form its shape
- the implement should be hitched to, and drawn by a mini tractor
- the implement should be easily attached to the power source and detached from it

After the preliminary trials conducted with power tiller operated *kaipad* bund former and the KAMCO TeraTrac mini tractor operated KAU bed former, it was decided to:

- develop a forming board type of bund former for strengthening the bunds
- adopt a trapezoidal cross section for the resultant bunds, with dimensions 0.15 x 0.25 x 0.15 m (top width x bottom width x height), as these were prevalent in the fields at the test location and were the farmers' practice

- use the mini tractor as a power source in place of power tiller, as it developed better traction, allowed better manoeuvrability (and therefore could form straight bunds) and reduced the drudgery that is involved in operating the power tiller

### **3.3.1. Development of the Bund Strengthening Implement – Initial Design Considerations:**

The following points were taken into account for developing the bund former.

1. The dimension of the bunds formed by the bund former must suit farmers' practice. Hence the dimensions 0.15 x 0.25 x 0.15 m (top width x bottom width x height) were selected.
2. The bulk density values obtained from the test results of KERI, Thrissur ( $1.6 \text{ g cm}^{-3}$  and  $1.74 \text{ g cm}^{-3}$ ), were used for calculation of the cutting width of the former.
3. The bulk density of the bund to be formed was assumed as  $1.8 \text{ g cm}^{-3}$ .
4. Remnants of the bunds from the previous season were already present in the field, and new bunds are formed by cutting soil and depositing the cut soil above these. Hence, 50 per cent of additional soil is assumed to be present on the ground on account of the remnant bunds.
5. Depth of cut is assumed as 0.06 m.
6. Mass of soil per metre length of bund formed and cut from field are assumed to be equal.

Based on the above points, the cutting width of the bund former was calculated and are presented in Table 3.1. It was decided to adopt a front cutting width of 0.35 m for the forming board type bund strengthening implement.



Table 3.1. Design steps for development of the bund strengthening implement

Sl. No.	Particulars	Symbols / formula	Value	Remarks
1	Dimensions of the final bund			
	Top width, m	$L_1$	0.15	
	Bottom width, m	$L_2$	0.25	Farmers' practice
	Height, m	$h$	0.15	
2	Cross sectional area (CSA) ( $m^2$ )	$0.5 \times (L_1 + L_2) \times h$	0.03	
3	Cross sectional area (CSA) ( $cm^2$ )		300	
4	Volume of bund per m length ( $cm^3$ )	$CSA \times 100 \text{ cm}$	30000	
6	Bulk density of the formed bund ( $g \text{ cm}^{-3}$ )		1.8	Assumed
7	Mass of soil per m length (kg)	$\text{Volume (cm}^3\text{)} \times \text{BD of formed bund (g cm}^{-3}\text{)} / 1000$	54	
8	Depth of cut (cm)		6	Assumed based on field trials

Based on the observed value of bulk density in the field soils, two conditions for the design are considered

Table 3.1. Design steps for development of the bund strengthening implement (contd..)

Sl. No.	Particulars	Symbols / formula	Value	Remarks
<b>Case (i)</b>				
9	Bulk density of bund to be formed, g cm <sup>-3</sup>		1.6	Values of bulk density ranged from 1.6 to 1.74 g cm <sup>-3</sup> from KERI tests' result
10	Volume of soil to cut per m length, cm <sup>3</sup>	Mass / density x 1000	33750	
11	Width of soil to cut, cm	Volume of soil / Depth of cut x soil per m length	37.5	Assumption: Additional 50 per cent soil present due to remains of previous season's bund
<b>Case (ii)</b>				
13	Bulk density of bund to be formed, g cm <sup>-3</sup>		1.74	Values of bulk density ranged from 1.6 to 1.74 g cm <sup>-3</sup> from KERI tests' result
14	Volume of soil to cut per m length, cm <sup>3</sup>	Mass / density x 1000	31034.48	
15	Width of soil to cut, cm	Volume of soil / Depth of cut x soil per m length	34.48	Assumption: Additional 50 per cent soil present due to remains of previous season's bund
16	Hence, front cutting width of bund strengthening device (cm) =		<b>35.00</b>	

es

### **3.3.2. Development of the Bund Strengthening Implement – Stage I**

Based on the above considerations, the first model of the bund strengthening implement was developed with a tool frame and hitch assembly, implement frame, forming boards and rear forming plate/ press plate

#### **3.3.2.1 Tool Frame and Hitch Assembly**

The rectangular tool frame had a length of 1030 mm and width of 500 mm. It was made of 65 mm x 65 mm x 6 mm MS angle bar lengthwise, and 50 mm x 50 mm x 5 mm MS angle bar width wise. The implement was fixed on the frame and this assembly was hitched to the tractor's three point linkage using standard hitch brackets.

#### **3.3.2.2 Implement Frame**

The frame of the implement consisted of two numbers of 35 mm x 35 mm x 3 mm MS angle bar, 450 mm long and 336 mm apart. Two risers, made of 25 mm x 25 mm x 3 mm MS angle bar, were welded on the outer surface of each forming board and attached to these MS angle bars, to complete the implement frame. This frame was screwed on to 1000 mm long, 150 mm wide, and 8 mm thick MS plates on the front and rear end, and then attached to the tool frame.

#### **3.3.2.3 Forming Boards**

The forming boards cut and gather soil from the sides of the existing bund, deposit it on top, and give shape to the bund. The rectangular forming boards, 400 mm long, were cut from 6 mm thick MS plates and were tapered in the front to provide for easy soil penetration. The boards were arranged in such a manner that the front top width was 220 mm and bottom width was 350 mm. The spacing between the boards at the rear was 150 mm at the top and 250 mm at the bottom to match the prevalent farmers' practice. The height of the forming boards was fixed at 150 mm. The forming boards were connected to the implement frame through the risers welded on them, to form a converging trapezoidal shape.

### 3.3.2.4 Rear Forming Plate / Press Plate

A rectangular forming plate or press plate, 200 mm x 100 mm size and made of 4 mm thick MS plate, was fixed to the rear of the forming boards. This joined the two forming boards and projected outwards. This was provided in order to press onto the top surface of the bund formed by the forming boards. The aim of the press plate was to provide a smooth finish to the surface of the formed bund.

The implement (Plate. 3.9) was operated using the KAMCO TeraTrac mini tractor as the power source, and tested at the Pullazhi *kole* lands. When the implement was operated over the pre-existing bunds, the front edge of the forming boards cut the soil from both sides of the existing bunds. This soil was carried along the forming boards and compressed into the reduced trapezoidal cross section at the rear of the former. The implement was used to form about 50 m of bund in fields of Pullazhi *kolepadavu*.



Plate 3.9 Initial model of the bund strengthening implement with rear press plate

### 3.3.3. Development of the Bund Strengthening Implement – Stage II

A rear forming case, with the same trapezoidal cross section as of the required bund, was fabricated and fixed to the rear of the developed bund former. The forming case further packed the soil that had been already formed by the forming boards, by making it travel through a confined area. This helped to strengthen the bund and to smoothen its surface.

Rear forming cases, having a trapezoidal cross section, with size 150 mm top width, 250 mm bottom width and 150 mm height and lengths of 200 mm, 400 mm and 600 mm were fabricated. These three forming cases were fitted, separately, to the main bund former body using nuts and bolts and were tested in the field. Bunds of approximately 50 m length each were formed using these rear forming cases at Pullazhi *kolepadavu*. Plate 3.10 shows the bund strengthening implement fitted with the rear forming case. Trials were carried out at the Pullazhi *kolepadavu* using the modified model of the bund strengthening implement.



Plate 3.10 Bund strengthening implement fitted with rear forming case



### 3.3.4 Development of the Bund Strengthening Implement – Stage III

The developed model of the bund strengthening implement was tested using KAMCO TeraTrac mini tractor at Kolothumpadam *kolepadavu* in the Ponnani *kole* lands (Plate 3.11). Approximately 30 m of bunds were formed here. Observations of the sizes of manual bunds prevalent in the fields were also made.



Plate 3.11 Bund formation at Ponnani *kole* fields

### 3.3.5 Development of the Bund Strengthening Implement – Stage IV

Bunds in the Ponnani *kole* lands were of larger dimensions. Hence bund strengthening implement to suit the conditions of the Ponnani *kole* fields also was to be developed. The bulk density values of the field at Ponnani ranged from  $1.83 \text{ g cm}^{-3}$  to  $1.86 \text{ g cm}^{-3}$  and had a higher percentage of clay content, as compared to soils at Pullazhi *kole* lands. As the bund former was operated in the field, a paucity of soil was also observed in the bunds at places. This could be due to the wide variability in the soil conditions and the dimensions of the pre-existing bunds. In the fields at Pullazhi *kole* lands, it was observed that the pre-existing bunds were almost non-existent at some places, while at others they had a central height of 100 mm or more. The dimensions of the pre-existing bunds at Ponnani

were also variable, and were covered with weeds. The bulk density of the soil was also found to vary, even within the field. Based on the results of the field tests conducted with the initial models of the bund strengthening implement, it was decided to develop three units, with differing dimensions, to suit these varying field conditions.

Based on the earlier assumptions and observations, the dimensions of the three models of the bund strengthening implement – BF1, BF2 and BF3 - were calculated. The major design considerations and dimensions of the three units developed are presented in Table 3.2. The main parts of the developed implements were the tool frame and hitch assembly, implement frame, modified forming boards and forming case.

#### ***3.3.5.1 Tool Frame and Hitch Assembly***

Modifications were made to the tool frame to permit use of the same tool frame and hitch assembly for both the KAMCO TeraTrac mini tractor and the tractors with higher horsepower. The dimensions of the rectangular tool frame were fixed as 1150 mm x 500 mm. It was made of 71 mm MS square, and 65 mm x 65 mm x 8 mm MS angled bar. The implement and the standard hitch brackets were fixed on the frame and the assembly was hitched to the tractor's three point linkage (Fig. 3.3).

#### ***3.3.5.2 Implement Frame***

The frame of the implement was fabricated as earlier, with two horizontal members made using MS angle bars. Risers, also made using MS angle bar, were welded on the outer surface of each forming board and attached to these horizontal members, to complete the implement frame. This frame was screwed on to the 1000 mm long, 150 mm wide, and 8 mm thick MS plates on the front and rear end, and then attached to the tool frame, as in the earlier model. Slots were provided in the MS plates, so that the position of the implement frame could be adjusted on it, as per the dimensions of the model being attached.

Table 3.2 Design considerations and major dimensions of three models of bund strengthening implement

Sl. No.	Particulars	Values		
		<b>BF1</b>	<b>BF2</b>	<b>BF3</b>
1	Required top width of the bund formed (cm)	15.00	20.00	25.00
2	Required bottom width of the bund formed (cm)	25.00	35.00	40.00
3	Required height of the bund formed (cm)	15.00	15.00	25.00
4	Volume of soil per metre length of bund (cm <sup>-3</sup> )	30000.00	41250.00	81250.00
5	Mass of soil per metre length of bund (kg)	57.00	78.375	162.50
6	Bulk density of field soil (g cm <sup>-3</sup> )	1.74	1.44	1.85
7	Expected bulk density of the formed bund (g cm <sup>-3</sup> )	1.90	1.90	2.00
8	Depth of cut (cm)	6.00	6.00	6.00
9	Additional soil existing above ground level on account of previous season's bund (%)	30	5	30
10	Volume of soil required to be cut (cm <sup>-3</sup> )	32758.60	54427.10	87837.80
11	Front cutting width of the bund former calculated (cm)	42.00	86.39	112.62
12	Front cutting width of the bund former selected (cm)	45.0	90.0	115.0

### 3.3.5.3 Modified Forming Boards

The forming boards were modified by adding a soil gathering board to the front of the forming boards used in the earlier model. These gathering boards were used to achieve a wider cutting width and hence more quantity of cut soil, which

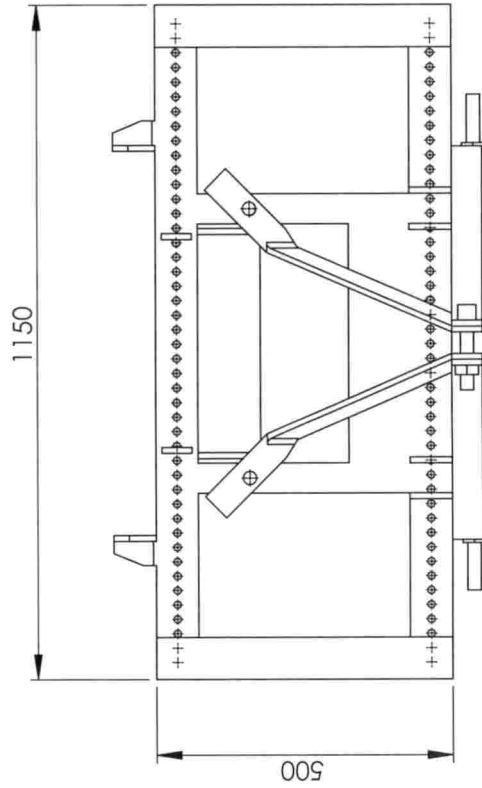
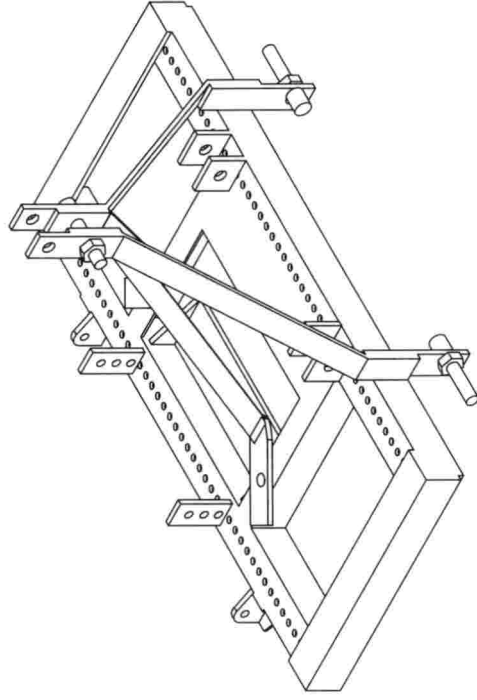
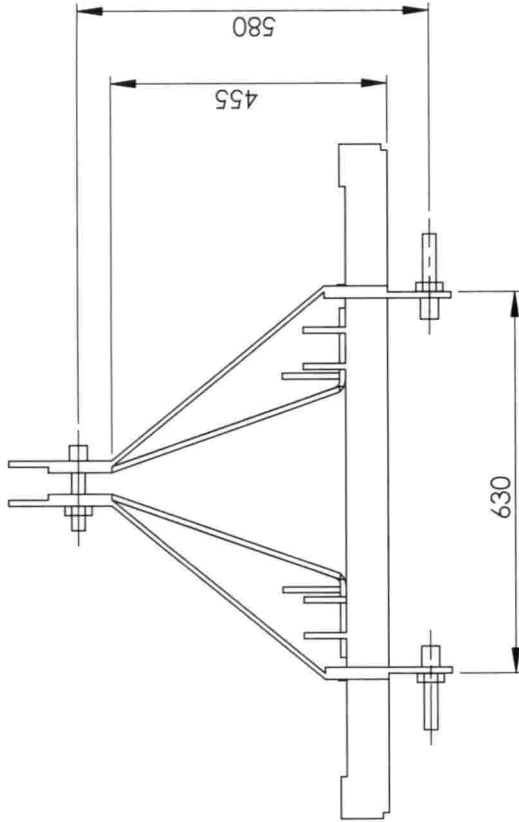
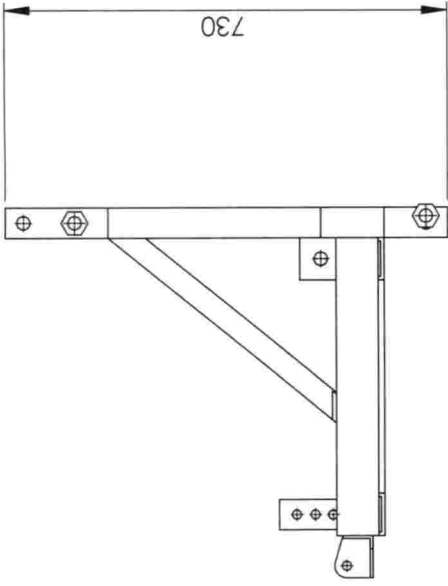

DO NOT SCALE DRAWING  
ALL DIMENSIONS ARE IN mm

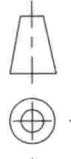

Fig 3.3 TOOL FRAME AND HITCH ASSEMBLY

92

would then be conveyed along the forming boards. Two rectangular forming boards made out of 6 mm thick MS plates were fabricated and arranged in such a manner to converge at the rear to form a trapezoidal shaped bund. Soil gathering boards were fixed on the front to achieve a wider cutting width and to gather more soil on to the bunds. The rear forming case was fixed flush to the forming boards at the rear. The height of the forming boards was fixed at 150 mm for the models BF1 and BF2 while the BF3 model had a forming board height of 300 mm at the front and tapered down to 250 mm at the rear

#### **3.3.5.4 Forming Case**

As per the trials with the initially developed model of the bund strengthening implement, a rear forming case was provided for all the three models developed, as an additional attachment to the rear of the implement. This was made out of 4 mm thick MS sheet. It was a three sided trapezoidal case, with an open bottom, reinforced with MS flats and fitted flush with the rear of the bund former, using nuts and bolts, and had a length of 400 mm. All the elements, including the forming boards and the forming case, acted like a single unit.

Three models of bund strengthening implement – BF1, BF2 and BF3 - were fabricated and their field performance was evaluated. Figures 3.4 to 3.6 show the three models of the developed bund strengthening implement.

### **3.4 DEVELOPMENT OF PROFILE MEASURING INSTRUMENT**

Profiles of ridges or furrows etc. are generally determined by measuring the distance from a reference point to their surface. Pin/stylus type and other contact profilemeters are commonly used for determining the profile and hence cross section of a ridge or furrow, due to their simplicity and ease of operation. Here, the pins make contact with the surface, from a known and fixed reference point, and the distance travelled by the pin is measured, and plotted to provide the profile. However, in the wetland situation, such profilemeters cannot be used, as the pins will penetrate the loose soil surface and accurate profiles will not be

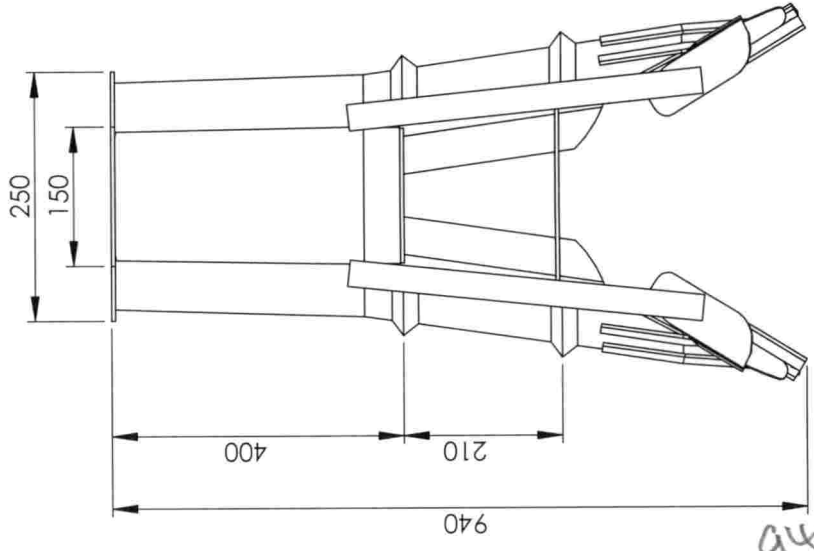
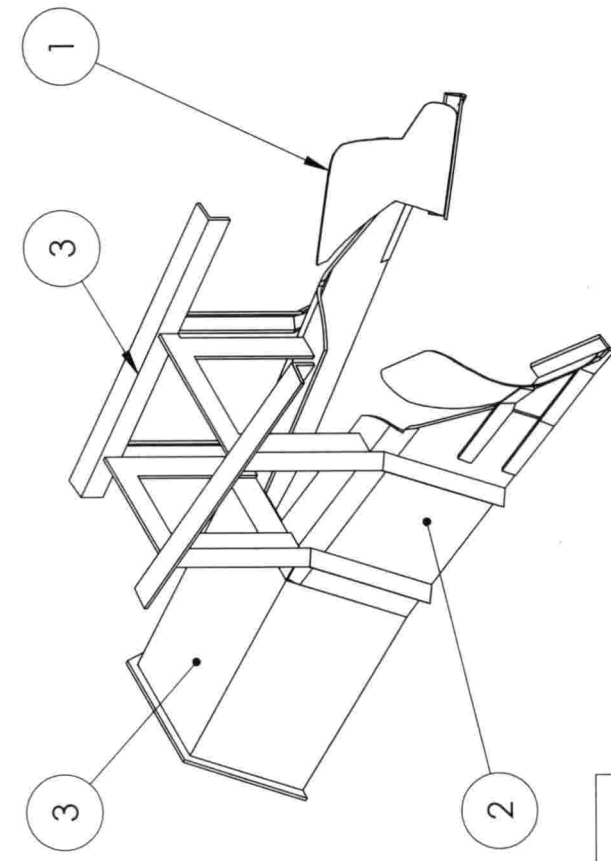
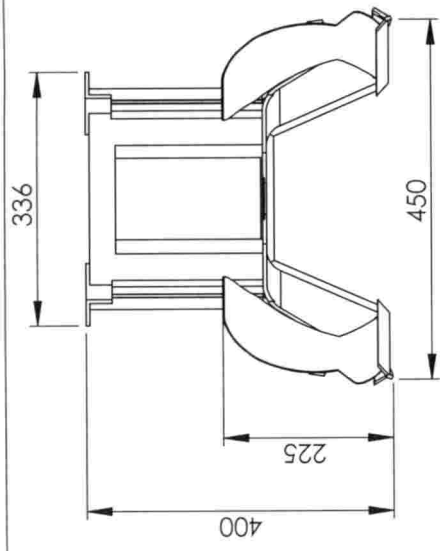
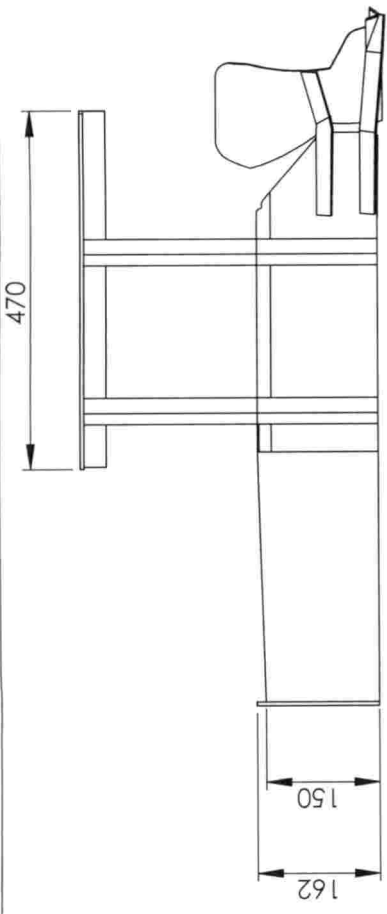

Part No	Description
1	Gathering Board
2	Forming Board
3	Forming Case
4	Frame

DO NOT SCALE DRAWING  
ALL DIMENSIONS ARE IN mm

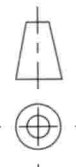
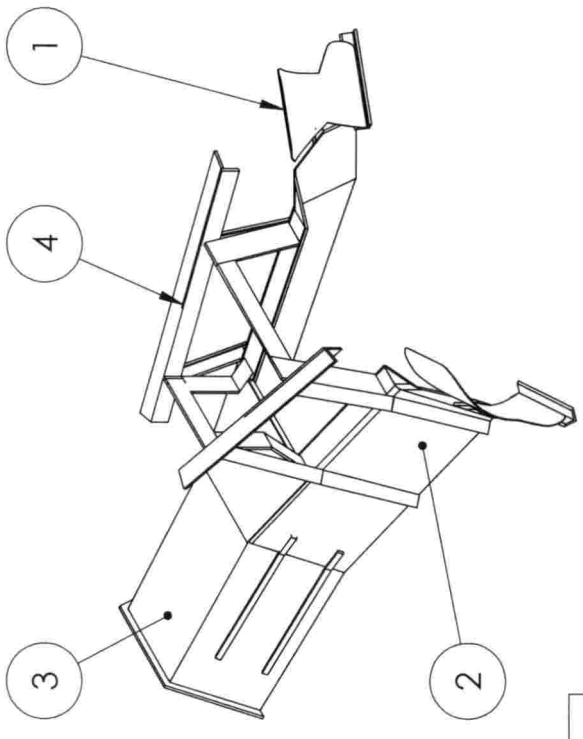
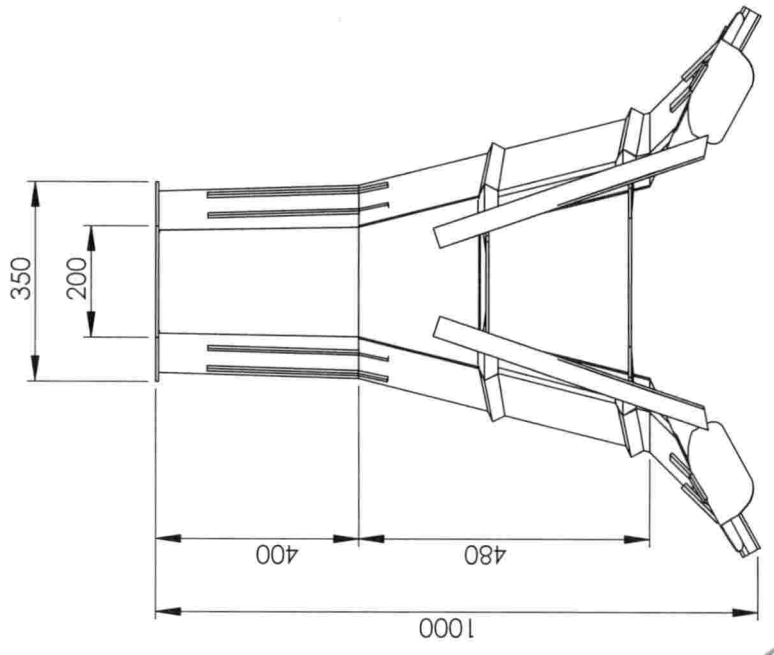
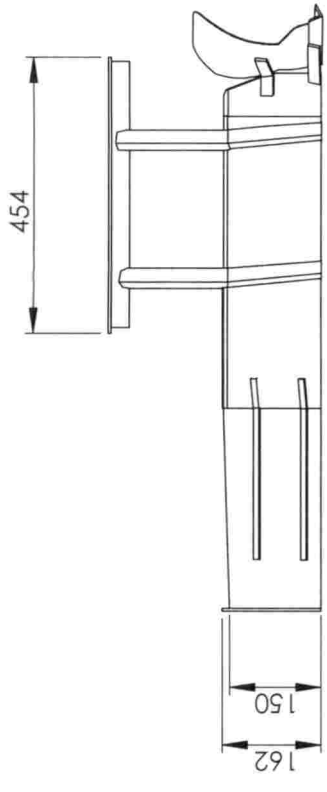
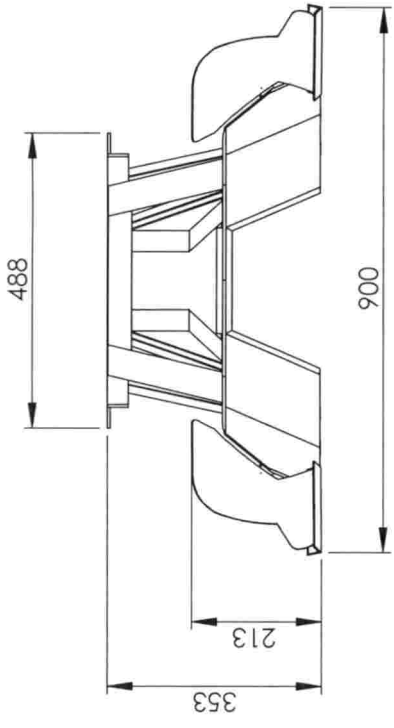

Fig 3.4 BUND STRENGTHENING IMPLEMENT - MODEL BF1

94



Part No	Description
1	Gathering Board
2	Forming Board
3	Forming Case
4	Frame

DO NOT SCALE DRAWING  
ALL DIMENSIONS ARE IN mm

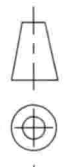
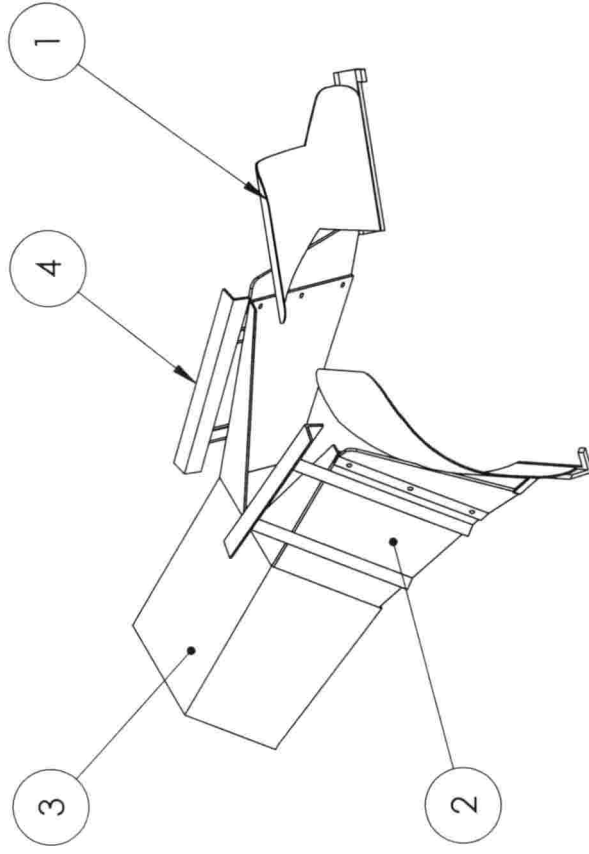
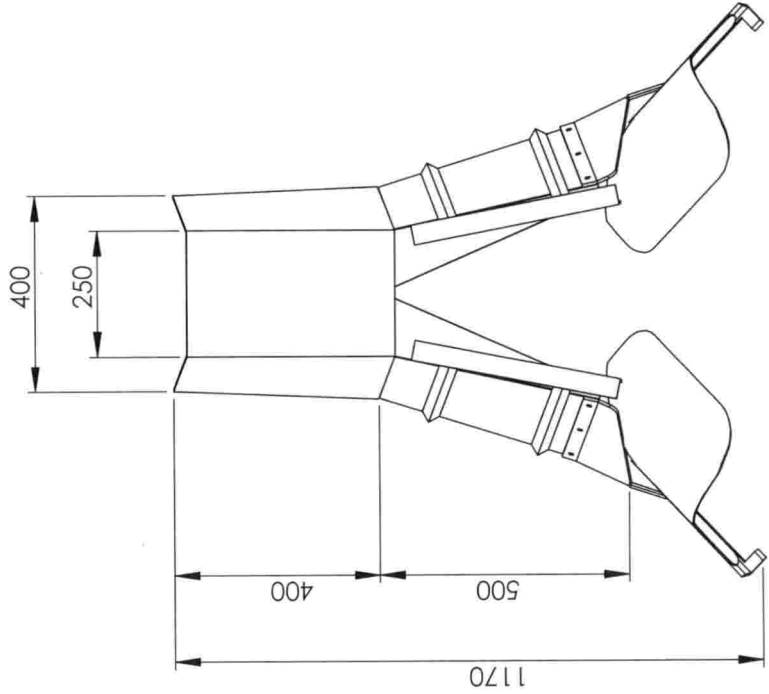
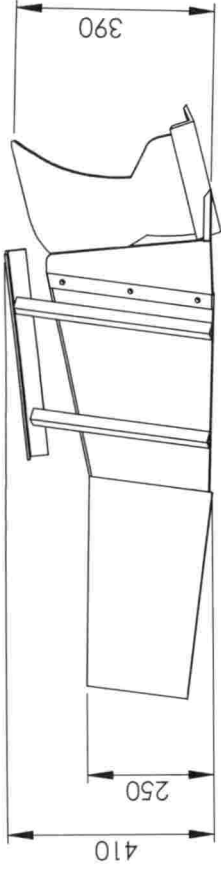
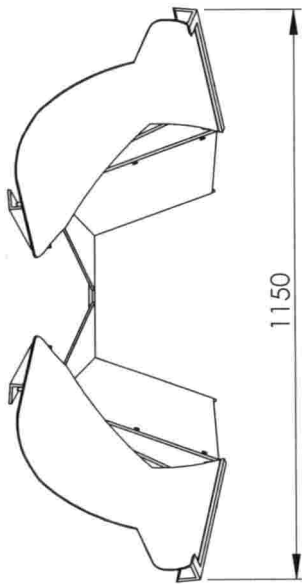

Fig 3.5 BUND STRENGTHENING IMPLEMENT - MODEL BF2

59



Part No	Description
1	Gathering Board
2	Forming Board
3	Forming Case
4	Frame

DO NOT SCALE DRAWING  
ALL DIMENSIONS ARE IN mm



8

Fig 3.6 BUND STRENGTHENING IMPLEMENT - MODEL BF3



measurable. Measurement of dimensions of the formed bunds using pin type profilemeter was very difficult in the wet and submerged field conditions (Plate 3.12).



Plate 3.12 Profile measurement using pin type profilemeter

A non-contact type of profile measuring device only would be effective in such situations. Non-contact type profile measuring devices make use of ultrasonic waves, laser beams, light beams, etc. for measurement of distances. Though many non-contact type devices are available, their high costs prohibit their use in the field of agriculture. Non-contact measurements can be made by using a combination of sensors, microcontroller, and a storing unit. The sensors can be used to sense the distances from a reference point. The microcontroller can be used to control the movements of different parts of the instrument, and to communicate with and control the sensor. The measured data can be stored on a suitable storage platform for retrieval.

As the need for a portable, low cost yet reliable, and non-contact type profile measuring device, suited for measurements in wetland conditions was urgently felt, it was decided to develop a profile measuring instrument on these principles. In order to develop such a device, three aspects were considered: the mechanical construction of the instrument, program development and electrical circuit.

The design was conceptualised to include a frame, on which sensors could traverse to measure distances from the reference frame to the surface of the bund. A motor, powered by a battery, was required to move the sensors, which would record the distances at fixed intervals, over a specified length. A provision for recording the readings from the sensors was also provided. The working of these mechanical parts was to be controlled by a microcontroller, according to the specific program, and necessary electrical circuitry was provided to ensure the supply of required power to the various parts, for the designed operation of the instrument.

### 3.4.1 Prime Mover

The major concerns in selecting the prime mover were that it should be light in weight, portable, produce a high torque and have the ability to start and stop at fixed intervals. A 12 V DC motor (Fig. 3.7) was selected as it could produce movement continuously, and its speed of rotation was easily controllable. These properties are ideal for speed and position control. The speed of rotation of the DC motor was determined by the applied DC voltage and could be varied from a few rpm to thousands of rpm. The output speed of the motor could be decreased by connecting it to suitable gear trains. The torque output was increased at high speed.



Fig.3.7. DC motor (prime mover)

98

From the reviews studied, a 12 V DC motor, capable of producing a torque of 30 kg cm and a speed of 300 rpm was selected for the design. The torque developed during the operation of the motor produced mechanical rotation and hence the motion.

### **3.4.2 Profile Measuring Component**

The profilemeter must measure distances in both the horizontal (X) and vertical (Y) directions. The measuring component should be able to measure distances over the entire width of the bund. The height and width of the bund were limiting factors for fixing the height of the instrument. Taking into account the ranges of widths and heights of bunds/ridges and furrows adopted for cultivation, the height and width of the lateral component was fixed as 1000 mm, to sufficiently cover the entire height and width of the formed bund and for stable placement in the field. The unit was light in weight, and was able to move forward and backward.

The rotary motion of the motor was converted to linear movement by linear actuator, which created a straight line motion despite the circular motion of the electric motor. An electro-mechanical type actuator was selected as it could be automated. The electric motor was mechanically connected to rotate a MS threaded rod, using a gear. A big gear with 60 mm diameter was connected directly to the motor shaft. Small gears with 40 mm diameter were connected to the threaded rod and meshed with the big gear. The rod had a continuous helical thread with a definite pitch. A nut, having corresponding helical threads, was threaded onto the rod. The nut was prevented from rotating freely with the rod, by interlocking it with the non-rotating part of the actuator. Therefore, when the rod was rotated using the motor, the nut was driven along the threads. The main principle was that the threads of the rod acted as a continuous ramp, which allowed a small rotational force to be used over a long distance, to accomplish movement of a large load over a short distance. The direction of motion of the nut

depended on the direction of rotation of the rod. This motion could be converted to usable linear displacement by connecting linkages to the nut.

The length of the linear actuator was 1000 mm (laterally) and the diameter of the thread was 10 mm. The threaded rod was enclosed by a 1000 x 25 x 25 mm square aluminium pipe. The frame, for supporting the instrument, was fabricated using aluminium, due to its light weight which ensured easy portability. The two supporting legs were fixed on 150 x 150 mm rectangular steel plates, for providing stability. Two wooden end caps were placed at the ends of the linear actuator, with ball bearings, for smooth rotation of the threaded rod. A fixed sensor was positioned atop the end cap at one end of the rod, to measure distance in the X- direction. The DC motor, to operate the linear actuator, was connected to the end cap at the other end of the rod. A level indicator (spirit level) was attached to the square pipe, as a provision to level the instrument in the field. A rectangular plate was attached to the vertical bolt, to offer resistance to the fixed sensor. Washers were used between the contact surfaces to allow smooth functioning of the components, in order to minimise wear and tear caused due to the motion (Plate 3.13).

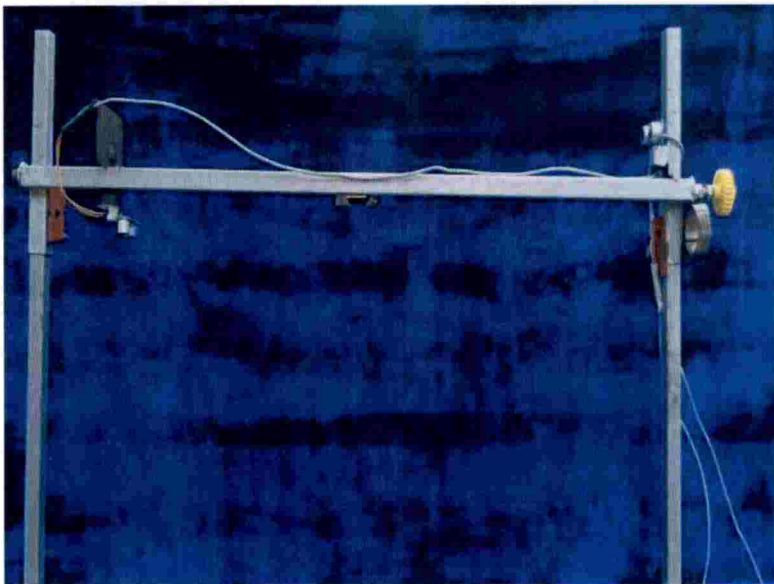

Plate 3.13. Profile measuring component

### 3.4.3 Sensors

Different types of sensors, such as ultrasonic, infrared, and proximity sensors, can be used with Arduino for distance measurement. Based on reviews, it was decided to use ultrasonic sensors, in the instrument, to measure distances, along with the Arduino. These sensors are simple to use, with accuracy levels suitable for the study and affordable. They record the time taken by a sound pulse to travel to a target and return as reflected echo, and can calculate distances up to four meters.

The system consisted of a transmitter circuit and a receiver unit. The HC-SR04 ultrasonic sensor was selected for use in the instrument (Fig. 3.8). This sensor had four pins; Vcc (Voltagein), Trig (Trigger), Echo, and GND (Ground). The Vcc pin required 5 VDC and the GND pin needed to be properly grounded. The Trig pin received a pulse to start ranging and sent out a burst of ultrasound. The Echo pin received the signal and calculated the time between sending a signal and receiving it.



Fig. 3.8HC-SR04 sensor

The speed of sound in air is generally taken as  $340 \text{ m s}^{-1}$  or 29 micro seconds per centimeter. The sound wave, or ping, travels out and back. Hence, to determine the distance of an object from the sensor, half of the distance travelled was taken into account. The distance to an object was calculated as shown below:

$$\text{Speed of sound waves in air} = 340 \text{ m s}^{-1}$$

$$\text{Distance travelled (cm)} = \frac{\text{Time taken } (\mu\text{s})}{29}$$

Time taken by the pulse to reach the target (surface of the bund) is half of the time taken by it to travel from the transmitter and return back to the receiver, as a reflected echo, which is the measured value. Hence the distance to the object was calculated as,

$$\text{Distance to the target (cm)} = \frac{\text{Time taken } (\mu\text{s})}{58}$$

### 3.4.4 SD Card Reader

The SD library permits reading from and writing to the SD card. The communication between the microcontroller and the SD card SPI takes place on digital pins 11, 12 and 13. Another pin was selected additionally to the SD card (Fig. 3.9).



Fig. 3.9 SD card reader

### 3.4.5 Program Development

Reviews indicated the possibility of using Arduino development board, a simple and open source prototype platform, for programming. Arduino is capable of moving the components of the instrument, taking measurements and storing readings.

The Arduino UNO board (Fig. 3.10) was selected for programming, due to its affordable cost, capacity for storing data and a comparatively simple

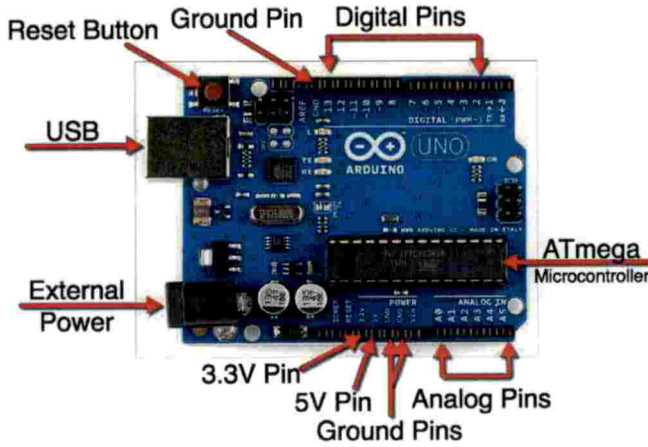

Fig 3.10 Arduino Uno board with pin configuration

programming language. It is a microcontroller board based on the ATmega 328p, having 14 digital input/output pins, six analog inputs, a 16 MHz quartz crystal, a USB connection, a power jack, an ICSP header and a reset button. It was programmed with the Arduino software (IDE) and powered by a USB connection or an external power supply, ranging from 6 to 20 V. Each of the 14 digital pins on the Uno board could be used as input or output, using pin Mode (), digital Write (), and digital Read () functions. They operated at 5 V and provided or received 20 mA as the recommended operating condition. It also had an internal pull-up resistor (disconnected by default) of 20 to 50 k $\Omega$ . The ATmega328 had a memory of 32 kB.

The Arduino project provided the Arduino integrated development environment (IDE), which consisted of a code editor with features such as syntax highlighting, brace matching, cutting-pasting and searching-replacing text, and automatic indenting, and provides simple one-click mechanism to compile and upload programs to an Arduino board. It also had a message area, text console, a tool bar with buttons for common functions and a series of menus. A program written with the IDE for Arduino is called a "sketch". Sketches were saved on the

development computer as files with the file extension .ino. A minimal Arduino C/C++ sketch consists of only two functions:

- *setup()*: This function was called once when a sketch starts after power-up or reset. It was used to initialize variables, input and output pin modes, and other libraries needed in the sketch.
- *loop()*: After *setup()* was called, this function was called repeatedly by a program loop in the main program. It controlled the board until it was powered off or was reset

The profilemeter was designed to measure distances in the X and Y directions. Hence two sensors were required; one fixed sensor to measure the distance in the longitudinal direction (X) and a movable sensor to measure the vertical distance (Y). The readings were subtracted from the datum to obtain the height of the formed bund. The readings were recorded in the memory card.

The program was written to ensure the proper working of the data recording components, reliable working of sensors and their proper positioning of sensors. The sensors took readings at the desired points and recorded these in the memory card. The program also ensured that the sensors changed direction according to the extreme positions of movement on the threaded rod. The program stopped running when the sensors reach the desired stopping position. The flow chart of the working concept of the profile measuring instrument is shown in Fig. 3.11.

### **3.4.6 Electrical Circuit**

The Arduino Uno required a 5 V supply while the DC motor requires 12 V for its working. The components in the electrical circuit were:

- i. A 16-pin, L293D motor driver IC, to control the DC motor and to allow it to provide both clockwise and anti-clockwise drive.
- ii. A breadboard, having many holes into which the circuit components like ICs and resistors were inserted, to build and test circuits easily. The



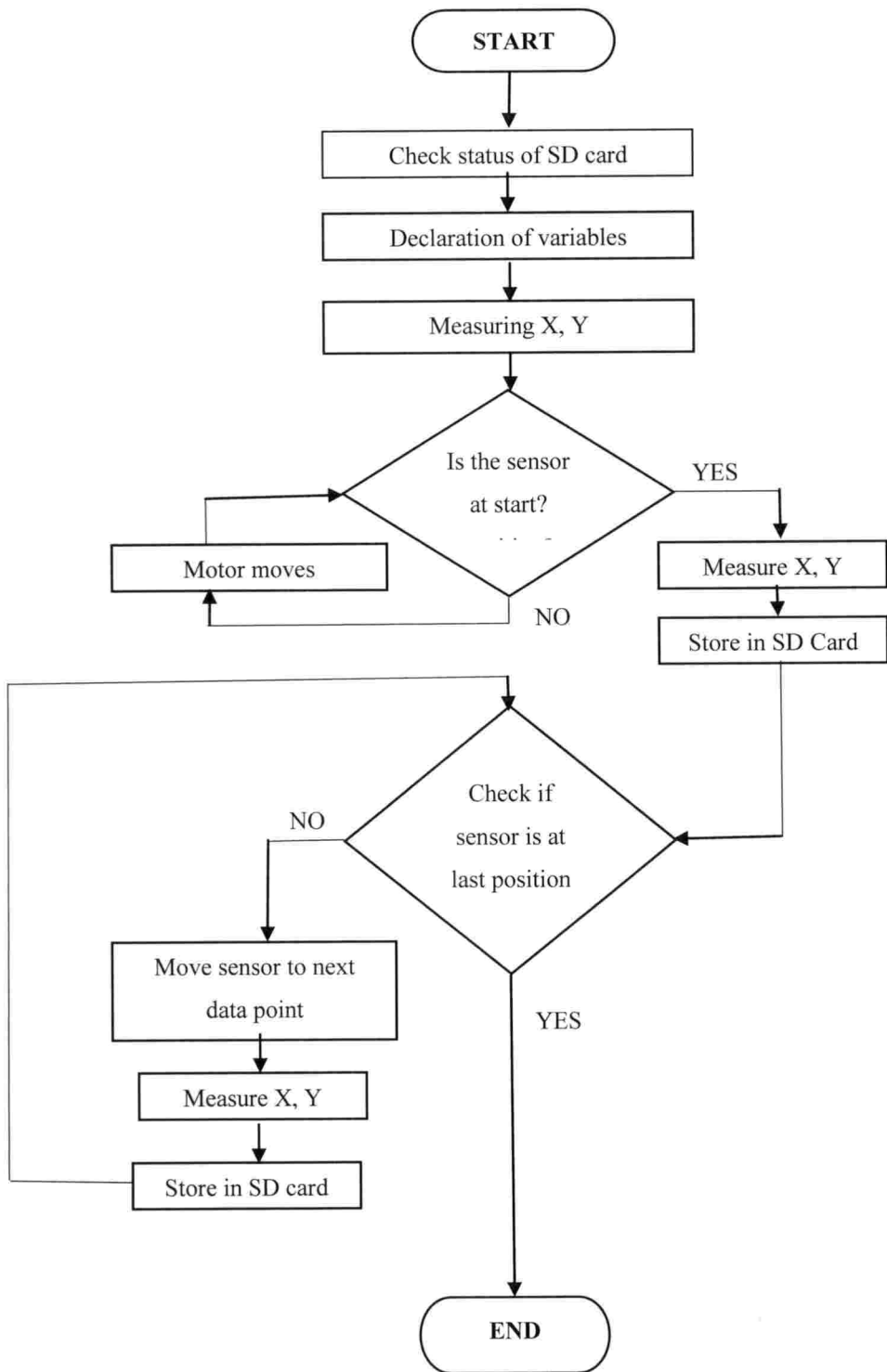

Fig. 3.11 Flow chart of working concept of the profile measuring instrument

- iii. breadboard had metal strips running underneath it that connected the holes on top of the board, to complete circuits.
- iv. Jump wires – short electrical wires with a solid tip at each end, used to interconnect components on a breadboard. These transferred the electrical signals from the breadboard to the input/output pins of the microcontroller.

A 12 V battery was used to power the system. A 16-pin, L293D motor driver IC was provided to control the 12 V DC motor and to allow it to provide both clockwise and anti-clockwise drive. The circuit components were arranged on a breadboard using jump wires, which transferred the electrical signals from the breadboard to the input/output pins of the microcontroller.

### **3.4.7 Testing of the Profile Measuring Instrument**

The developed instrument was 1250 mm long and had a height of 1000 mm. It was tested in a laboratory set up. A rectangular object was made using wood and cardboard. The actual dimensions of this shape were noted, and then the profile of this shape was measured using the developed instrument. Two plots were created in AutoCAD using the actually measured values and the readings obtained from using the profilemeter. The actual readings and readings obtained using the profile measuring instrument was compared using a paired t-test. t-values of the sample data were determined and compared with table t-values. As the obtained t-values were less than the table values, it was concluded that there is no significant difference between the actual measured values and the instrument plotted values and hence the instrument could be used for measuring the profile of the bunds formed by various methods.

The instrument was placed across the bunds to measure the profile. Incremental readings at points 10 mm apart, were measured by the sensor which moved horizontally across the bunds. The sensors could determine the distance moved to and fro, horizontally and vertically by the sound wave. The developed profile measuring instrument was used at the three test locations to plot the profile of the bunds formed (Plate 3.14). The readings recorded by the instrument were

saved in the SD card and these were exported to AutoCAD to directly plot the profiles of the bunds.



Plate 3.14 *In situ* measurement of the bund profile

### 3.5 FIELD TESTING AND PERFORMANCE EVALUATION OF BUND STRENGTHENING IMPLEMENT

The methods and procedures followed for the field testing of the developed bund strengthening units, and the evaluation of their performance at the test locations are described in this section.

The field trials were planned for two locations:

(i) Pullazhi *kolepadavu*, Thrissur *kole*, Thrissur district

(ii) Kolothumpadam *kolepadavu*, Ponnani *kole*, Malappuram district

The trials were started first at Pullazhi *kolepadavu* after the fields were dewatered and ready for bund making and tillage. The selected field had an area of 1.66 ha. The remnants of the bunds from the previous season could be observed and the total length of the bunds in this plot was 570 m. Weeds, though present in the fields, were not observed on the remnant bunds. The trials at the

Kolothumpadam *kolepadavu* were started after the trials at Pullazhi. The selected plot had an area of 3 ha and heavy occurrence of weeds was seen on the remnant bunds. The total length of bunds in this plot was 1048 m. Though the work was planned with taking observational trials in two locations of the *kole* fields - one each at the Thrissur and Ponnani *kole* - once the study was initiated, the necessity of evaluating the implement in non *kole* paddy fields was also felt. Hence the paddy fields at Athalur, Tavanur Panchayath, were also selected for conducting field trials.

### 3.5.1 Power Source

Tractors are not used as power source for tillage operations in the Pullazhi *kolepadavu*, due to the problem of sinkage. Power tillers are common instead. Mini tractors in the power range of 11 kW to 16 kW would be a better substitute to the power tillers as they would reduce the drudgery involved in walking behind the two wheeled power tillers, with the same power availability. Hence, the 11.5 kW KAMCO TeraTrac 4WD tractor (KTT) was used for trials at the Pullazhi *kolepadavu*. However, the initial trials had indicated the limitations of use of this tractor as a power source at the Kolothumpadam *kolepadavu*. The depth of the soft soil layer and the height of the remnant bunds were more at the Kolothumpadam *kolepadavu*, and the ground clearance of the KTT was not suitable for operating it in these field conditions.

The normal practice in this region is the use of tractors having 26 kW or more, as the power source for land preparation. Hence, the 31.32 kW John Deere 5042 tractor (JD 5042) was used for conducting trials in this field. Trials at the Athalur, Tavanur field were carried out using both KTT and 31.32 kW New Holland 3230 tractor (NH 3230). These tractors were operated with cage wheels for proper traction.

### 3.5.2 Experimental Procedure

The three models of the bund strengthening implements – BF1, BF2 and BF3 - were tested at the Pullazhi *kole* lands. The KTT was used as the power source here. At the Ponnani *kole* lands, the BF1 was found unsuitable from initial trials; instead a combination run of BF3 followed by BF2 over the bund formed by BF3 was tried. This trial was named BF4. The JD 5402 tractor was used as the power source here. At Tavanur fields, BF1, BF2, BF3 and BF4 were tried using NH 3230 tractor as power source and BF1 and BF2 were tested with KTT as the power source.

Thus, the trials, at the three identified locations, *viz.*, Pullazhi *kolepadavu*, Thrissur *kole*, Thrissur district, Kolothumpadam *kolepadavu*, Ponnani *kole*, Malappuram district, and Athalur (non *kole*), Tavanur, Malappuram district, were conducted, with the three models of the bund strengthening implement that had been developed in the study.

Observations were taken on the bunds formed and these were compared with the bunds formed manually. The shape, penetration resistance, shear strength, moisture content and bulk density of bunds formed of the bunds formed were recorded, three times, *viz.*, on the day of bund formation (D1), on the third day after bund formation (D3) and on the seventh day after bund formation (D7). Observations were also taken on the performance of the implement in the different fields used for the study. The wheel slip, capacity of the machine, fuel consumption and draft required were measured.

The various observations taken during the performance evaluation were as follows:

### 3.5.3 Shape of Bunds

Bunds are generally trapezoidal in cross section, when formed manually. The bund strengthening implement was designed with the objective of making a bund with trapezoidal cross section. The shape attained by the formed bund is a

parameter for assessment of the performance of the bund strengthening implement. The top width, height and bottom width of the bunds formed during the different trials were recorded on the day of the bund formation. These readings were repeated on the third day and seventh day after the bund formation to assess changes, if any. Similar measurements were also made for bunds formed manually by labourers.

These measurements were taken at all three test locations. The data was analysed using the SPSS 16.0 software. A one factor ANOVA was carried out for the different methods of bund formation and a Duncan's multiple range test was performed to analyse the changes occurring in the bund dimensions over time.

The various soil characteristics such as moisture content, bulk density and strength characteristics like penetration resistance and shear strength were measured on the bunds formed by the different models at different locations, as per procedure specified earlier.

#### **3.5.4 Penetration Resistance (Cone Index) of the Formed Bunds**

The penetration resistance of the bunds formed by the various methods was measured using the procedure explained earlier in Section 3.2.6. The cone index values are an indication of the strength of the bunds. The cone penetrometer was used to measure the soil cone index at different depths down the profile of the bunds formed using the different procedures, starting from 7.5 cm from the top of the bund up to 30.0 cm, in order to assess the strength of the formed bunds. The readings were repeated at the time intervals selected for the study. The values recorded were tabulated and a one factor ANOVA with DMRT was conducted using the SPSS 16.0 software to find out the changes occurring in the strength of the bund down its profile/along its depth. The tests were repeated at all the three test locations.

A bund settles itself over the time progression, though the final settlement is a slow process. An observation of the progressive relative changes in the cone

index would give an indication of the settlement of the bunds. The changes occurring due to loss of moisture in the bunds formed under the different methods were measured based on values of cone index measured at depths starting at the level 7.5 cm from the top of the formed bund, and vertically downwards at consequent depths with an increment of 2.5 cm, till 30 cm. Thus the effects in general were measured at ten vertically downward depths. As the relative changes varied widely, square root transformation was resorted to so as to conform to the basic assumption of ANOVA. OPSTAT software was used for the statistical analysis.

### **3.5.5 Shear Strength of Formed Bunds**

Shear strength is the maximum shear stress that a soil can resist before deformation occurs. The shear strength of the bunds formed by the various methods was measured as per procedure stated in Section 3.2.7. The shear strength values are indicative of the resistance of the formed bunds to shear and hence are an indicator for the compaction or strength of the bund. The values of shear strength were noted at three depths, viz., 0.2 m, 0.4 m and 0.6 m, from the top of the bunds, at all locations.

### **3.5.6 Moisture Content of Formed Bunds**

Moisture content of the soil samples taken from the different bunds formed, at incremental time intervals was determined by the method specified earlier in Section 3.2.2. A one factor ANOVA was carried out for the moisture contents observed from different methods of bund formation and a DMRT was performed to analyse the changes occurring the moisture content over time.

### **3.5.7 Bulk Density of Formed Bunds**

Samples were collected from the different types of bunds formed during the testing, and the wet and dry bulk densities were determined using the standard procedures explained in Section 3.2.4. A one factor ANOVA was carried out for

the values obtained from the different methods of bund formation and DMRT performed to analyse the changes occurring over the period of observation.

The machine parameters that were considered in this study were forward speed, depth of operation and the wheel slip. The KTT was operated in the low speed - first gear and the JD 5042 and the NH 3230 tractors were operated in the low speed - second gear combination to maintain the speed of operation. The depth of operation was controlled at the start of each operation and ranged from 50 mm to 100 mm during the run, depending on the topography of the field and nature of soil. The wheel slip was noted.

### **3.5.8 Speed of Operation**

The speed of operation of the bund strengthening implement – tractor combination was calculated by observing the actual time taken to travel a measured distance and converting it into the units of kilometres per hour. In case of the trial BF4, the time and distance travelled in both passes was noted for calculating the speed and the average speed of the two runs was considered. The KTT was the power source at Pullazhi *kolepadavu*, while at Kolothumpadam *kolepadavu* the JD 5402 was used to operate the implement. At Tavanur fields, both KTT and NH 3230 were used as power sources.

### **3.5.9 Draft**

The draft experienced during the operation was measured using a 5 T load cell dynamometer connected to the front of the tractor to which the implement is attached. An auxiliary tractor was used to pull this tractor, through the load cell dynamometer. The tractor to which the implement is hitched is operated in neutral gear, with the implement in operating position. The pull was recorded in the digital indicator of the dynamometer. The draft was measured as the tractors operated over a fixed length of 20 m (Plate 3.15).





Plate 3.15 Draft measurement in field

### 3.5.10 Fuel Consumption

Fuel consumption at the different operating conditions was measured using the fuel consumption measuring setup, consisting of a 2 L graduated cylinder and necessary tubing to connect to the fuel line and to allow fuel overflow back into the graduated cylinder. The setup is illustrated in Plate 3.16. The graduated cylinder was filled to its full capacity before and after operation. The fuel consumed during the operation of the tractor – implement combination and the time of operation were noted to arrive at the fuel consumption in  $L h^{-1}$  and  $L m^{-1}$  bund formed.



Plate 3.16 Setup for measurement of fuel consumption

### 3.5.11 Capacity

Capacity is defined as the actual length of bunds formed during actual time of operation of the implement. The tractor-implement combination was operated over a specified area to form the bunds and the actual time taken for the operation, including time lost in stopping, turning etc. was noted. The capacity of the implement is defined here as the length of bund formed in unit time and is expressed in metres per hour of operation.

$$C = \frac{L}{t},$$

where,

C = capacity of the implement, m h<sup>-1</sup>

L = actual length of bund formed, m

t = actual time taken to form the bund, h

The observations for capacity of the implement were recorded during trials with all types of the bund strengthening implement and at all test sites.

The capacity of manual bund formation was also calculated. It was seen that usually one male labour worked for a day of six hours in the paddy fields for forming and strengthening of bunds. The labourer could form an average of about 375 m to 450 m of bund in this time, depending on his expertise. Thus, the manual labourer was able to form only about 62.5 m to 75 m of bund per hour on an average.

### 3.5.12 Wheel Slip

The distance travelled by the tractor - implement combination in a given number of rotations of the drive wheel decreases when the wheel slips. The number of rotations of the tractor drive wheel taken to cover a fixed distance marked out in the field under load and no load condition were recorded. A visible

mark was made on the drive wheel periphery, at a point, so that the rotations could be counted. The wheel slip was calculated as follows:

$$\text{Wheel slip (\%)} = \frac{(N - N_0)}{N} \times 100$$

where,

$N_0$  = number of rotations of the drive wheel at no load condition

$N$  = number of rotations of the drive wheel at load condition

The readings for wheel slip were noted in all the test runs and at all the test sites.

### **3.5.13 Cost of Operation**

Generally, cost of operation of an implement is expressed in terms of cost per unit time of operation or in terms of cost per unit area. As lengthwise bunds are the resultant of the operation of different bund strengthening implements, the cost of operation of such implements can be expressed in terms of cost per unit length of bund formed.

The cost of operation was calculated for all the different types of bund strengthening implements on the basis of both per hour of operation and per unit length of bund formed. IS 9164-1979 (Reaffirmed 2002) was used as the reference for calculating the cost.

### **3.5.14 Deformation and Stress Analysis**

As the model BF3 was expected to be subjected to the highest stress during operation on account of its bigger size and more volume of soil handled, a deformation and stress analysis was also carried out on this model using the ANSYS 16.0 software to determine the safety of the implement.

## ***Results & Discussion***

## CHAPTER IV

### RESULTS AND DISCUSSION

This chapter describes the results of the initial experiments conducted for the development of bund strengthening implement for paddy wetlands, the soil properties of the selected research sites, the development of the bund strengthening implement and necessary instrumentation, and performance evaluation of the developed implement.

#### 4.1. CONCEPT AND PRELIMINARY STUDIES

The study was undertaken with the objective of developing a low cost bund strengthening implement for paddy wetlands, in order to provide farmers with an economical alternative for the process of manual bund making in the *kole* lands. Preliminary studies were carried out as described in Sections 3.1.1 and 3.1.2 and the results of these studies are presented below.

##### **4.1.1 Study-I: Assessment of Suitability of Power Tiller Operated *Kaipad* Bund Former**

The power tiller operated *kaipad* bund former was tested in Pullazhi *kolepadavu* as described in Section 3.1.1. Fifty metres of bund was formed using the implement. The observations from the study are given below:

- a) the bund former cut and gathered the soil from the field at the side of the existing bund from depths upto 20 cm and more
- b) the cut soil was deposited unevenly over the existing bund
- c) clogging of the bund former blades was also severe
- d) the draft experienced by the power tiller was very high and the power tiller could not develop sufficient traction
- e) the tiller-bund former combination experienced toppling or overturning, as increased weight acted on the rear of the implement. Even the highly

skilled and experienced operator could not manage the power tiller-  
implement combination.

- f) neither a satisfactory cross section nor a continuous stretch of bund could be achieved

The bund formed using the power tiller operated *kaipad* bund former is shown in Plate. 4.1.

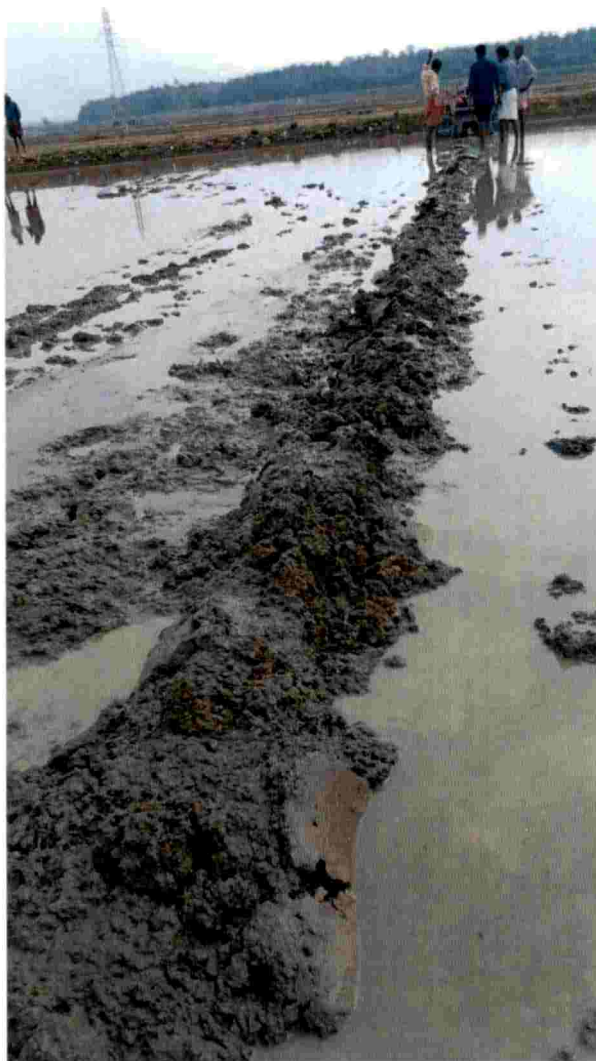

Plate 4.1 Bund formed using power tiller operated *kaipad* bund former

#### 4.1.2 Study-II: Assessment of Suitability of Mini Tractor Operated KAU Bed Former

The suitability of the KAU bed former operated by the KAMCO TeraTrac mini tractor was assessed at the Pullazhi *kolepadavu*, as explained in section 3.1.2. The bund formed after operation is as shown in Plate 4.2. The following observations could be made after this study.

- a) A bund, approximately trapezoidal in cross section and with a height ranging from 10 to 20 cm was formed.
- b) The action of the bed former in gathering soil inwards on the bund showed promise, though the shape formed was not a perfect trapezoidal cross section.
- c) The mini tractor, which was operated using the pneumatic tyres, did not develop sufficient traction.

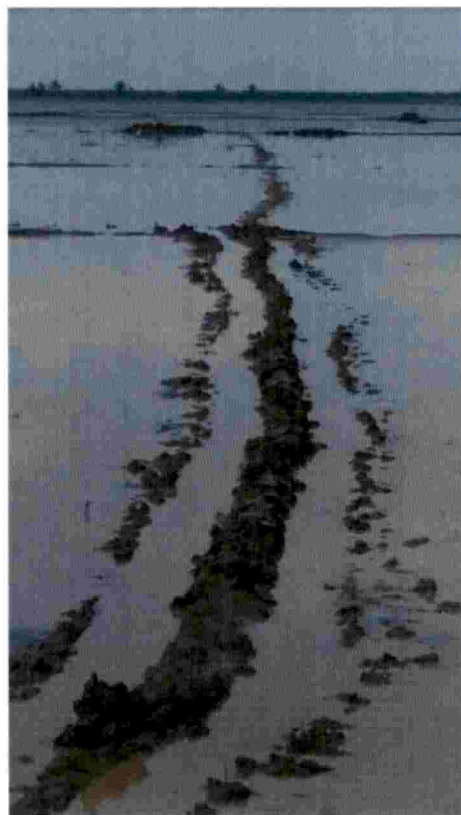

Plate 4.2. Bund formed by KAU bed former using KAMCO TeraTrac mini tractor

The following inferences were drawn from these two studies:

1. the power tiller operated *kaipad* bund former was not suitable for formation of bunds in the field conditions of the *kole* lands
2. traction developed by the power tiller was not adequate for the operation of cutting, trimming, forming or shaping, and strengthening the existing bunds
3. the mini tractor with its four wheel drive was a promising power source as it could be operated in a straight line and could be controlled and manoeuvred easily; however the pneumatic wheels should be replaced by cage wheels
4. the bund strengthening implement could be designed on the lines of the former board type bund former, as such implements could cut the excess soil from the flattened sides of the bund, heap it on top and form it into a trapezoid cross section

#### **4.1.3 Preliminary Soil Studies**

As explained in section 3.1.3, the properties of the soil samples collected from the Pullazhi *kolepadavu*, as part of the preliminary studies, were analysed and the data is presented in Appendix I.

### **4.2 DETERMINATION OF SOIL PROPERTIES OF TEST LOCATIONS**

#### **4.2.1 Selection of Research Locations**

Three research locations – Pullazhi *kolepadavu* in Thrissur *kole* lands, Kolothumpadam *kolepadavu* in Ponnani *kole* lands and Athalur, Tavanur (non *kole*) - were identified to carry out the field testing and performance evaluation of the developed models of bund strengthening implement, as explained in Section 3.2.1.

The soil properties of the three research sites were determined. The results of these experiments are presented below.



#### 4.2.2 Moisture Content

The moisture content was determined as per the procedure elaborated in Section 3.2.2 and the readings are presented in Table 4.1. The readings varied from 52.63 to 57.85 per cent in Pullazhi, 65.38 to 66.67 per cent in Ponnani and 45.33 to 48.10 per cent at Tavanur.

#### 4.2.3 Soil Texture

The particle size analysis was carried out as described in section 3.2.3 and the sand, silt and clay fractions were separated out. These were plotted on the USDA soil texture triangle to obtain the soil types and the results are shown in Table 4.1. From the USDA textural triangle plots, it was seen that soils in Pullazhi *kolepadavu* were silty clay in nature, with sand fractions in the range 5.74 to 6.77 per cent, silt ranging from 45.52 to 48.03 per cent and clay from 46.25 to 47.76 per cent. The soils of Kolothumpadam *kolepadavu* were also silty clays, with the sand, silt and clay fractions ranging between 2.77 to 4.05 per cent, 41.68 to 44.88 per cent, and 51.78 to 55.55 per cent respectively. The analysis of the soils at Athalur, Tavanur showed them to be sandy loam, with the sand, silt and clay proportions lying between 60.77 to 63.99 per cent, 24.29 to 25.44 per cent and 11.51 to 13.79 per cent respectively.

#### 4.2.4 Bulk Density

The wet and dry bulk densities were calculated as explained in section 3.2.4 and is depicted in Table 4.1. The values of wet bulk density were observed to vary from 1.44 to 1.55 g cm<sup>-3</sup> in Pullazhi *kolepadavu*, 1.83 to 1.86 g cm<sup>-3</sup> in Kolothumpadam *kolepadavu*, and 1.70 to 1.85 g cm<sup>-3</sup> in Tavanur. The dry bulk density values were seen to range between 0.91 g cm<sup>-3</sup> to 1.01 g cm<sup>-3</sup> in Pullazhi, 1.10 g cm<sup>-3</sup> to 1.12 g cm<sup>-3</sup> in Ponnani, and 1.15 g cm<sup>-3</sup> to 1.27 g cm<sup>-3</sup> in Tavanur.

#### 4.2.5 Soil Consistency Limits

The soil consistency limits or the Atterberg limits of a soil *viz.*, liquid limit, plastic limit and shrinkage limit, and the plasticity index of the soil were

Table 4.1 Properties of the field soils at the test locations

Sl. No.	Location	Moisture content (per cent)±SE	Wet bulk density (g cm <sup>-3</sup> ) ± SE	Dry bulk density (g cm <sup>-3</sup> )± SE	Particle size distribution (per cent)± SE			Soil type	Atterberg limits (per cent)± SE			Plasticity Index± SE
					Sand	Silt	Clay		Liquid limit	Plastic limit	Shrinkage limit	
1	PU1	54.412±1.30	1.482±0.07	0.960±0.04	5.73±0.69	48.03±0.71	46.23±1.39	Silty clay	60.79±1.03	43.02±0.86	15.37±1.26	17.77±1.44
2	PU2	52.632±0.76	1.546±0.01	1.013±0.003	6.77±0.16	45.53±0.98	47.70±0.99	Silty clay	60.60±1.78	49.58±1.18	11.31±0.60	11.02±2.21
3	PU3	57.851±0.35	1.443±0.03	0.914±0.12	6.72±0.44	45.52±0.26	47.76±0.20	Silty clay	61.38±1.08	41.19±1.01	9.88±0.62	20.19±1.85
4	PO1	66.667±0.76	1.862±0.05	1.117±0.03	2.77±0.18	41.68±0.97	55.55±0.80	Silty clay	69.52±1.38	45.00±1.12	8.56±0.58	24.52±0.44
5	PO2	65.385±0.75	1.832±0.04	1.108±0.03	4.05±0.14	42.22±0.71	53.73±0.59	Silty clay	67.08±1.12	41.78±2.01	11.88±0.91	25.30±1.83
6	PO3	65.462±0.72	1.845±0.02	1.115±0.01	3.34±0.44	44.88±0.75	51.78±0.33	Silty clay	69.21±0.91	46.48±2.26	9.38±0.19	22.73±2.00
7	TVR1	48.101±0.35	1.703±0.02	1.150±0.04	60.77±0.75	25.44±0.47	13.79±0.30	Sandy loam	34.44±2.97	17.34±1.31	19.06±2.19	17.10±3.44
8	TVR2	47.573±0.26	1.829±0.01	1.239±0.01	62.41±2.47	24.29±1.22	13.30±1.28	Sandy loam	32.15±2.58	18.81±1.03	15.80±0.84	13.34±2.27
9	TVR3	45.333±0.50	1.851±0.02	1.274±0.01	63.99±1.82	24.50±1.72	11.51±0.66	Sandy loam	29.17±1.00	20.10±1.01	29.59±0.75	9.07±0.31

PU1, PU2, PU3 – Sites of sample collection at Pullazhi kolepadavu, Thrissur kole  
 PO1, PO2, PO3 – Sites of sample collection at Kolothupadam kolepadavu, Ponnani kole  
 TVR1, TVR2, TVR3 – Sites of sample collection at Athalur, Tavanur

122

determined as per procedures described in section 3.2.5 and are presented in Table 4.1. The values of the liquid limit were observed to vary from 60.60 to 61.38 per cent at Pullazhi, 69.21 to 69.52 per cent at Ponnani, and 29.17 to 34.44 per cent at Tavanur. The values for plastic limit were found to range between 41.19 to 49.58 per cent at Pullazhi, 41.78 to 46.48 per cent at Ponnani and 17.34 to 20.10 per cent at Tavanur. The shrinkage limit values were between 9.88 and 15.37 per cent in Pullazhi, 8.56 and 11.88 per cent in Ponnani and 15.80 and 29.59 per cent in Tavanur.

The plasticity index (the difference between the liquid and the plastic limits) was also determined and presented in the Table 4.1. The ranges observed were 11.02 to 20.19 at Pullazhi, 22.73 to 25.30 at Ponnani and 9.07 to 17.10 at Tavanur.

#### 4.2.6 Penetration Resistance (Cone Index)

The measurement of cone index of the field soils, at all the three test locations were carried out as per procedure elaborated in section 3.2.6. The mean readings observed are presented in Table 4.2. The values are appended in Appendix II.

Table 4.2 Changes in cone index at increasing depths at the test locations

Sl. No.	Depth (cm)	Mean cone index (kg cm <sup>-2</sup> ) ± SE		
		Pullazhi <i>kolepadavu</i> (Thrissur <i>kole</i> )	Kolothumpadam <i>kolepadavu</i> (Ponnani <i>kole</i> )	Tavanur (non – <i>kole</i> )
1	7.50	1.45 ± 0.05	0.20± 0.02	1.58 ± 0.00
2	10.00	1.78 ± 0.14	0.28± 0.03	2.05 ± 0.04
3	12.50	2.01 ± 0.15	0.31± 0.04	2.62 ± 0.05
4	15.00	3.16 ± 0.51	0.41± 0.04	3.22 ± 0.09
5	17.50	4.00 ± 0.50	0.55± 0.05	4.02 ± 0.15
6	20.00	5.07 ± 0.42	1.00± 0.06	5.42 ± 0.33
7	22.50	5.07 ± 0.44	1.02± 0.07	7.30 ± 0.68
8	25.00	5.61 ± 0.49	1.86± 0.09	9.00 ± 0.57
9	27.50	5.50 ± 0.55	4.20± 0.08	10.68 ± 0.66
10	30.00	5.90 ± 0.67	6.46± 0.21	11.43 ± 0.28

The values of cone index increased with depth and averaged from 1.45 to 5.90 kg cm<sup>-2</sup> in Pullazhi *kolepadavu*, 0.20 to 6.46 kg cm<sup>-2</sup> in Kolothumpadam *kolepadavu* and 1.58 to 11.43 kg cm<sup>-2</sup> in Tavanur, over the depths ranging from 75 mm to 300 mm, at increments of 25 mm. This was in consonance with observations made in many earlier studies.

Penetration resistance of the soil or the cone index value is a resultant of many soil properties like the soil texture, depth of measurement, moisture content. Sand and silt fractions tend to increase the cone index, while cone index decreased with clay fractions. Increase in moisture tends to decrease the cone index.

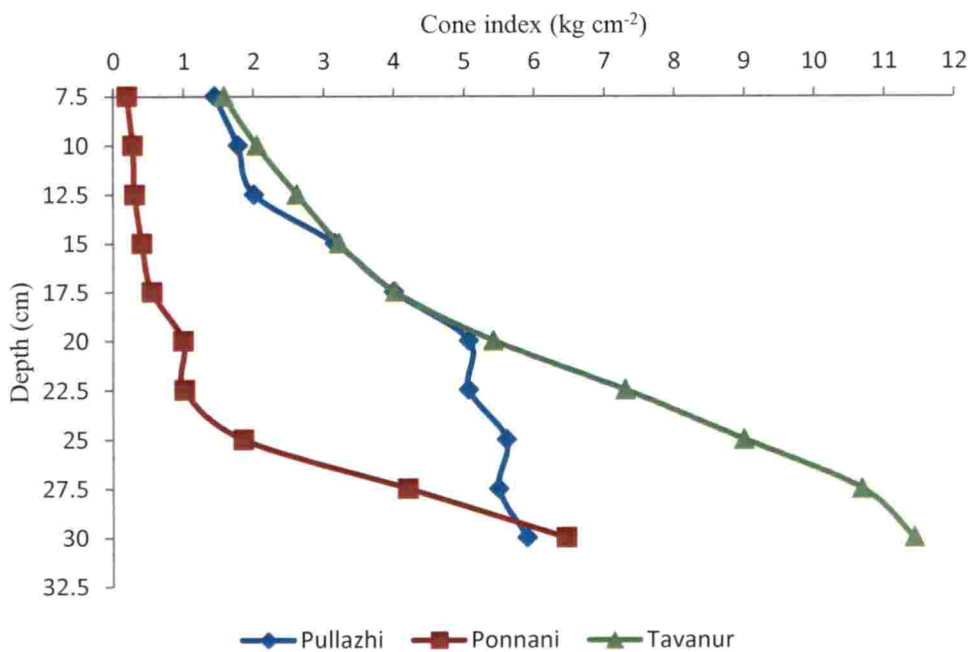

Fig. 4.1 Variation in cone index (kg cm<sup>-2</sup>) in field soil at the test locations

The change in the values of cone index with depth of observation is plotted in Fig. 4.1.

The sand content in the soils at Tavanur was very high compared to the other two locations and this causes the observed increase in the cone index observations. The moisture content is also lower here, which contributes to increased friction and thus an increased cone index. In soils at Kolothumpadam

124

*kolepadavu* the clay content is higher. The soil exhibits higher moisture content also. The combination of these parameters led to a low value of cone index at all depths of observation here. The soils at Pullazhi *kolepadavu* have a smaller clay fraction in comparison to the Kolothumpadam *kolepadavu* soils, and the moisture content readings here are also comparatively low. This may be the reason for the increased readings of cone index, in comparison to the silty clays of Kolothumpadam *kolepadavu*. These observations are in tandem with Kumar *et al.*, 2012.

#### 4.2.7 Shear Strength

The shear strength of soil at the three research locations were determined as per the procedure explained in section 3.2.7. The mean shear strength obtained is depicted in Table 4.3. The values are appended in Appendix II.

Table 4.3 Shear strength measured in the fields at research locations

Sl. No.	Depth (m)	Mean shear strength (kPa) ± SE		
		Pullazhi <i>kolepadavu</i> (Thrissur <i>kole</i> )	Kolothumpadam <i>kolepadavu</i> (Ponnani <i>kole</i> )	Tavanur (non – <i>kole</i> )
1	0.2	23.44 ± 1.23	16.5 ± 0.71	26.92 ± 0.71
2	0.4	54.70 ± 1.23	74.67 ± 1.42	48.62 ± 0.71
3	0.6	13.89 ± 0.71	88.57 ± 2.46	54.70 ± 2.46

The shear strength values are seen to increase with depth of observation in both the Ponnani *kole* and fields at Tavanur, while it is seen to decrease after the depth of 0.4 m at Pullazhi *kole*. Increasing sand fraction increased the shear strength of soils while increased clay fractions caused a decrease in it. Shear strength also increases with increase in moisture content (Manuwa and Olaiya, 2012; Rathnam *et al.*, 2015; Islam *et al.*, 2016). Increase in bulk density also causes increase in shear strength (Dhawale and Harle, 2017). Hence, many soil properties affect the shear strength of soils. Tillage generally brings about a decrease in the soil strength and bulk density as reported in Kumar *et al.* (2012). The decrease in shear strength of *kole* soils in Pullazhi *kolepadavu*, after the depth

125

of 0.40 m indicate the presence of a hard pan at that depth, below which the resistance of soil to shear decreases. This also indicates the difficulty in operating heavy machinery in this area, especially when the water content is high, as during tillage. The greater percentage of clay fraction in the soil probably increases the cohesion in the deeper layers of soil at the Kolothumpadam *kolepadavu*. Heavier machinery are being used in the area. These may be the cause of increase in shear strength of soil that is observed here. The combined effect of the various physical and engineering properties of the soil typical to the region also probably contributed to this effect.

Figure 4.2 represents the changes in shear strength in the soils at the test locations.

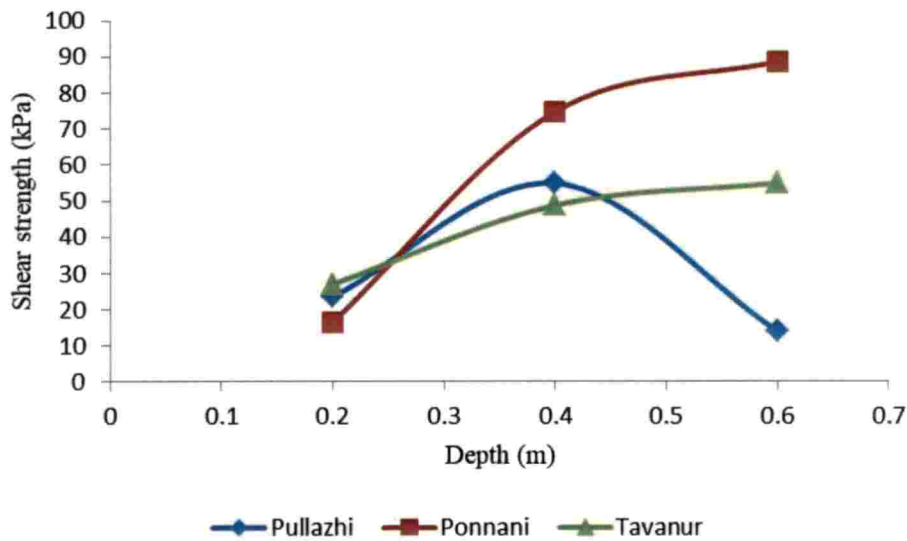

Fig. 4.2. Changes in shear strength over depth in field soils at the test locations

#### 4.2.8 Organic Matter

The organic carbon and organic matter content was assessed as per the procedure in section 3.2.8. The mean values are presented in Table 4.4 and the values are presented in Appendix II.

128

Table 4.4 Organic carbon and organic matter content of soils at test locations

Sl. No.	Location	Organic carbon (%)	Organic matter (%)	Remarks
1	Pullazhi <i>kolepadavu</i> (Thrissur <i>kole</i> )	3.44 ± 0.27	5.92 ± 0.46	High
2	Kolothumpadam <i>kolepadavu</i> (Ponnani <i>kole</i> )	3.55 ± 0.10	6.11 ± 0.17	High
3	Tavanur (non- <i>kole</i> )	1.16 ± 0.33	1.99 ± 0.57	Medium

The Pullazhi and Ponnani *kole* soils showed a high organic matter content of 5.42 to 6.33 per cent, and 5.95 to 6.28 per cent, respectively, while the organic matter content in the Tavanur soils was found to be at medium levels.

#### 4.3 DEVELOPMENT OF THE TRACTOR OPERATED BUND STRENGTHENING IMPLEMENT FOR PADDY WETLANDS

##### 4.3.1 Development of the Bund Strengthening Implement – Initial Design Considerations

The front cutting width of the bund strengthening implement was fixed at 0.35 m in the initial design by considering the dimensions of the formed bund as 0.15 m x 0.25 m x 0.15 m, matching with farmers’ practice and depth of cut as 0.06 m, as explained in Section 3.3.1.

##### 4.3.2. Development of the Bund Strengthening Implement – Stage I

The first model of the bund strengthening implement was developed with a tool frame and hitch assembly, implement frame, forming boards and rear forming plate/ press plate. The following observations were made after operating the implement for 50 m in the trial location.

- a) Though a bund was formed with trapezoidal cross section, the formed bunds were not sufficiently smoothed.
- b) It was seen that the rear press plate could not effectively smoothen the top of the bunds.

Plate 4.3 shows the bund formed by the first model of the bund strengthening implement.



Plate 4.3. Bund formed using the first model

#### **4.3.3. Development of the Bund Strengthening Implement – Stage II**

The second model of the bund strengthening implement was developed as explained in Section 3.3.3. The implement was operated in field and bunds were formed, using the implement attached with the three forming cases. From visual evaluation, it was noticed that the bunds formed using all the three forming cases attained a smoother outer surface when compared to the earlier trials. The resultant bund is shown in Plate 4.4. However, the forming cases having lengths



of 400 mm and 600 mm gave a better result, in terms of the shape attained and retained by the bund, as compared to the 200 mm long forming case. No difference was observed among the bunds formed using the forming cases with lengths 400 mm and 600 mm. Hence the length of 400 mm was the dimension chosen for the rear forming case of the bund strengthening implement.



Plate 4.4. Bund formed with forming case attached to bund strengthening implement

The values obtained for bulk density of field soil, ranged from  $1.44 \text{ g cm}^{-3}$  to  $1.55 \text{ g cm}^{-3}$ , indicating that there was a wide variability in the soil properties even within a *padashekharam*. The bulk density of the bunds formed was seen to increase upto  $2.00 \text{ g cm}^{-3}$ . The initial model, with a 400 mm long forming case, gave satisfactory results when tested at Pullazhi *kolepadavu*.

#### 4.3.4 Development of the Bund Strengthening Implement – Stage III

The field tests conducted using the developed model of the bund strengthening implement at Kolothumpadam *kolepadavu* in Ponnani *kole* lands, as detailed in Section 3.3.4, showed that:

- bunds with satisfactory cross section could be achieved in places where the water level was low (Plate 4.5).



Plate 4.5 Bund formation at Ponnani *kole* fields with low water levels

- the KAMCO TeraTrac mini tractor was not suited to be used as a power source in the *kole* fields at the location. The depth of soft and loose soil here was from 300 mm to 600 mm and the tractor could not develop the required traction to move in such soils. The tractor cage wheels were clogged with mud and sinkage occurred (Plate 4.6). Moreover, tractors with higher horsepower were in use in these fields. Hence, a tractor of higher horsepower was selected for use in the fields at Ponnani *kole* lands.
- the water level in the fields was higher than that observed in the fields at Pullazhi (upto 350 mm). Though bunds could be formed in these areas, they were completely submerged.
- the manual bunds prevalent at the site were of bigger dimensions, with an average top width of 250 mm, bottom width of 400 mm and height of 250 mm. The model tested here did not suit the farmers' practice.



Plate 4.6 Sinking of KAMCO TeraTrac tractor at Ponnani *kole*

Hence, a bund strengthening implement of larger dimensions, to suit the conditions of the Ponnani *kole* fields was to be developed. The bulk density values of the field at Ponnani ranged from  $1.83 \text{ g cm}^{-3}$  to  $1.86 \text{ g cm}^{-3}$  and had a higher percentage of clay content, as compared to soils at Pullazhi *kole* lands.

#### **4.3.5 Development of the Bund Strengthening Implement – Stage IV**

As explained in Section 3.3.5, after the initial trials and tests in the field, three models of tractor drawn bund strengthening implement (BF1, BF2 and BF3) were fabricated. The main parts of the implement were the tool frame and hitch assembly, implement frame, modified forming boards and forming case.

##### **4.3.5.1 Tool Frame and Hitch Assembly**

A rectangular tool frame having dimensions of 1150 x 500 mm was fabricated using 71 mm MS square and 65 x 65 x 8 mm MS angle bar. A standard three point linkage hitch bracket and the implement were attached to this frame and the assembly was hitched to the tractor, for operation. The frame weighed 63.65 kg.

#### **4.3.5.2 Implement Frame**

The implement frame consisted of two risers each, using 25 x 25 x 3 mm MS angle, welded on to the outer surface of the forming boards. These were joined on the top to two horizontal 35 x 35 x 3 mm MS angle. The forming case, joined at the rear of the forming boards, held the implement as a single unit. This frame was screwed on to the 1000 mm long, 150 mm wide, and 8 mm thick MS plates on the front and rear end, and then attached to the tool frame. Slots were provided in the MS plates, so that the position of the implement frame could be adjusted on it, as per the dimensions of the model being attached.

#### **4.3.5.3 Modified Forming Boards**

Two rectangular forming boards were made out of 6 mm thick MS plates. They converged at the rear to form a trapezoidal shaped bund. Soil gathering boards were fixed on the front to achieve a wider cutting width. Forming boards of BF1 and BF2 had a height of 150 mm and BF3 model had a forming board height of 300 mm at the front and tapered down to 250 mm at the rear.

#### **4.3.5.4 Forming Case**

A forming case, having a trapezoidal cross section with the bottom open was made of 4 mm thick MS sheet and reinforced using 12 x 5 mm MS flats. This was fixed flush to the forming boards at the rear. The length of the forming case was 400 mm. All the elements, including the forming boards and the forming case, acted like a single unit.

Three models of bund strengthening implement were fabricated, based on observations from trials conducted at Thrissur and Ponnani *kole* lands, with the major dimensions as given in Table 4.5.

Table 4.5 Major dimensions of different models of bund strengthening implements

Sl. No.	Dimension	Model		
		BF1	BF2	BF3
1	Cutting width (mm)	450	900	1150
2	Rear height (mm)	150	150	250
3	Top width – rear (mm)	150	200	250
4	Bottom width – rear (mm)	250	350	400
5	Weight (kg)	18.55	22.15	39.60

The three models that have been developed are shown in Plates 4.7 to 4.9.



Plate 4.7 Bund strengthening implement – Model BF1



Plate 4.8 Bund strengthening implement – Model BF2



Plate 4.9 (a) Bund strengthening implement – Model BF3 – front view



Plate 4.9 (b) Bund strengthening implement – Model BF3 – side view

#### 4.4 DEVELOPMENT OF PROFILE MEASURING INSTRUMENT

A low cost, portable, non-contact type profile measuring instrument was developed for measuring the profile of the bunds formed in the wetlands. It consisted of the following parts.

##### 4.4.1 Prime Mover

As explained in Section 3.1.1, a 12 V DC motor, light in weight and capable of producing high torque was selected as the prime mover. Its speed was easily controlled and it could start and stop at fixed intervals. This permitted speed and position control. The specifications are provided in Appendix III.

##### 4.4.2 Profile Measuring Component

The methodology of development of the profile measuring component is described in Section 3.4.2. The profile measuring component was fabricated using

aluminium to ensure light weight and portability. It measured the distances in the X and Y directions. It was also integral to the device and the wired programming control, and sensors were mounted on it.

#### **4.4.3 Sensors**

Two HC-SR04 ultrasonic sensors were used in the instrument to measure the distances in the X and Y directions. The time taken by the sound pulse to travel the distance and reach back was measured and the distance to the target was calculated.

#### **4.4.4 SD Card Reader**

The SD card reader was incorporated to read and write data on to the 32 GB SD card.

#### **4.4.5 Program Development**

The Arduino UNO board was used for programming and a simple program was written using IDE for Arduino in order to measure the bund profile, as explained in Section 3.4.5. The specifications of the Arduino UNO board are presented in Appendix III. The program code is provided in Appendix IV.

#### **4.4.6 Electrical Circuits**

The arrangement of electrical circuits for operating the profile measuring instrument is explained in Section 3.4.6.

#### **4.4.7 Testing of the Profile Measuring Instrument**

The fabricated profile measuring implement was tested in the laboratory to validate its performance. The rectangular shape which was constructed in the laboratory was measured using the instrument and the readings were compared with the actually measured dimensions. All parts of the instrument worked satisfactorily. The profile of the rectangular shape fabricated was actually measured and is shown in Fig. 4.3.



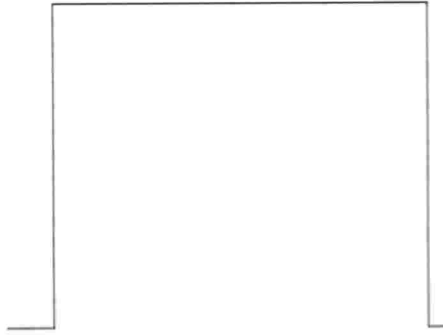

Fig. 4.3 Front view of the fabricated rectangular object (actually measured)

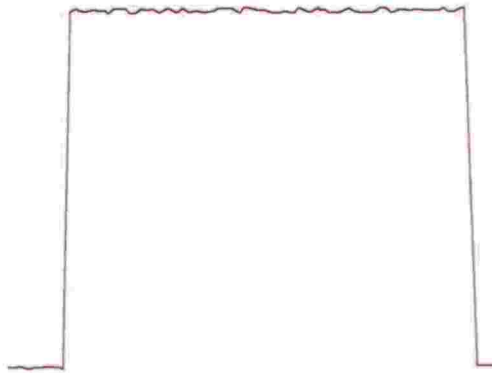

Fig. 4.4 Front view of the fabricated rectangular object measured by profile measuring instrument

Figure 4.4 shows the profile of the rectangular object obtained by using the profile measuring instrument. A paired t-test conducted on the two observations indicated that there was no significant difference between the actually measured and instrument-measured readings of the dimensions of the rectangular object, as the calculated t-values were less than the table t-values.

#### 4.5 FIELD TESTING AND PERFORMANCE EVALUATION OF BUND STRENGTHENING IMPLEMENT

The three models of bund strengthening implement were selected for testing and evaluation, and were operated at the selected test locations, as specified in Section 3.5.

### **4.5.1 Power Source**

The different power sources used for conducting the field testing are explained in Section 3.5.1. The depth of operation was fixed at the start of the trial run at 100 mm but the depth could not be maintained during operation, as the land was undulating, under water and depth measurement was not feasible.

### **4.5.2 Experimental Procedure**

The performance evaluation of the three models of bund strengthening implements that were developed were carried out as specified in Section 3.5.2.

### **4.5.3 Shape of Bund**

The bottom width, height and top width of the bunds formed using the different mechanical bund strengthening implements were observed and analysed as explained in Section 3.5.3. The results obtained are presented below.

#### **4.5.3.1 *Changes in Bund Dimensions Observed in Pullazhi kolepadavu***

The values of the bottom width, height, and top width of the bunds formed using the different models of the bund strengthening implement, as also the bunds formed manually, immediately after bund formation and on the third and seventh day after, were measured in the field and tabulated. The changes in the different bund dimensions at consecutive intervals are summarised in Tables 4.6 to 4.8.

##### **4.5.3.1.1 Bottom Width of Bunds**

The changes observed in the bottom width of the bunds are shown in Table 4.6. The maximum bottom width was noticeable with BF1 and the bottom widths of the bunds formed by BF3 and the BF2 were on par. The minimum value of bottom width was noticed for the bunds formed manually. This might be due to the fact that in the mechanised bund strengthening operation, the lower surface of the bund already existing from the previous season, may be undisturbed and new soil layers are deposited above this surface, with empty spaces also forming in between the deposited soil, due to presence of weeds or insufficient soil etc.

On the third day after bund formation, the bund bottom width increased slightly but the ordering of the bottom width, with respect to the different types of bund strengthening implements was readable in the same way as in the first day.

When the measurements of the bottom width of the formed bunds were taken seven days after the bund strengthening operation, a statistically insignificant ordering of the different bund strengthening implements was noticed with the bottom width of the bund formed by BF3 being the highest. The bottom width of the bund formed manually was still the lowest.

The bunds were formed using soils from the field along with water. Even though it was pressed through the bund strengthening implement, the bunds tended to settle down as they lost moisture. The soil on the bund became drier due to the reduction in moisture, within the bund, from the top to its bottom. The soil on the bund became drier due to the reduction in moisture, within the bund, from the top to its bottom. After seven days however, it was observed that the bunds stabilised, probably because further loss in moisture did not contribute to the settlement of the bund. The bunds tend to settle down over a period of time, thereby causing an increase in the dimension of the bunds formed.

Table 4.6 Summary of changes in bottom width of the bunds at consecutive intervals at Pullazhi *kole*

Sl. No.	Type of bund	Dimensions (cm)			% change	
		Day 1	Day 3	Day 7	D1 to D3	D3 to D7
1	Manual	22.30 <sup>b</sup>	23.20 <sup>b</sup>	23.90 <sup>b</sup>	4.04	3.02
2	Mechanically formed – BF1	25.05 <sup>a</sup>	26.95 <sup>a</sup>	28.10 <sup>a</sup>	7.58	4.37
3	Mechanically formed – BF2	23.64 <sup>ab</sup>	25.36 <sup>a</sup>	26.59 <sup>a</sup>	7.28	4.85
4	Mechanically formed – BF3	25.05 <sup>a</sup>	26.68 <sup>a</sup>	28.41 <sup>a</sup>	6.51	6.48
	CD	1.54	1.62	1.84		

#### 4.5.3.1.2 Height of bunds

Table 4.7 shows the changes observed in the height of bunds. A significantly superior height of bunds was noticed with respect to BF3, while all the other three processes under consideration yielded a height not significantly different. A decrease in heights that was read throughout the period of observation is only natural, as the bunds tend to settle down due to loss of moisture till they stabilise.

Table 4.7 Summary of changes in height of the bunds at consecutive intervals at Pullazhi kole

Sl. No.	Type of bund	Dimensions (cm)			% change	
		Day 1	Day 3	Day 7	D1 to D3	D3 to D7
1	Manual	14.85 <sup>b</sup>	13.65 <sup>b</sup>	12.40 <sup>b</sup>	-8.08	-9.16
2	Mechanically formed – BF1	15.15 <sup>b</sup>	13.90 <sup>b</sup>	13.50 <sup>b</sup>	-8.25	-2.88
3	Mechanically formed – BF2	15.14 <sup>b</sup>	13.86 <sup>b</sup>	13.23 <sup>b</sup>	-8.45	-4.55
4	Mechanically formed – BF3	22.59 <sup>a</sup>	19.91 <sup>a</sup>	17.68 <sup>a</sup>	-11.86	-11.20
	CD	1.77	1.63	1.62		

The height of the bunds formed by BF3 showed a greater decrease which may be due to the lesser extent of compaction of soil occurring during the formation of the bund using the KAMCO TeraTrac mini tractor.

#### 4.5.3.1.3 Top width of bunds

With regards to the top width, the ordering of the four processes under consideration was, bunds formed by BF1, (manual bund, BF2) and BF3 upto the third day. On the seventh day, however, a slight realignment of the sub-groups occurred; with the ordering of the sub-groups becoming as (BF1, manual), BF2 and BF3.

The bunds tend to settle down and spread in their dimensions as they lose the water by drying. They tended to arrive at a constant shape after a period of one week. Within this time, as increased solidification of the bund and settlement due to the loss of water happen, a slight increase in the bund top width and bottom width and decrease in the heights are read with respect to all the bunds formed. Air pockets, weeds incorporated into the bunds during formation etc. also contribute to the phenomenon. Table 4.8 summarises the changes occurring in the top width of the bunds formed.

Table 4.8 Summary of changes in top width of the bunds at consecutive intervals at Pullazhi kole

Sl. No.	Type of bund	Dimensions (cm)			% change	
		Day 1	Day 3	Day 7	D1 to D3	D3 to D7
1	Manual	16.55 <sup>b</sup>	17.80 <sup>b</sup>	19.50 <sup>c</sup>	7.55	9.55
2	Mechanically formed – BF1	13.95 <sup>c</sup>	15.30 <sup>c</sup>	18.05 <sup>c</sup>	9.68	17.97
3	Mechanically formed – BF2	18.00 <sup>b</sup>	19.68 <sup>b</sup>	21.64 <sup>b</sup>	9.33	9.96
4	Mechanically formed – BF3	20.59 <sup>a</sup>	22.64 <sup>a</sup>	23.73 <sup>a</sup>	9.96	4.81
	CD	1.95	2.05	1.95		

The variation in dimensions of the mechanically formed bunds was found to be greater than the manual bunds. The percentage change in bottom width, top width and height was however lesser from the third day to the seventh day as compared from first day to third day. The bunds tended to expand at the top and bottom and there was a decrease in height. This may be an indication that a greater force is required to compact the bund in such soils. Also it was observed that the mechanically formed bunds resulted in bunds with better height and top width than the manually formed bunds, after a period of seven days.

The variation in the different bund dimensions of the bunds formed using the different bund strengthening implement, with time, are plotted in Figure 4.5.

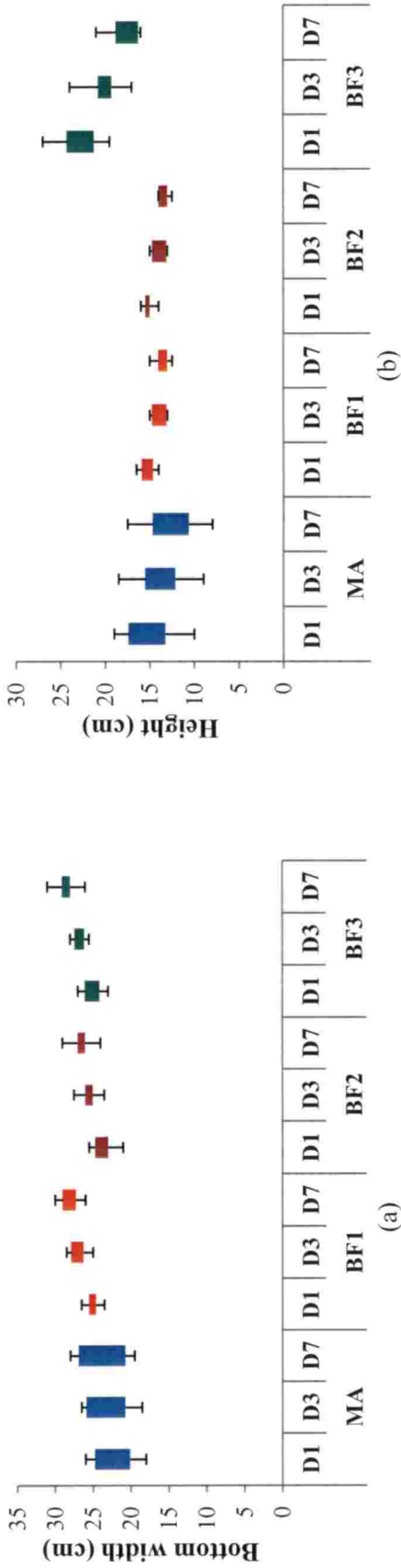

(a)

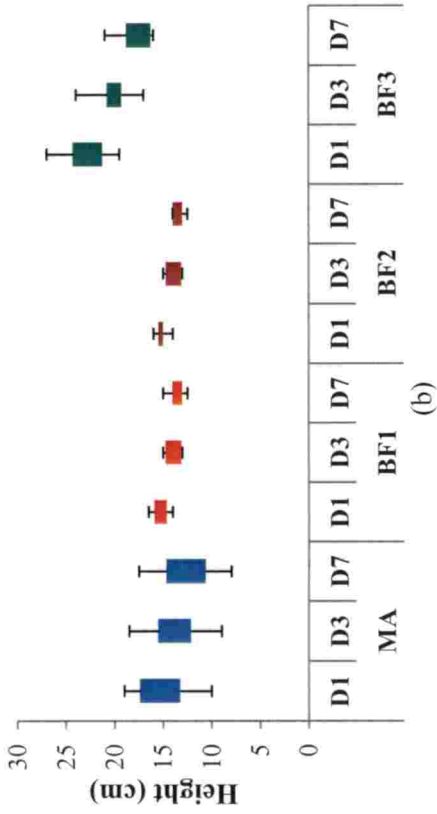

(b)

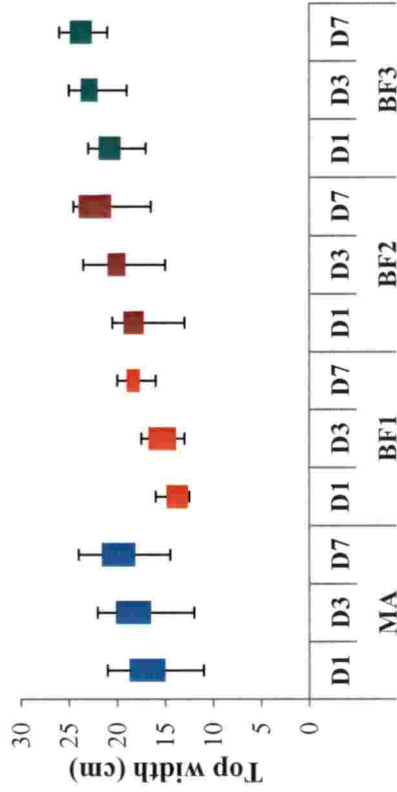

(c)

D1, D3 & D7 = Day 1, Day 3 & Day 7 of observations; MA - Manually formed bund; BF1, BF2 and BF3 – models of mechanical bund strengthening implement

Fig. 4.5 Variation in the different bund dimensions at Pullazhi kole

142

### 4.5.3.2 Changes in Bund Dimensions Observed in Ponnani kole

The trials were carried out at Kolothumpadam *kolepadavu*, Ponnani *kole* as per procedure explained in Section 3.5.2. The observations of the bottom width, height and top width of the bunds formed using the mechanical devices, as well as the readings of the bunds formed manually, were noted. The observations recorded are summarised in Tables 4.9 to 4.11.

#### 4.5.3.2.1 Bottom Width of Bunds

The bunds formed mechanically, using BF3, showed the maximum values for the bottom width of the bund, with an increase over the consecutive time intervals. On the first day, the values of the bottom width of the manually formed bunds followed the big bunds. The bunds formed by BF2 were the smallest while those resulting from BF4 were slightly larger in size. Table 4.9 shows the changes observed in bottom width of the formed bunds.

Table 4.9 Summary of changes in bottom width of the bunds at consecutive intervals at Ponnani *kole*

Sl. No.	Type of bund	Dimensions (cm)			% change	
		Day 1	Day 3	Day 7	D1 to D3	D3 to D7
1	Manual	34.06 <sup>b</sup>	39.15 <sup>a</sup>	40.28 <sup>a</sup>	14.94	2.89
2	Mechanically formed – BF2	26.62 <sup>d</sup>	30.23 <sup>b</sup>	32.00 <sup>b</sup>	13.56	5.86
3	Mechanically formed – BF3	36.89 <sup>a</sup>	38.62 <sup>a</sup>	39.04 <sup>a</sup>	4.69	1.09
4	Mechanically formed – BF4	28.23 <sup>c</sup>	29.97 <sup>b</sup>	30.83 <sup>b</sup>	6.16	2.87
	CD	1.72	1.88	1.84		

Subsequently on the third and the seventh day after the bund formation, the bunds formed by BF3 and the manually formed bunds were seen to be on par in terms of the bottom width of bund; as were the bunds formed by BF2 and the bunds formed by BF4.

The bunds formed by BF3 had a higher dimension due to the size of the implement. The change in dimensions over the time period of observation was also less in case of these bunds. The manually formed bunds tended to spread out

and the change in their dimensions from the first day to the third day was the largest, indicating a reduced compaction and loose packing of soil. This led to the spreading out of the manually formed bunds.

As the mechanical bund strengthening implements were operated over the remnants of the bunds from the previous season, BF2 would not be able to disturb the remnant bund and the implement could deposit soil, as per its dimension, on the top of the previous season's bund, leading to a lesser bottom width, initially.

The same effect could be observed when the operation using BF4 caused a further packing; thus displaying a lower value for bottom width of the bund. However, the bunds formed by BF2 were not sufficiently compacted as they displayed an increased change in dimension from the first day to the third day, as seen with the manually formed bunds. Lesser differential change in dimension was observed for bunds formed by BF4, indicating a better packing and stability in shape.

#### 4.5.3.2.2 Height of Bunds

Table 4.10 summarises the changes in height of the different types of bunds formed in Ponnani *kole* lands.

Table 4.10 Summary of changes in height of the bunds at consecutive intervals at Ponnani *kole*

Sl. No.	Type of bund	Dimensions (cm)			% change	
		Day 1	Day 3	Day 7	D1 to D3	D3 to D7
1	Manual	23.60 <sup>b</sup>	18.13 <sup>b</sup>	12.46 <sup>c</sup>	-23.18	-31.27
3	Mechanically formed – BF2	14.46 <sup>d</sup>	13.15 <sup>c</sup>	12.54 <sup>c</sup>	-9.06	-4.64
2	Mechanically formed – BF3	25.15 <sup>a</sup>	23.65 <sup>a</sup>	23.27 <sup>a</sup>	-5.96	-1.61
4	Mechanically formed –BF4	20.76 <sup>c</sup>	19.00 <sup>b</sup>	18.53 <sup>b</sup>	-8.48	-2.47
	CD	1.50	1.74	1.74		

144



The observations on the third day also showed a similar trend. The height of bund formed by BF2 was the minimum, while the bunds formed by BF4 and the manually formed bunds were on par. The maximum height was noted for the mechanically operated BF3. On the seventh day after the bund formation, bunds formed by BF3 and BF4 remained in the same order as earlier, while the height of the manually formed bund decreased and it became on par with the bund formed by BF2. Greatest change in height, over the period of observation, was seen in case of the manually formed bunds, again indicating that the shape of the bund does not stabilise, probably due to lesser compaction.

#### 4.5.3.2.3 Top Width of Bunds

The maximum value of the top width of the bunds was observed for those formed by BF3, throughout the period of observation. Though the dimensions formed by both BF4, and the bunds formed manually, were on par on the day of bund formation; later BF4 showed a higher reading compared to the manual bund. The values of the top width were consistently lower for the bunds formed by BF2 due to its reduced dimension, and by the seventh day, the manually formed bunds were on par with the bunds formed by BF2.

Table 4.11 shows the changes in the top width of the different types of bunds at Kolothumpadam *kolepadavu*, Ponnani *kole*.

Table 4.11 Summary of changes in top width of the bunds at consecutive intervals at Ponnani *kole*

Sl. No.	Type of bund	Dimensions (cm)			% change	
		Day 1	Day 3	Day 7	D1 to D3	D3 to D7
1	Manual	20.36 <sup>b</sup>	19.34 <sup>c</sup>	18.83 <sup>c</sup>	-5.01	-2.64
2	Mechanically formed – BF2	15.42 <sup>c</sup>	16.23 <sup>d</sup>	17.96 <sup>c</sup>	5.25	10.66
3	Mechanically formed – BF3	23.22 <sup>a</sup>	23.77 <sup>a</sup>	26.89 <sup>a</sup>	2.37	13.13
4	Mechanically formed –BF4	19.67 <sup>b</sup>	21.10 <sup>b</sup>	22.20 <sup>b</sup>	7.27	5.21
CD		1.40	1.63	2.34		

145

Minimum variation in the bottom width, height, and top width of the bunds from the first day to the third day after formation was observed in the case of the bunds mechanically formed using BF3, followed by the bunds formed by BF4 treatment. The manually formed bunds showed the greatest variation in the bottom width, height and a decrease in top width, indicating a loss of shape. This may be attributed to the lower compaction of the bund achieved through the manual operation, which makes the bund to lose its dimensions over time.

Among the mechanically formed bunds, those formed using the BF2 showed a greater change from the day of formation to the third day. The bottom width almost stabilised by the seventh day, with only a 1.09 per cent variation in case of the BF3. The bunds formed by BF4 and the manually formed bunds showed almost similar changes, while the bunds formed by BF2 showed a variation of 5.86 per cent in the bottom width, indicating that the bottom portion of the bund was not tightly packed. Heights decreased from the third day to the seventh day. The least difference in height however happened in the bunds formed by the mechanical BF3, followed by BF4. But the variation in height of the manual bunds was the highest indicating a loose packing of soil in the bunds.

Though a flattening of the tops of bunds formed mechanically was observed throughout the period of observation; the highest being observed in BF3, indicating an expansion / loosening of soil from the top, the dimensions of the bunds formed were suitable for movement/ walking over the bunds. On the other hand it was observed that the soil from the sides of the manually formed bunds tended to fall off/ slide down, changing the shape slightly and thereby reducing the top width of the bund; however this change was reduced by the seventh day.

The top and the bottom widths of the bunds showed an increase in all cases except the top width of the manually formed bunds; indicating a slight spread of the loose and wet soil. In case of manually formed bunds, the packing of the soil was so loose that the soil from the top tended to flow/ slough off, reducing the top width, and the bund spread out at the bottom also. In all the methods of

bund formation, the height was seen to reduce over the time period, with the mechanically formed bunds showing a considerably lesser percentage of reduction as time progressed.

Figure 4.6 depicts the changes in the bottom width, height and top width of the bunds formed by the different bund strengthening implements at Ponnani *kole* lands, over the period of observation.

#### **4.5.3.3 Changes in Bund Dimensions Observed in Tavanur**

The field conditions at the paddy fields at Athalur, Tavanur were very different from the conditions both in Ponnani *kole* and Pullazhi *kole*. The farmer practice in the area was to form very wide and high bunds; much different from the practice at the *kole* lands. The soil had 59.77 per cent sand and only 5.46 per cent clay. Hence the trials were conducted with the aim of assessing the suitability of the mechanical bund strengthening implements in creating new bunds rather than strengthening the existing ones. Both the KTT and NH3230 were used a power sources here, to operate the bund strengthening implements.

##### **4.5.3.3.1 Bottom Width of Bunds**

As observed in the area, the manual bunds were the biggest, with the largest bottom width and least percentage change in dimensions over the time period of observation. Of the mechanical models used along with the NH 3230 tractor, BF3 had the maximum bottom width, with a lower variation in the dimension from day one to day seven, followed by BF2, BF4 and BF1. However, by day seven, BF1 was on par with BF4. The variation in bottom width, though, was seen to be less in BF4 as compared to BF2 and the BF1, both between the first day and the third day and also between the third day and seventh day, indicating that forming bunds using BF3 and BF4 resulted in a better packing of the bund. It was also observed that on the first day, the bunds formed by BF2 using KTT as the power source were on par with the bunds formed by NH 3230 using BF2, and BF4.

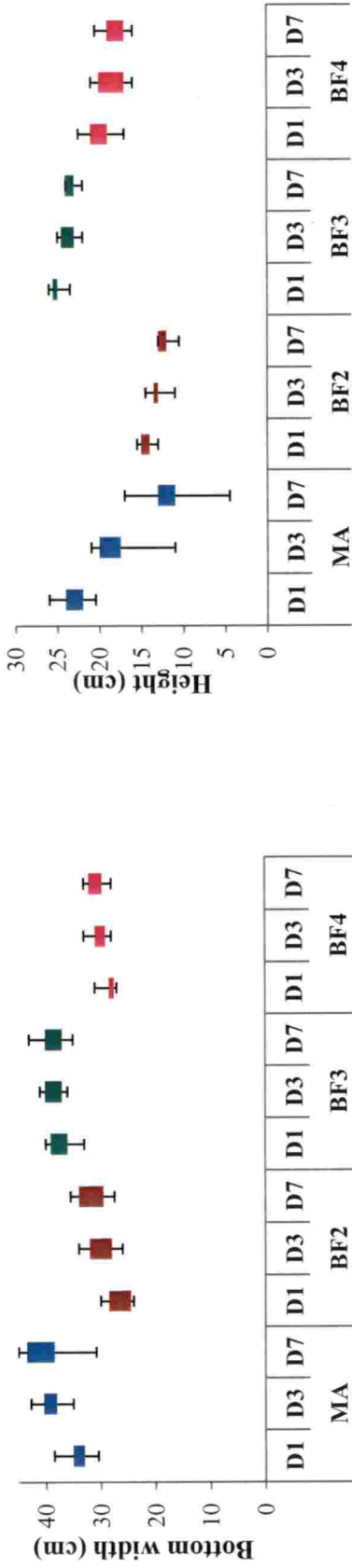

(a)

(b)

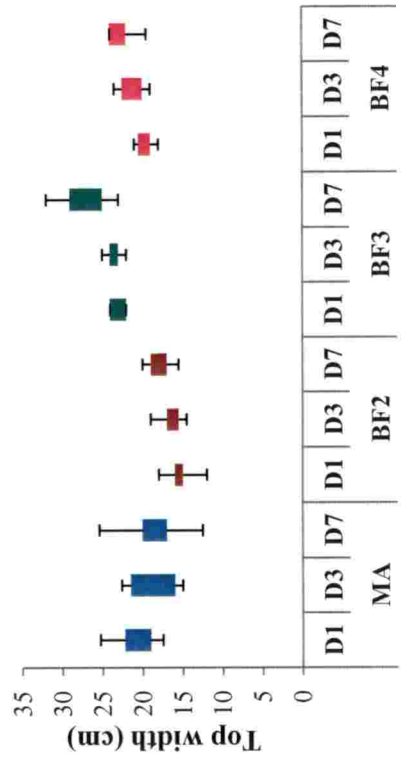

(c)

D1, D3 & D7 = Day 1, Day 3 & Day 7 of observations; MA - Manually formed bund; BF2 and BF3 – models of mechanical bund strengthening implement; BF4 – combination run of BF3 followed by BF2

Fig. 4.6 Variation in the different bund dimensions at Ponnani kole

168

The bunds formed using BF1 with both the KTT and NH 3230 tractor were also seen to be on par. On the third day it was seen that the bunds formed by BF2 using both types of power sources were on par as regards the bottom width and this reading was greater than the values of the bottom width of BF4.

The bottom widths of the bunds formed by BF1 using both power sources were also on par, but smaller. A similar trend was seen on the seventh day also. The bunds formed using BF1 and BF4 powered by the NH 3230 tractor were on par with the bunds formed by the BF1-KTT combination. The percentage change in the bottom width observed from the first day to the third day and from the third day to the seventh day after bund formation was more in the case of the bunds formed using KTT as the power source, which may point to the need of greater power for shaping the bunds in these soils.

The changes in the bottom width of the bunds are presented in Table 4.12.

Table 4.12 Summary of changes in bottom width of the bunds at consecutive intervals at Tavanur non-*kole* paddy fields

Sl. No.	Type of bund	Dimensions (cm)			% change	
		Day 1	Day 3	Day 7	D1 to D3	D3 to D7
1	Manual	41.00 <sup>a</sup>	43.47 <sup>a</sup>	44.27 <sup>a</sup>	6.02	1.84
2	Mechanically formed – BF1 + NH3230	20.80 <sup>e</sup>	23.90 <sup>e</sup>	26.20 <sup>d</sup>	14.90	9.62
3	Mechanically formed – BF2 + NH3230	27.73 <sup>c</sup>	30.63 <sup>c</sup>	31.87 <sup>c</sup>	10.46	4.05
4	Mechanically formed – BF3 + NH3230	34.67 <sup>b</sup>	36.80 <sup>b</sup>	37.87 <sup>b</sup>	6.14	2.91
5	Mechanically formed –BF4 + NH3230	24.83 <sup>d</sup>	26.90 <sup>d</sup>	27.90 <sup>d</sup>	8.34	3.72
6	Mechanically formed – BF1 + KTT	20.00 <sup>e</sup>	23.65 <sup>e</sup>	25.40 <sup>d</sup>	18.25	7.40
7	Mechanically formed – BF2 + KTT	26.09 <sup>cd</sup>	29.73 <sup>c</sup>	32.00 <sup>c</sup>	13.95	7.64
	CD	2.69	2.73	2.73		

#### 4.5.3.3.2 Height of Bunds

The changes in height of the bunds are presented in Table 4.13. Height of bund decreased over the time period of observation in all cases. The maximum value of bund height was observed in the manual bunds, as expected, followed by the bunds formed by mechanical model BF3. BF2 and BF4 gave on-par heights of bunds while height was the least for BF1. However, the least variation in height over time was observed in the case of BF4, followed by BF2 and BF1. The reduction in height of the bund formed by BF3 decreased by the seventh day. However, the percentage reduction from the third day to the seventh day was similar to that from the first day to the third day in case of the manually formed bunds. This indicated that the bund drying and settling process was still in progress for manual bunds.

Table 4.13 Summary of changes in height (cm) of the bunds at consecutive intervals at Tavanur (non-kole) paddy fields

Sl. No.	Type of bund	Dimensions (cm)			% change	
		Day 1	Day 3	Day 7	D1 to D3	D3 to D7
1	Manual	30.13 <sup>a</sup>	26.87 <sup>a</sup>	24.00 <sup>a</sup>	-10.82	-10.68
2	Mechanically formed – BF1 + NH3230	14.15 <sup>d</sup>	12.90 <sup>de</sup>	12.25 <sup>de</sup>	-8.83	-5.04
3	Mechanically formed – BF2 + NH3230	16.37 <sup>c</sup>	15.13 <sup>c</sup>	14.63 <sup>c</sup>	-7.58	-3.31
4	Mechanically formed – BF3 + NH3230	21.27 <sup>b</sup>	18.50 <sup>b</sup>	17.37 <sup>b</sup>	-13.02	-6.11
5	Mechanically formed – BF4 + NH3230	15.90 <sup>c</sup>	14.87 <sup>c</sup>	14.50 <sup>c</sup>	-6.48	-2.49
6	Mechanically formed – BF1 + KTT	13.40 <sup>d</sup>	11.80 <sup>e</sup>	10.95 <sup>e</sup>	-11.94	-7.20
7	Mechanically formed – BF2 + KTT	15.64 <sup>c</sup>	14.36 <sup>cd</sup>	13.32 <sup>cd</sup>	-8.18	-7.24
CD		1.42	1.85	1.70		

Also, it was observed that the bunds formed by BF2-KTT combination were on par with the bunds formed by using the NH 3230 in combination with

BF2, BF1 and BF4 on the first day. BF1-KTT combination gave bunds which were similar to the bunds formed by BF1 powered by NH3230 tractor. By the third day, it was observed that BF2-NH 3230, BF4-NH 3230, BF1- NH 3230 and the BF2-KTT combinations resulted in similar bunds. The bunds formed using BF1 with KTT as power source was on par only with the BF1-NH 3230 combination. The same trend was observed on the seventh day also. The reduction in height from the third day to the seventh day is however greater in the case of the bunds formed with the mini tractor as the power source, indicating that the bunds might be less compacted.

#### 4.5.3.3.3 Top Width of Bunds

The top width showed an increase over time and the observations are presented in Table 4.14.

Table 4.14 Summary of changes in top width (cm) of the bunds at consecutive intervals at Tavanur (non-*kole*) paddy fields

Sl. No.	Type of bund	Dimensions (cm)			% change	
		Day 1	Day 3	Day 7	D1 to D3	D3 to D7
1	Manual	31.50 <sup>a</sup>	35.67 <sup>a</sup>	38.27 <sup>a</sup>	13.24	7.29
2	Mechanically formed – BF1 + NH3230	14.05 <sup>c</sup>	14.90 <sup>c</sup>	16.20 <sup>d</sup>	6.05	8.73
3	Mechanically formed – BF2 + NH3230	17.27 <sup>c</sup>	24.53 <sup>c</sup>	25.03 <sup>c</sup>	42.04	2.04
4	Mechanically formed – BF3 + NH3230	26.43 <sup>b</sup>	29.13 <sup>b</sup>	30.20 <sup>b</sup>	10.22	3.67
5	Mechanically formed – BF4 + NH3230	14.73 <sup>de</sup>	16.23 <sup>e</sup>	17.10 <sup>d</sup>	10.18	5.36
6	Mechanically formed – BF1 + KTT	13.05 <sup>e</sup>	14.40 <sup>e</sup>	15.65 <sup>d</sup>	10.34	8.68
7	Mechanically formed – BF2 + KTT	16.41 <sup>cd</sup>	20.46 <sup>d</sup>	22.77 <sup>c</sup>	24.68	11.29
CD		2.08	2.59	2.82		

The top width was highest for the manually formed bunds. Among the bunds formed mechanically using the NH 3230 tractor, the bunds formed by BF3 were followed by those formed by BF2 in top width. The dimensions of the bunds formed by BF1 and BF4 were seen to be on par. When the bunds were formed using BF1 and BF2 powered by KTT, it was seen that on the first day, the bunds formed by BF2 were on par with those formed by the same model using the bigger power source, i.e., the NH 3230 tractor. Similarly, the bunds formed by BF1-KTT combination was on par with the bunds formed by BF1 in combination with the higher power source, though these had the smallest dimensions.

By the third day, the order of the top width of the formed bunds were as bunds formed manually followed by the bunds formed by BF3, BF2-NH3230, BF2-KTT. The bunds formed by BF1 with both power sources and BF4 with NH3230 were on par and the least. By the seventh day, the same trend was observed for BF1 with both power sources and BF4 with NH3230, but the bunds formed by BF2 using both power sources had become comparable.

Figures 4.7 and 4.8 shows the changes in the different bund dimensions of the various types of bunds formed, over the observation period using KTT and NH 3230 as power sources.

#### **4.5.3.4 Bund Profile**

The profile of the bunds formed at the various locations could not be determined by the commonly used pin type profile meter. Hence a non-contact type, ultra sonic sensor based profile measuring instrument was developed as explained in Section 3.4. The readings were stored in the data card and later transferred to the AutoCAD software and profile of the various bunds was plotted, based on the mean values. The plots are presented in Figures 4.9 to 4.12.



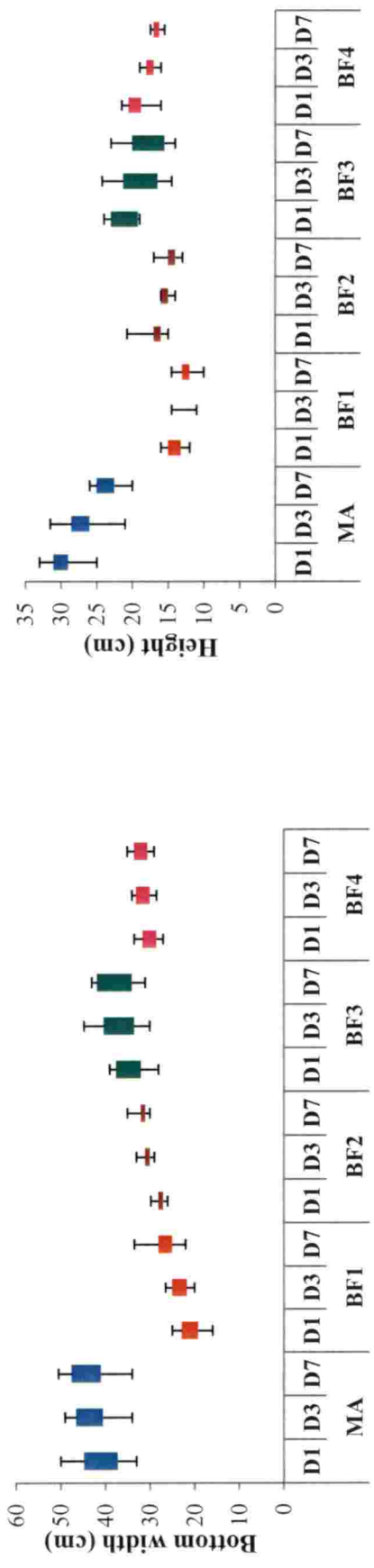

(a)

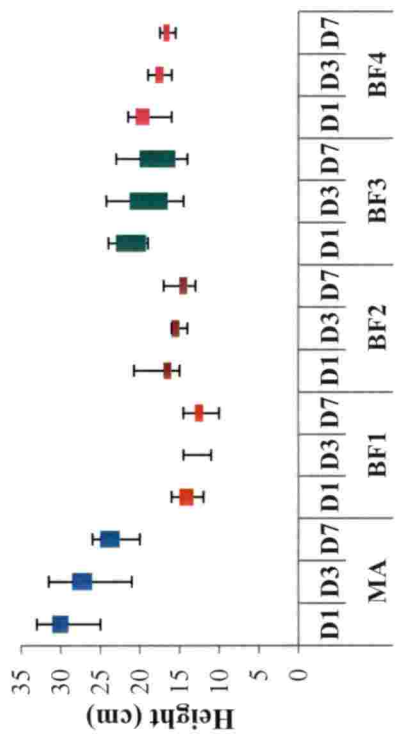

(b)

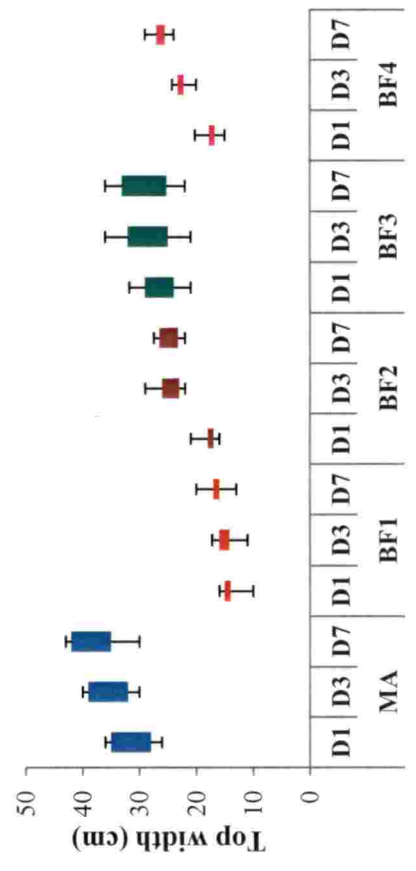

(c)

D1, D3 & D7 = Day 1, Day 3 & Day 7 of observations; MA – Manually formed bund; BF1, BF2, BF3 – models of mechanical bund strengthening implement; BF4 – combination run of BF3 followed by BF2

Fig. 4.7 Variation in the different bund dimensions at Tavanur (Power source : NH 3230)

153

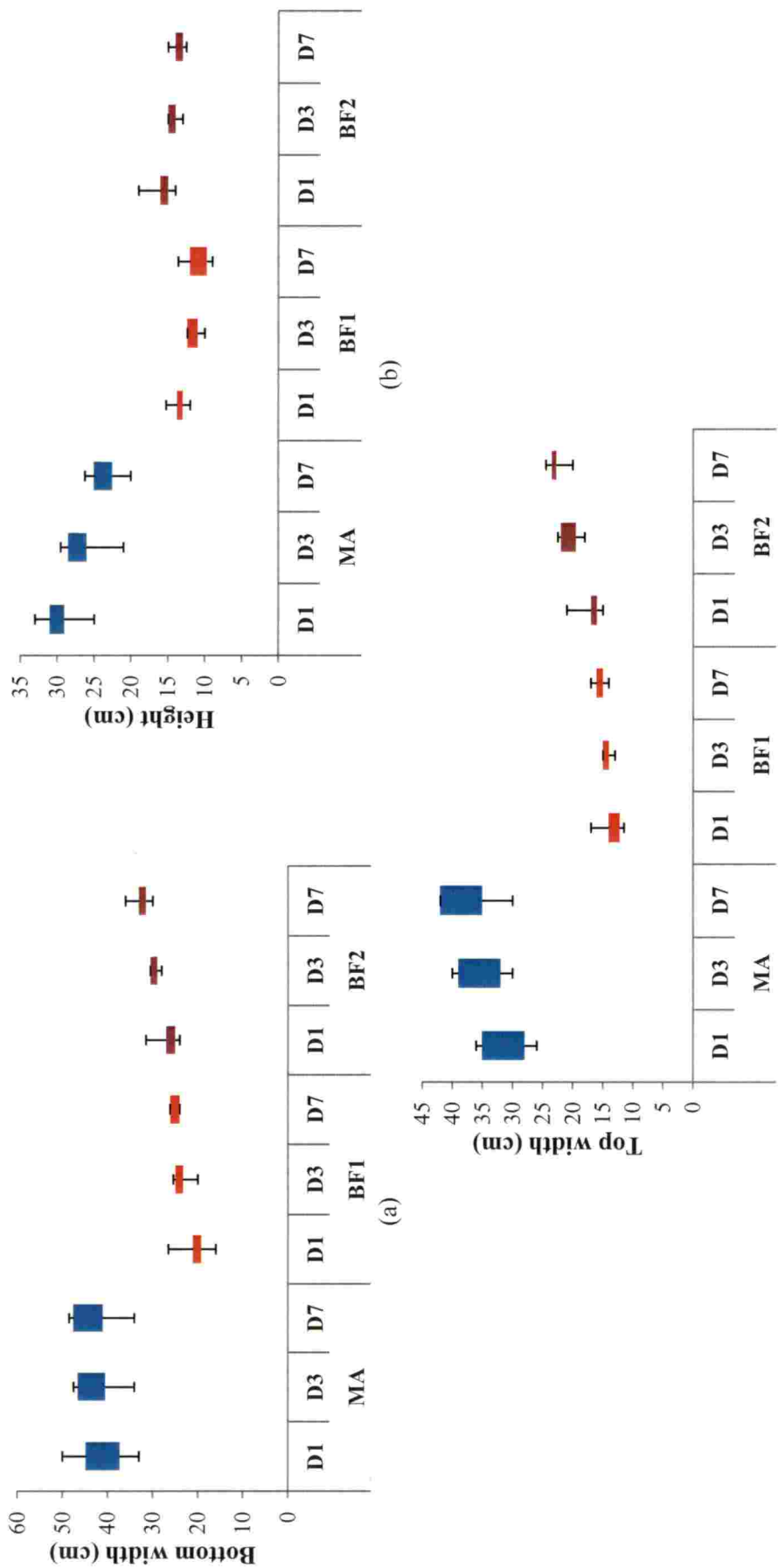

D1, D3 & D7 = Day 1, Day 3 & Day 7 of observations; MA – Manually formed bund; BF1, BF2 – models of mechanical bund strengthening implement

Fig. 4.8 Variation in the different bund dimensions at Tavanur (Power source : KTT)

157

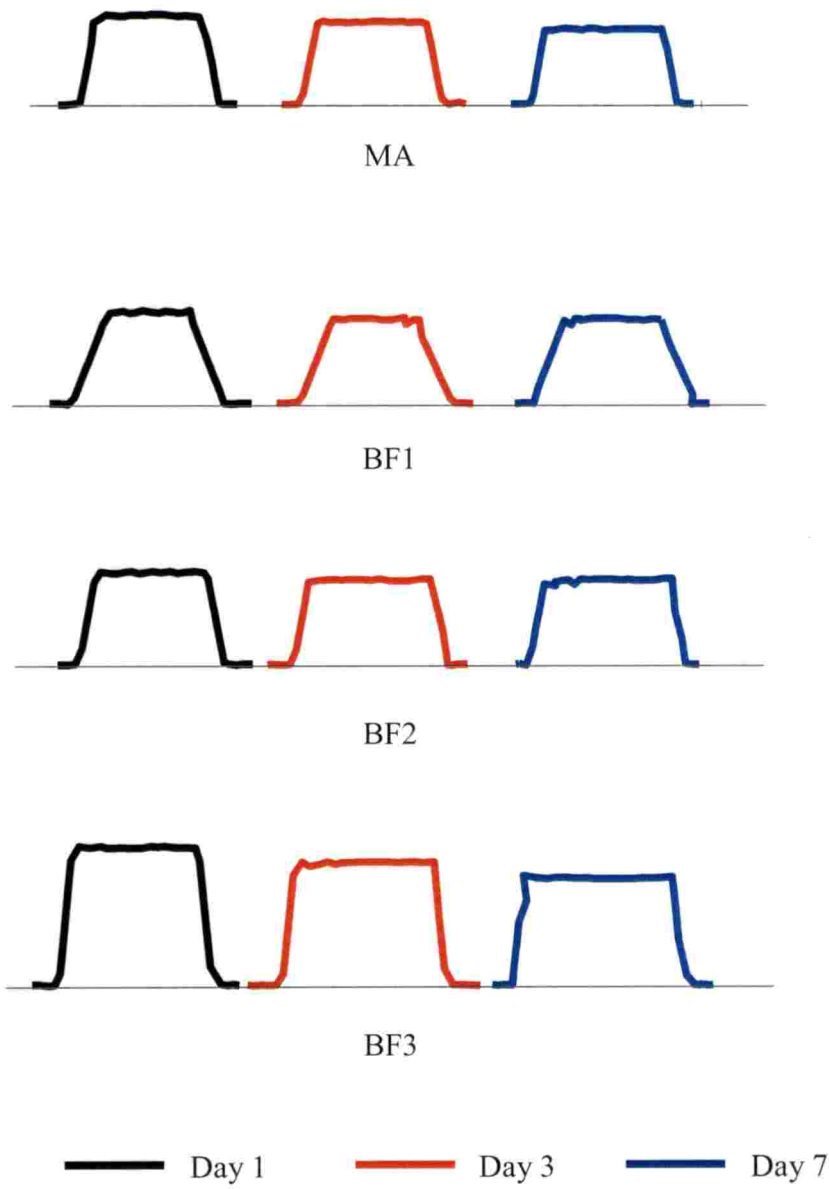

Fig. 4.9 Bund profile plotted using profile measuring instrument at Pullazhi kolepadavu, Thrissur kole

155

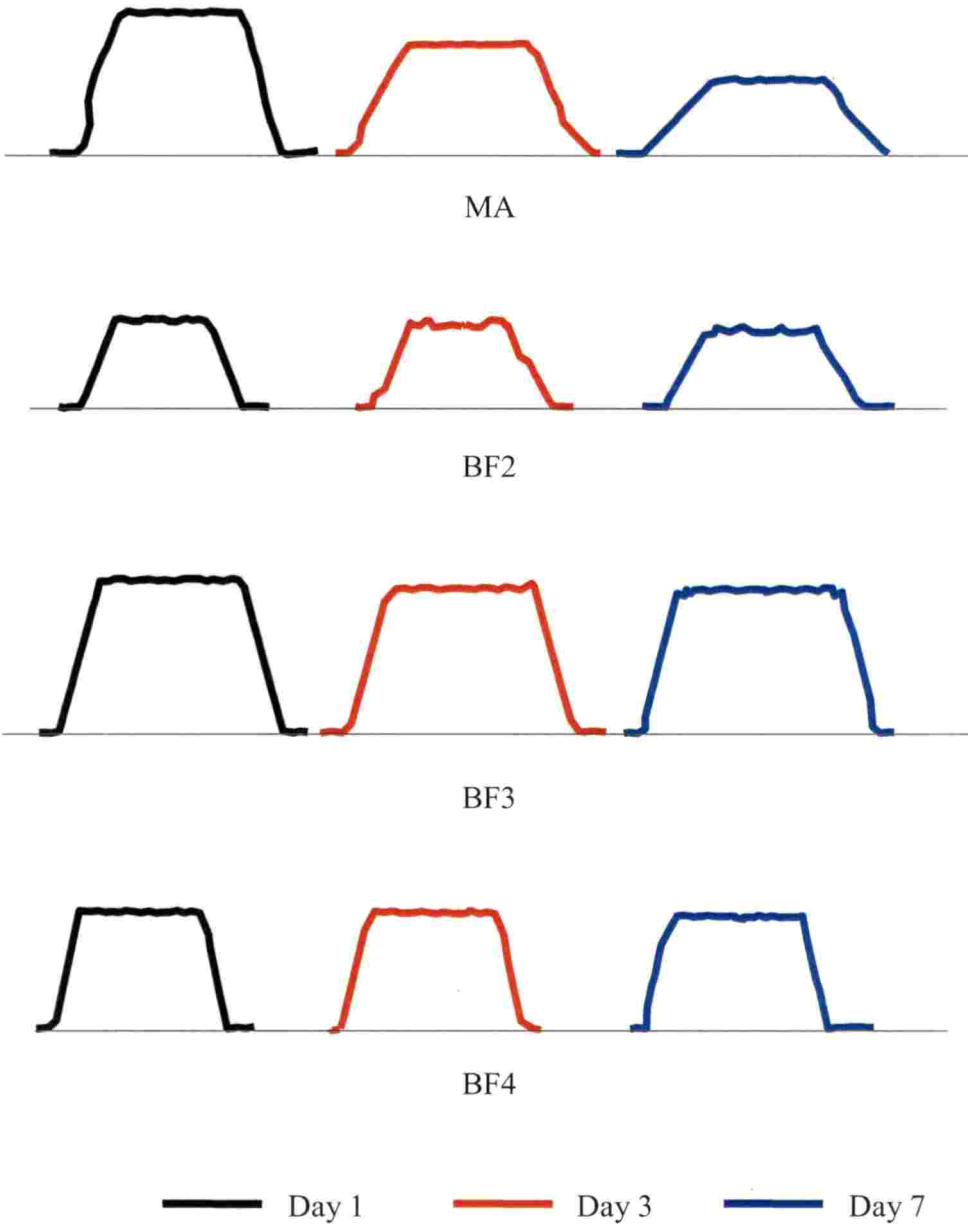

Fig. 4.10 Bund profile plotted using profile measuring instrument at Kolothumpadam *kolepadavu*, Ponnani *kole*

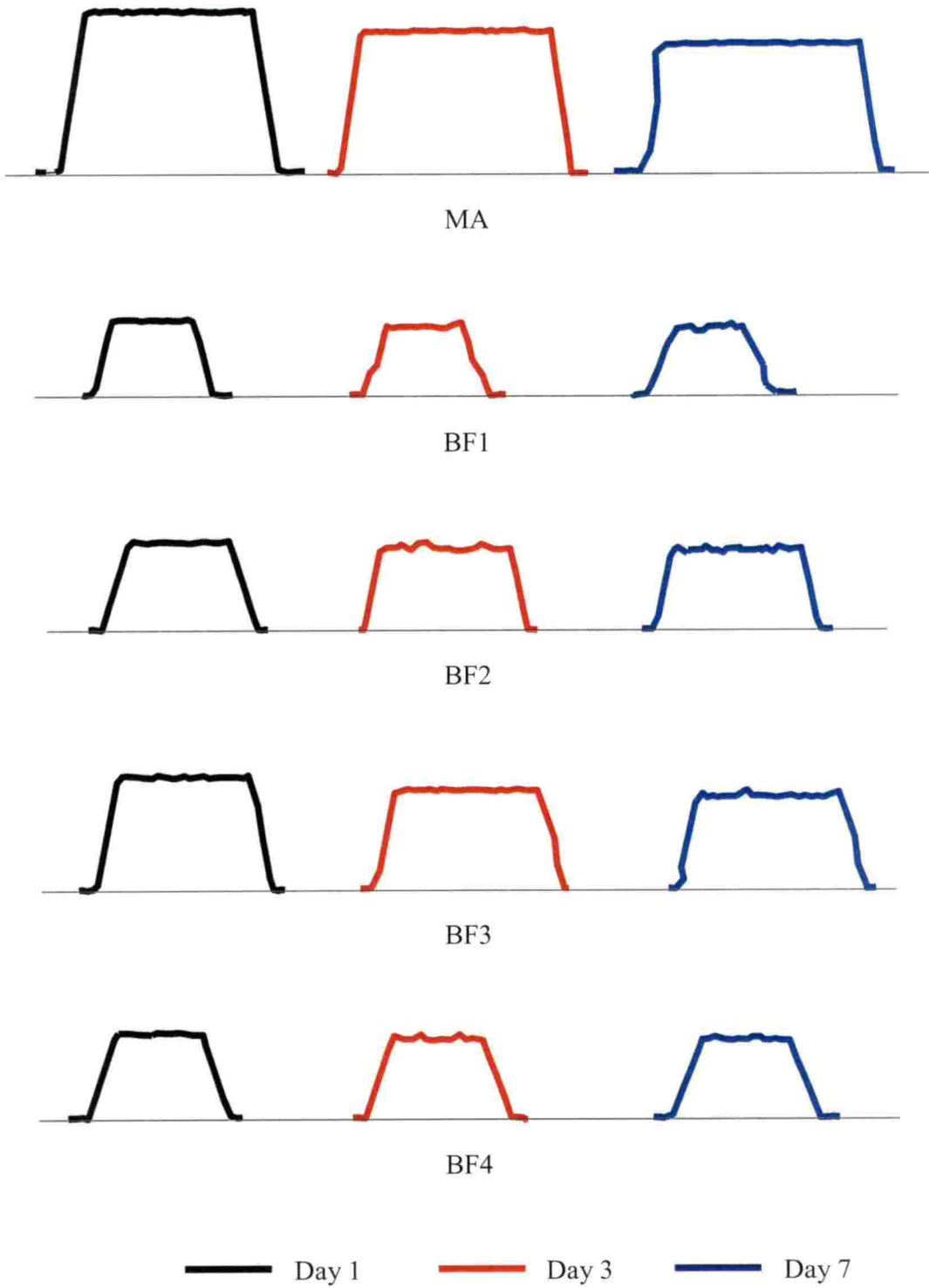

Fig. 4.11 Bund profile plotted using profile measuring instrument at Tavanur  
(Power source: NH 3230)

153

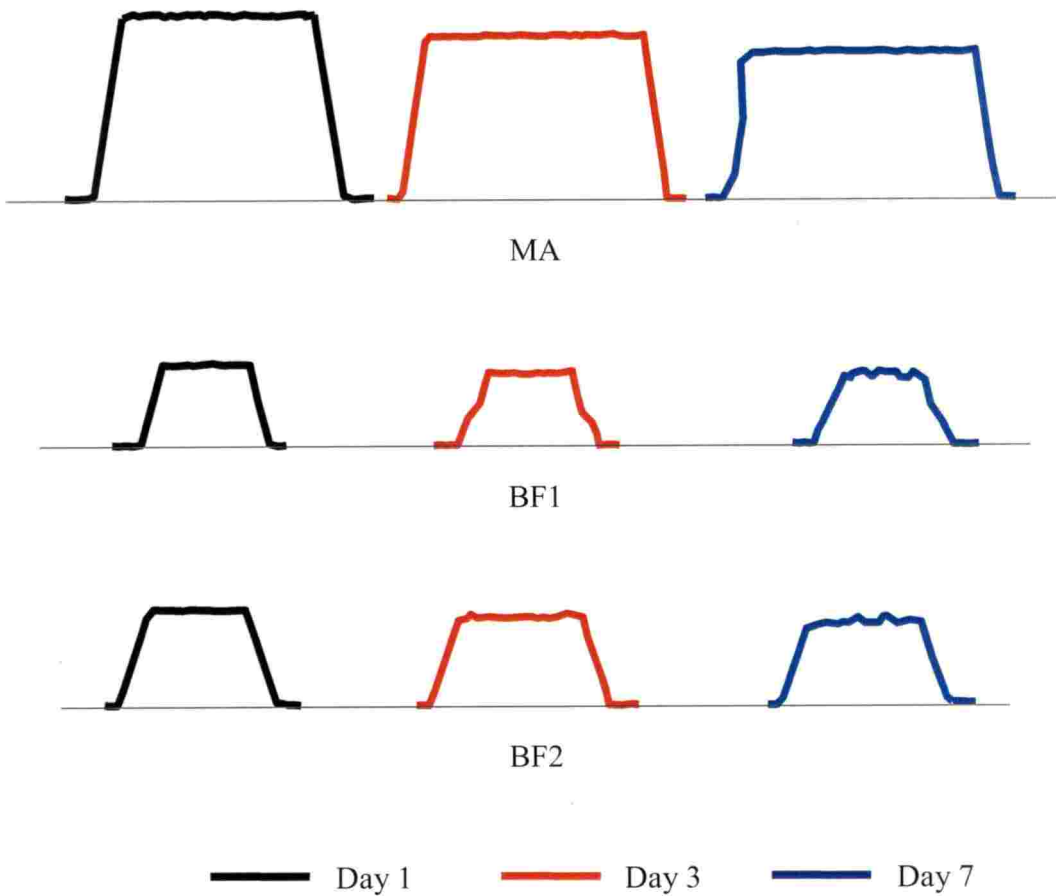

Fig. 4.12 Bund profile plotted using profile measuring instrument at Tavanur (Power source : KTT)

Consolidation or compaction of soil increases its mechanical strength. When soil is compacted by any mechanical means, its density increases. In unsaturated soils, the air volume is reduced during the densification process. Compaction is difficult in saturated soils as the higher water content would affect the soil compressibility negatively.

#### 4.5.4 Penetration Resistance (Cone Index) of Formed Bunds

Soil cone index is the force exerted by the soil on the base area of the conical head of the cone penetrometer as it is pushed through the soil down a

specific depth. The cone index of the soil is an indication of its strength and it can be used as an assessment indicator of compaction of soil. The results of the observation of cone index values measured on the formed bunds are presented below.

#### 4.5.4.1 Changes in Cone Index Observed in the Bunds Formed at Pullazhi kole

The summary of changes in the values of cone index recorded in the various types of bunds formed, along its profile, is shown in Tables 4.15 to 4.18.

Table 4.15 Summary of changes in cone index ( $\text{kg cm}^{-2}$ ) at different depths within bund formed using BF3 at consecutive intervals at Pullazhi kole

Sl. No.	Depth (cm)	Cone Index ( $\text{kg cm}^{-2}$ )		
		Day 1	Day 3	Day 7
1	7.50	0.43 <sup>g</sup>	0.71 <sup>f</sup>	1.47 <sup>g</sup>
2	10.00	0.57 <sup>g</sup>	0.76 <sup>f</sup>	1.53 <sup>g</sup>
3	12.50	1.25 <sup>f</sup>	2.07 <sup>e</sup>	2.71 <sup>f</sup>
4	15.00	2.47 <sup>e</sup>	3.21 <sup>d</sup>	4.28 <sup>e</sup>
5	17.50	4.18 <sup>d</sup>	4.83 <sup>c</sup>	6.28 <sup>d</sup>
6	20.00	5.33 <sup>c</sup>	6.40 <sup>b</sup>	6.86 <sup>c</sup>
7	22.50	6.68 <sup>b</sup>	6.86 <sup>ab</sup>	7.16 <sup>bc</sup>
8	25.00	7.41 <sup>a</sup>	7.17 <sup>a</sup>	7.36 <sup>ab</sup>
9	27.50	7.58 <sup>a</sup>	7.41 <sup>a</sup>	7.52 <sup>a</sup>
10	30.00	7.59 <sup>a</sup>	7.47 <sup>a</sup>	7.52 <sup>a</sup>
	CD	0.41	0.63	0.30

As observed from Table 4.15, the cone index values increased as the depth of recording increased, which was as per expectation. Initially, because of the higher moisture content, the cone index values were relatively lower at the initial depths and these gradually increased with increasing depths. For the bunds formed by BF3 it varied from  $0.43 \text{ kg cm}^{-2}$  at a depth of 7.5 cm to  $7.59 \text{ kg cm}^{-2}$  at a depth of 30.0 cm on the first day of bund formation. When these readings were repeated on the third day, slightly higher values were observed for the cone index but its trajectory in relation to the depth of the bund remained the same; with the value at the highest observed depth touching  $7.47 \text{ kg cm}^{-2}$ . However, in comparison with

the first day, a slight decrease in the values of the cone index was observed from a depth of 25.0 cm to 30.0 cm, which may be due to the effect of increased water levels in the field on the said day.

A further increase in the cone index values was observed on the seventh day as the water from the upper layers of the bund percolated downwards (the bunds dried out). The range of cone index values was from 1.47 kg cm<sup>-2</sup> at the depth of 7.5 cm from top of the bund to 7.52 kg cm<sup>-2</sup> at the depth of 30.0 cm. The values at the depths from 25.0 cm to 30.0 cm also showed an increase as the water level again reduced.

Table 4.16 Summary of changes in cone index (kg cm<sup>-2</sup>) at different depths within bund formed using BF2 at consecutive intervals at Pullazhikole

Sl. No.	Depth (cm)	Cone Index (kg cm <sup>-2</sup> )		
		Day 1	Day 3	Day 7
1	7.50	0.45 <sup>g</sup>	0.63 <sup>f</sup>	1.56 <sup>e</sup>
2	10.00	0.76 <sup>fg</sup>	0.90 <sup>ef</sup>	1.93 <sup>e</sup>
3	12.50	1.21 <sup>f</sup>	1.50 <sup>def</sup>	2.11 <sup>de</sup>
4	15.00	1.86 <sup>e</sup>	1.76 <sup>cde</sup>	3.36 <sup>cd</sup>
5	17.50	2.32 <sup>de</sup>	1.98 <sup>cd</sup>	4.51 <sup>bc</sup>
6	20.00	2.90 <sup>d</sup>	2.20 <sup>bcd</sup>	5.78 <sup>ab</sup>
7	22.50	4.26 <sup>c</sup>	2.60 <sup>bc</sup>	5.84 <sup>ab</sup>
8	25.00	5.56 <sup>b</sup>	2.82 <sup>bc</sup>	6.09 <sup>a</sup>
9	27.50	6.42 <sup>a</sup>	3.14 <sup>b</sup>	6.14 <sup>a</sup>
10	30.00	6.65 <sup>a</sup>	4.69 <sup>a</sup>	6.35 <sup>a</sup>
	CD	0.61	0.97	1.32

The same trend of increasing cone index values at increasing depths was observed for the bunds formed by BF2 (Table 4.16) and BF1 (Table 4.17). The cone index values on the first day ranged from 0.45 kg cm<sup>-2</sup> at a depth of 7.5 cm from the top of the bund to 6.65 kg cm<sup>-2</sup> at the depth of 30.0 cm, in case of the bunds formed using BF2. The strength of the bund increased with depth, along its profile. In case of BF1 this range of values was from 0.46 kg cm<sup>-2</sup> to 4.51 kg cm<sup>-2</sup>. The increasing trend was observed on the third day also. However, the decrease in the cone index values in case of the bunds formed by BF2 from depths 15.0 cm to



30.0 cm as compared to the first day may be due to the bunds remaining wet due to the standing water within these fields.

Table 4.17 Summary of changes in cone index ( $\text{kg cm}^{-2}$ ) at different depths within bund formed using BF1 at consecutive intervals at Pullazhi kole

Sl. No.	Depth (cm)	Cone Index ( $\text{kg cm}^{-2}$ )		
		Day 1	Day 3	Day 7
1	7.50	0.46 <sup>c</sup>	0.66 <sup>e</sup>	1.16 <sup>f</sup>
2	10.00	0.79 <sup>bc</sup>	0.83 <sup>e</sup>	1.41 <sup>f</sup>
3	12.50	1.11 <sup>bc</sup>	0.91 <sup>e</sup>	1.76 <sup>ef</sup>
4	15.00	1.42 <sup>bc</sup>	1.11 <sup>e</sup>	2.23 <sup>cdef</sup>
5	17.50	1.87 <sup>bc</sup>	1.70 <sup>de</sup>	2.01 <sup>def</sup>
6	20.00	2.37 <sup>abc</sup>	2.59 <sup>cd</sup>	3.00 <sup>bcd</sup>
7	22.50	2.91 <sup>ab</sup>	3.02 <sup>bcd</sup>	3.21 <sup>bcd</sup>
8	25.00	2.68 <sup>abc</sup>	3.93 <sup>bc</sup>	3.52 <sup>bc</sup>
9	27.50	1.92 <sup>bc</sup>	4.37 <sup>b</sup>	4.21 <sup>ab</sup>
10	30.00	4.51 <sup>a</sup>	5.83 <sup>a</sup>	5.19 <sup>a</sup>
	CD	2.04	1.39	1.21

The same trend of increasing cone index values at increasing depths was observed for the bunds formed by BF2 (Table 4.16) and BF1 (Table 4.17). The cone index values on the first day ranged from 0.45  $\text{kg cm}^{-2}$  at a depth of 7.5 cm from the top of the bund to 6.65  $\text{kg cm}^{-2}$  at the depth of 30.0 cm, in case of the bunds formed using BF2. The strength of the bund increased with depth, along its profile. In case of BF1, this range of values was from 0.46 to 4.51  $\text{kg cm}^{-2}$ . The increasing trend was observed on the third day also. However, the decrease in the cone index values in case of the bunds formed by BF2 from depths 15.0 cm to 30.0 cm as compared to the first day may be due to the bunds remaining wet due to the standing water within these fields.

The same increasing trend in the values of the cone index along the depths of the bunds was observed on the seventh day also, both for the bunds formed by BF2 and BF1.

A similar pattern of increasing cone index values was observed in the case of the manually formed bunds also, as shown in Table 4.18.

Table 4.18 Summary of changes in cone index ( $\text{kg cm}^{-2}$ ) at different depths within bund formed manually at consecutive intervals at Pullazhi *kole*

Sl. No.	Depth (cm)	Cone Index ( $\text{kg cm}^{-2}$ )		
		Day 1	Day 3	Day 7
1	7.50	0.20 <sup>g</sup>	0.32 <sup>d</sup>	0.83 <sup>c</sup>
2	10.00	0.26 <sup>fg</sup>	0.43 <sup>d</sup>	1.16 <sup>c</sup>
3	12.50	0.29 <sup>fg</sup>	0.42 <sup>d</sup>	1.79 <sup>bc</sup>
4	15.00	0.34 <sup>efg</sup>	0.48 <sup>d</sup>	2.57 <sup>ab</sup>
5	17.50	0.42 <sup>ef</sup>	0.48 <sup>d</sup>	3.04 <sup>a</sup>
6	20.00	0.46 <sup>c</sup>	0.54 <sup>d</sup>	3.70 <sup>a</sup>
7	22.50	0.68 <sup>d</sup>	0.62 <sup>d</sup>	3.41 <sup>a</sup>
8	25.00	0.90 <sup>c</sup>	1.39 <sup>c</sup>	3.28 <sup>a</sup>
9	27.50	1.27 <sup>b</sup>	2.69 <sup>b</sup>	3.05 <sup>a</sup>
10	30.00	2.51 <sup>a</sup>	4.29 <sup>a</sup>	3.07 <sup>a</sup>
	CD	0.15	0.74	1.09

The changes in cone index values at incremental depths over consecutive time intervals for the different types of bunds formed at Pullazhi *kole* are plotted below in Fig. 4.13.

It is observed that the values of the cone index are higher for the mechanically formed bunds at all depths, when compared to the manually formed ones. Among the mechanically formed bunds, the cone index values of the bunds formed by BF3 were observed to be higher at greater depths; which may be due to that fact that as the bunds are formed over the pre-existing ones, the remnants of the compacted soil from the previous season are present at the bottom of the bund and add to the value of the cone index.

Since the height of the bunds formed by BF2 and BF1 are less, and most of the bund is formed using the disturbed soil as compared to the bunds formed by BF3, the resistance offered by the soil is lesser here. The resistance offered by the soil in case of manually formed bunds is least, indicating that these bunds have lesser strength.

162

Change in cone index (kgcm<sup>-2</sup>) at different depths in manually formed bunds

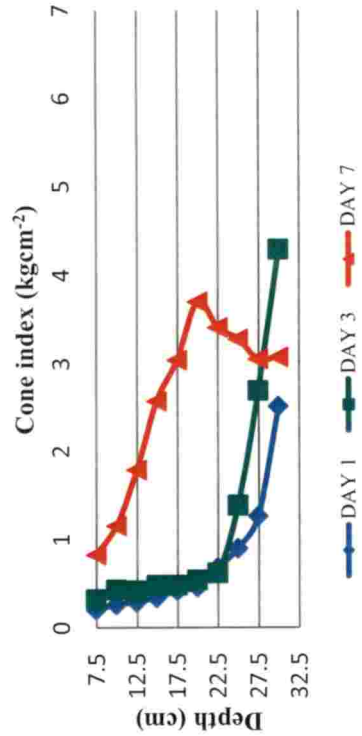

Change in cone index (kgcm<sup>-2</sup>) at different depths in bunds fomed using BF1

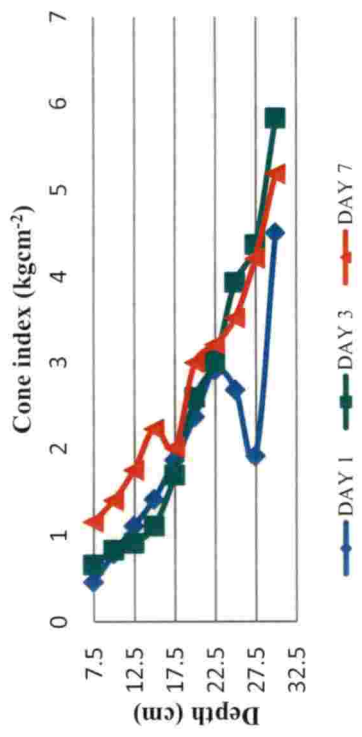

Change in cone index (kgcm<sup>-2</sup>) at different depths in bunds fomed using BF2

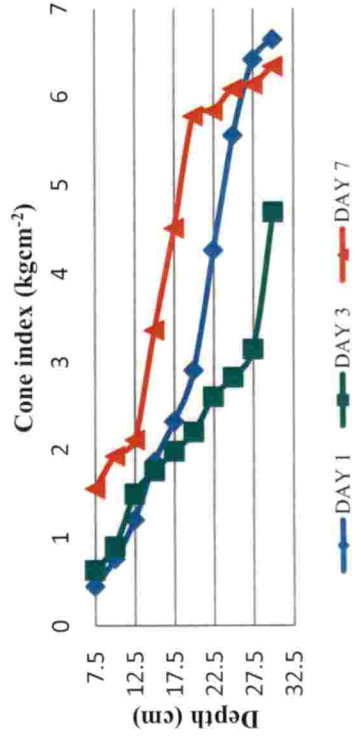

Change in cone index (kgcm<sup>-2</sup>) at different depths in bunds fomed using BF3

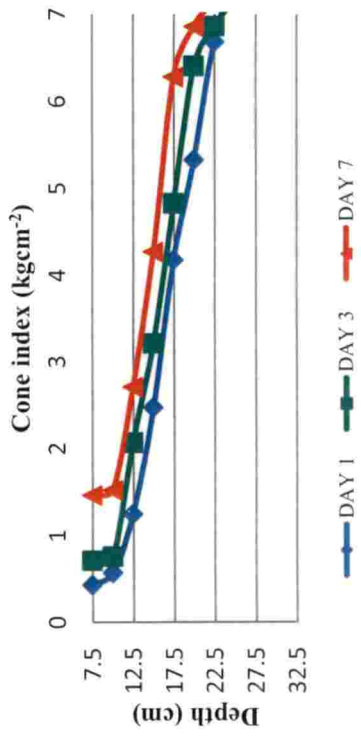

Fig. 4.13 Changes in cone index at increasing depths within different types of bunds at Pullazhi kole

163

The changes in the values of cone index at different depths across the bunds formed using the different methods of bund formation, at consecutive time intervals of observation are depicted in Figures 4.14 to 4.16. The values of the cone index are provided in Appendix V.

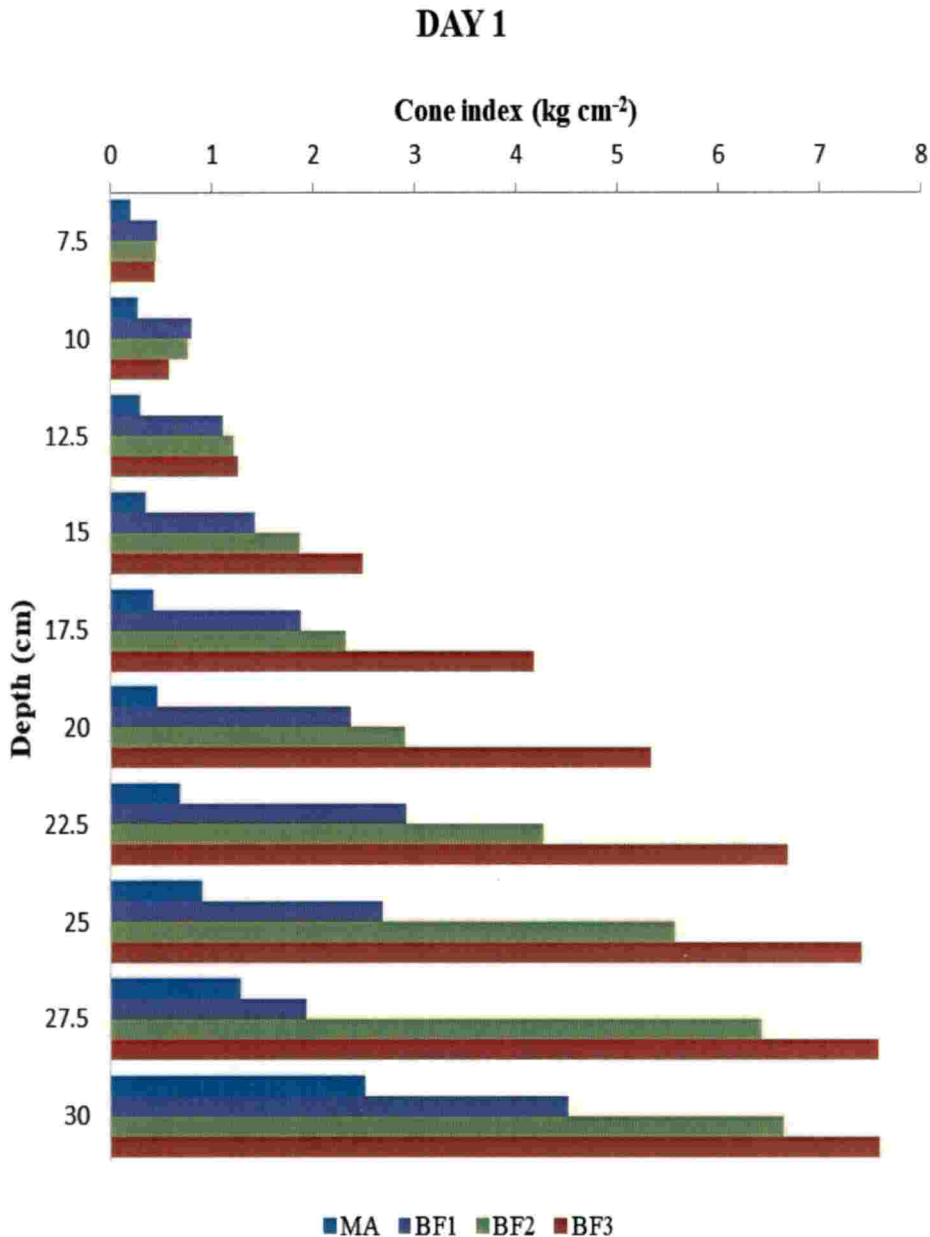

Fig. 4.14 Variation of cone index with depth, on Day 1, in different types of bunds formed

Figures 4.14 to 4.16 indicate that the values of cone index show a steady increase as the depth from the top layer increases at all the observation intervals. On the first day the values of cone index were low for the initial depths, while these gradually increased as time elapsed, indicating that the top layers got firmer as the bunds dried out. The lower values of cone index for the manually formed bunds indicated a lower penetration resistance offered by the bund, which shows that the bund compaction is lesser in this case.

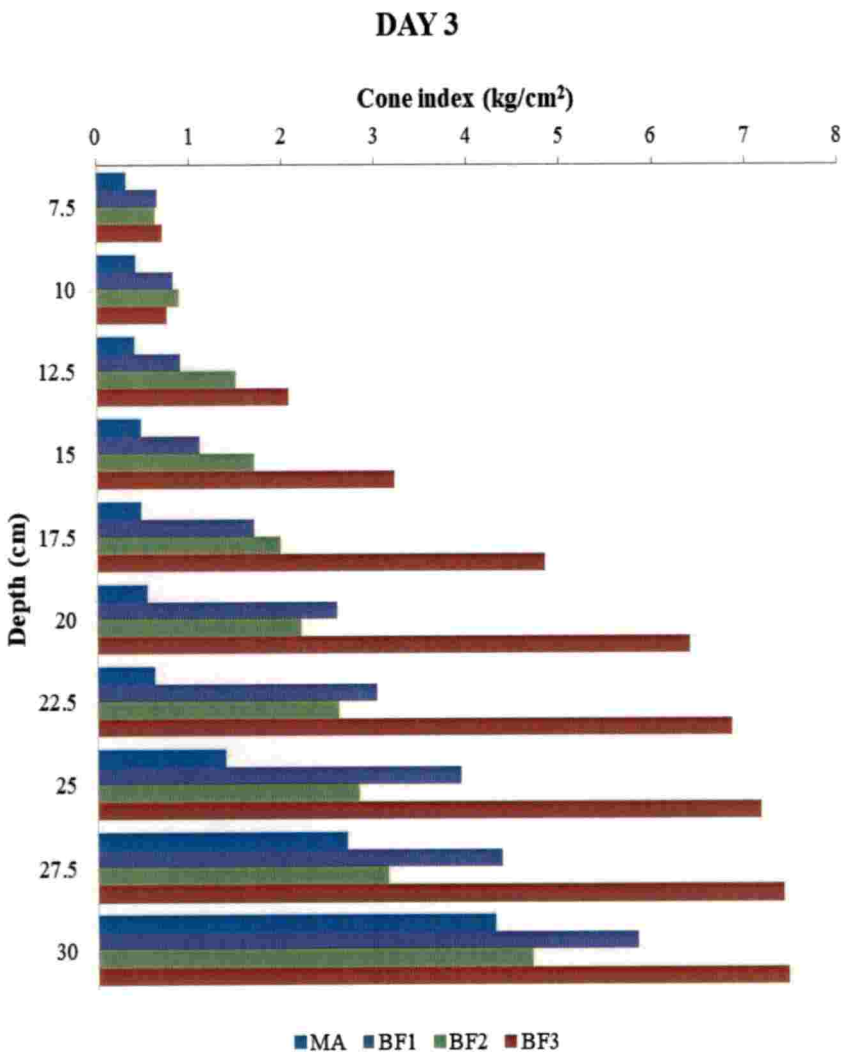

Fig. 4.15 Variation of cone index with depth, on Day 3 in different types of bunds formed

165

The bunds formed mechanically using BF3 showed the highest resistance to penetration of the cone penetrometer, indicating that this bund was compacted better. The bunds formed by BF2 showed a lower value for cone index at greater depths on the third day as compared to the bunds formed by BF1 indicating a lower strength. By the seventh day their strength increased above that of the bunds formed by BF1. Generally, the strength of all the bunds increased both with depth and with the passage of time.

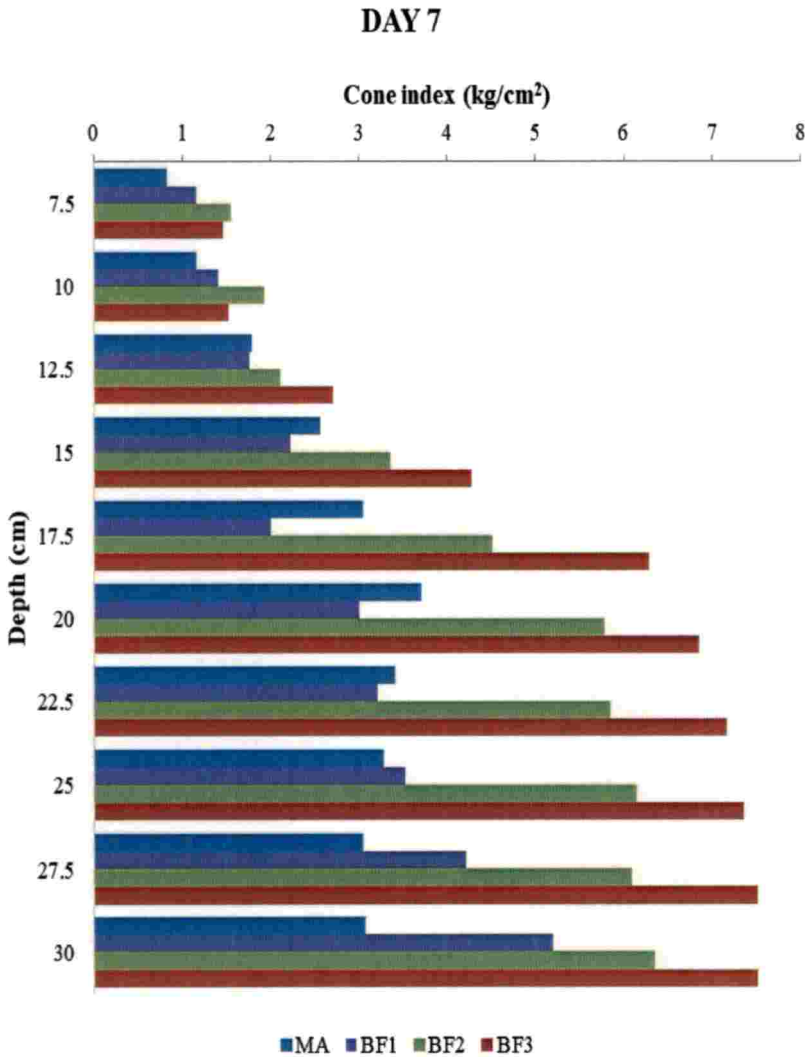

Fig. 4.16 Variation of cone index with depth, on Day 7, in different types of bunds formed

166

The consecutive relative changes in cone index of the different bunds formed at Pullazhi *kole* up to seven days, measured as the relative change in cone index from first day to third day and third day to seventh day are presented in Tables 4.19 to 4.28.

Variations in cone indices were observed as the time elapsed. Increased resistance was offered by the soil in the bund to the penetrometer, as the depth increased. Differential responses, due to the interaction of the different methods of the bund formation over the period of observation, were observed from a depth of 12.5 cm onwards. This indicated that there was a significant variation in the strength of the bund in all processes of bund formation.

Table 4.19 Consecutive relative changes in cone index ( $\text{kg cm}^{-2}$ ) of bunds formed at Pullazhi by various methods at 7.5 cm depth

Change in cone index	Type of bund formation				Mean across different bund types
	Manual	Mechanical – BF3	Mechanical – BF2	Mechanical – BF1	
Change in cone index from D1 to D3	65.56 (7.98)	69.88 (7.36)	44.71 (5.85)	55.43 (6.42)	58.90 (6.90)
Change in cone index from D3 to D7	174.93 (12.15)	125.70 (10.75)	157.43 (12.31)	81.89 (8.60)	134.99 (10.95)
<b>Mean change in cone index</b>	120.24 (10.06)	97.79 (9.05)	101.07 (9.08)	68.66 (7.51)	<b>CD1 – 2.53</b> <b>CD2 – NS</b> <b>CD3 – NS</b>

(figures in parentheses are square root transformed values)

NS= Not significant

CD1 = CD for comparison of changes in cone indices from day 1 to day 3 with changes from day 3 to day 7

CD2 = CD for comparison of cone indices under the different types of bund formation

CD3 = CD for interaction

Table 4.20 Consecutive relative changes in cone index ( $\text{kg cm}^{-2}$ ) of bunds formed at Pullazhi by various methods at 10.0 cm depth

Change in cone index	Type of bund formation				Mean across different bund types
	Manual	Mechanical – BF3	Mechanical – BF2	Mechanical – BF1	
Change in cone index from D1 to D3	68.31 (9.93)	43.37 (8.60)	27.75 (7.26)	25.46 (6.45)	41.22 (8.06)
Change in cone index from D3 to D7	174.92 (13.95)	125.58 (12.18)	119.32 (12.18)	79.95 (10.26)	124.94 (12.14)
<b>Mean change in cone index</b>	121.62 (11.94)	84.48 (10.39)	73.54 (9.72)	52.71 (8.36)	<b>CD1 – 2.07</b> <b>CD2 – NS</b> <b>CD3 – NS</b>

(figures in parentheses are square root transformed values)

NS= Not significant

CD1 = CD for comparison of changes in cone indices from day 1 to day 3 with changes from day 3 to day 7

CD2 = CD for comparison of cone indices under the different types of bund formation

CD3 = CD for interaction

Table 4.21 Consecutive relative changes in cone index ( $\text{kg cm}^{-2}$ ) of bunds formed at Pullazhi by various methods at 12.5 cm depth

Change in cone index	Type of bund formation				Mean across different bund types
	Manual	Mechanical – BF3	Mechanical – BF2	Mechanical – BF1	
Change in cone index from D1 to D3	44.67 (9.32)	70.38 (10.36)	28.55 (8.22)	-3.27 (5.69)	35.08 (8.40)
Change in cone index from D3 to D7	342.72 (19.52)	57.37 (9.46)	45.97 (9.41)	109.75 (12.18)	138.95 (12.64)
<b>Mean change in cone index</b>	193.70 (14.42)	63.87 (9.91)	37.26 (8.81)	53.24 (8.93)	<b>CD1 - 1.90</b> <b>CD2 – 2.68</b> <b>CD3 – 3.79</b>

(figures in parentheses are square root transformed values)

NS= Not significant

CD1 = CD for comparison of changes in cone indices from day 1 to day 3 with changes from day 3 to day 7

CD2 = CD for comparison of cone indices under the different types of bund formation

CD3 = CD for interaction



Table 4.22 Consecutive relative changes in cone index (kg cm<sup>-2</sup>) of bunds formed at Pullazhi by various methods at 15.0 cm depth

Change in cone index	Type of bund formation				Mean across different bund types
	Manual	Mechanical – BF3	Mechanical – BF2	Mechanical – BF1	
Change in cone index from D1 to D3	40.57 (9.76)	29.51 (9.16)	2.95 (6.34)	-20.05 (5.88)	13.25 (7.78)
Change in cone index from D3 to D7	478.77 (22.53)	36.76 (9.57)	110.58 (12.75)	156.46 (13.96)	195.64 (14.70)
<b>Mean change in cone index</b>	259.67 (16.14)	33.13 (9.36)	56.76 (9.54)	68.21 (9.92)	<b>CD1 – 2.19</b> <b>CD2 – 3.10</b> <b>CD3 – 4.39</b>

(figures in parentheses are square root transformed values)

NS= Not significant

CD1 = CD for comparison of changes in cone indices from day 1 to day 3 with changes from day3 to day 7

CD2 = CD for comparison of cone indices under the different types of bund formation

CD3 = CD for interaction

Table 4.23 Consecutive relative changes in cone index (kg cm<sup>-2</sup>) of bunds formed at Pullazhi by various methods at 17.5 cm depth

Change in cone index	Type of bund formation				Mean across different bund types
	Manual	Mechanical – BF3	Mechanical – BF2	Mechanical – BF1	
Change in cone index from D1 to D3	16.17 (8.30)	17.98 (8.48)	-12.71 (5.25)	-11.75 (6.27)	2.42 (7.07)
Change in cone index from D3 to D7	627.31 (25.08)	32.08 (9.33)	174.26 (14.77)	51.30 (9.80)	221.24 (14.75)
<b>Mean change in cone index</b>	321.74 (16.69)	25.03 (8.91)	80.77 (10.01)	19.77 (8.03)	<b>CD1 – 2.62</b> <b>CD2 – 3.70</b> <b>CD3 – 5.24</b>

(figures in parentheses are square root transformed values)

NS= Not significant

CD1 = CD for comparison of changes in cone indices from day 1 to day 3 with changes from day3 to day 7

CD2 = CD for comparison of cone indices under the different types of bund formation

CD3 = CD for interaction

Table 4.24 Consecutive relative changes in cone index ( $\text{kg cm}^{-2}$ ) of bunds formed at Pullazhi by various methods at 20.0 cm depth

Change in cone index	Type of bund formation				Mean across different bund types
	Manual	Mechanical – BF3	Mechanical – BF2	Mechanical – BF1	
Change in cone index from D1 to D3	19.24 (8.99)	20.62 (9.27)	-21.58 (5.76)	28.72 (9.11)	11.75 (8.28)
Change in cone index from D3 to D7	680.92 (26.39)	7.98 (8.59)	225.57 (16.43)	43.52 (9.60)	239.50 (15.25)
<b>Mean change in cone index</b>	350.08 (17.69)	14.30 (8.93)	101.99 (11.09)	36.12 (9.36)	<b>CD1 – 2.78</b> <b>CD2 – 3.93</b> <b>CD3 – 5.55</b>

(figures in parentheses are square root transformed values)

NS= Not significant

CD1 = CD for comparison of changes in cone indices from day 1 to day 3 with changes from day3 to day 7

CD2 = CD for comparison of cone indices under the different types of bund formation

CD3 = CD for interaction

Table 4.25 Consecutive relative changes in cone index ( $\text{kg cm}^{-2}$ ) of bunds formed at Pullazhi by various methods at 22.5 cm depth

Change in cone index	Type of bund formation				Mean across different bund types
	Manual	Mechanical – BF3	Mechanical – BF2	Mechanical – BF1	
Change in cone index from D1 to D3	-3.68 (7.75)	3.38 (8.43)	-33.86 (4.62)	58.52 (9.74)	6.09 (7.64)
Change in cone index from D3 to D7	491.14 (23.18)	4.50 (8.51)	174.23 (14.99)	20.00 (8.76)	172.47 (13.86)
<b>Mean change in cone index</b>	243.73 (15.47)	3.94 (8.47)	70.19 (9.81)	39.26 (9.25)	<b>CD1 – 2.55</b> <b>CD2 - 3.61</b> <b>CD3 – 5.11</b>

(figures in parentheses are square root transformed values)

NS= Not significant

CD1 = CD for comparison of changes in cone indices from day 1 to day 3 with changes from day3 to day 7

CD2 = CD for comparison of cone indices under the different types of bund formation

CD3 = CD for interaction

Table 4.26 Consecutive relative changes in cone index ( $\text{kg cm}^{-2}$ ) of bunds formed at Pullazhi by various methods at 25.0 cm depth

Change in cone index	Type of bund formation				Mean across different bund types
	Manual	Mechanical – BF3	Mechanical – BF2	Mechanical – BF1	
Change in cone index from D1 to D3	53.57 (10.96)	-3.02 (8.30)	-49.27 (4.71)	834.73 (21.55)	209.00 (11.38)
Change in cone index from D3 to D7	181.10 (15.28)	2.68 (8.64)	126.54 (13.88)	-6.33 (7.29)	76.00 (11.27)
<b>Mean change in cone index</b>	117.34 (13.12)	-0.17 (8.47)	38.63 (9.29)	414.20 (14.42)	<b>CD1 – NS</b> <b>CD2 – NS</b> <b>CD3 – 11.29</b>

(figures in parentheses are square root transformed values)

NS= Not significant

CD1 = CD for comparison of changes in cone indices from day 1 to day 3 with changes from day 3 to day 7

CD2 = CD for comparison of cone indices under the different types of bund formation

CD3 = CD for interaction

Table 4.27 Consecutive relative changes in cone index ( $\text{kg cm}^{-2}$ ) of bunds formed at Pullazhi by various methods at 27.5 cm depth

Change in cone index	Type of bund formation				Mean across different bund types
	Manual	Mechanical – BF3	Mechanical – BF2	Mechanical – BF1	
Change in cone index from D1 to D3	119.32 (13.17)	-2.20 (7.98)	-50.84 (3.51)	1294.15 (29.53)	340.11 (13.55)
Change in cone index from D3 to D7	34.03 (9.23)	1.50 (8.22)	97.11 (12.62)	-1.08 (7.99)	32.89 (9.52)
<b>Mean change in cone index</b>	76.67 (11.20)	-0.35 (8.10)	23.13 (8.07)	646.54 (18.76)	<b>CD1 – NS</b> <b>CD2 – 8.27</b> <b>CD3 – 11.70</b>

(figures in parentheses are square root transformed values)

NS= Not significant

CD1 = CD for comparison of changes in cone indices from day 1 to day 3 with changes from day 3 to day 7

CD2 = CD for comparison of cone indices under the different types of bund formation

CD3 = CD for interaction

Table 4.28 Consecutive relative changes in cone index ( $\text{kg cm}^{-2}$ ) of bunds formed at Pullazhi by various methods at 30.0 cm depth

Change in cone index	Type of bund formation				Mean across different bund types
	Manual	Mechanical – BF3	Mechanical – BF2	Mechanical – BF1	
Change in cone index from D1 to D3	75.97 (11.84)	-1.60 (8.39)	-29.37 (6.52)	60.20 (10.91)	26.30 (9.42)
Change in cone index from D3 to D7	-19.69 (6.51)	0.65 (8.52)	36.58 (10.31)	-11.25 (7.74)	1.57 (8.27)
<b>Mean change in cone index</b>	28.14 (9.18)	-0.47 (8.46)	3.61 (8.42)	24.48 (9.33)	<b>CD1 – NS</b> <b>CD2 – NS</b> <b>CD3 – 2.98</b>

(figures in parentheses are square root transformed values)

NS= Not significant

CD1 = CD for comparison of changes in cone indices from day 1 to day 3 with changes from day 3 to day 7

CD2 = CD for comparison of cone indices under the different types of bund formation

CD3 = CD for interaction

At Pullazhi *kole* fields, power tillers are used for land preparation. Tractors with higher power are found unsuitable to the area as they tend to sink into the soil. The KAMCO TeraTrac was used in the trial to investigate its suitability as a convenient and less drudgerous alternate power source. However, the variability in the strength of the bunds point to a lesser compaction of the bunds which may be due to the inadequate power developed by the power source. Of the mechanical bund strengthening implements used, BF1 and BF2 showed a better performance in terms of strength, measured as cone index.

#### 4.5.4.2 Changes in Cone Index Observed in the Bunds Formed at Ponnani Kole

The performance evaluation of the bund strengthening implements was carried out at Kolothumpadam *kolepadavu* in the Ponnani *kole* as per procedure

132

explained in Section 3.5.2 and Section 3.5.4. Tables 4.29 to 4.32 show the changes in the values of cone in

dex measured down the height of the bund at different intervals using the cone penetrometer at consecutive time intervals.

Table 4.29 Summary of changes in cone index ( $\text{kg cm}^{-2}$ ) at different depths within bund formed mechanically by BF3 at consecutive intervals at Ponnani kole

Sl. No.	Depth (cm)	Cone Index ( $\text{kg cm}^{-2}$ )		
		Day 1	Day 3	Day 7
1	7.50	0.31 <sup>h</sup>	1.10 <sup>g</sup>	3.31 <sup>d</sup>
2	10.00	0.42 <sup>h</sup>	1.47 <sup>g</sup>	3.97 <sup>cd</sup>
3	12.50	0.68 <sup>gh</sup>	2.00 <sup>fg</sup>	3.47 <sup>cd</sup>
4	15.00	1.08 <sup>fg</sup>	2.62 <sup>ef</sup>	3.31 <sup>d</sup>
5	17.50	1.38 <sup>ef</sup>	3.31 <sup>de</sup>	3.56 <sup>cd</sup>
6	20.00	1.72 <sup>de</sup>	3.80 <sup>cd</sup>	4.20 <sup>cd</sup>
7	22.50	2.09 <sup>d</sup>	3.98 <sup>bcd</sup>	4.54 <sup>bc</sup>
8	25.00	2.76 <sup>c</sup>	4.48 <sup>bc</sup>	5.40 <sup>ab</sup>
9	27.50	3.42 <sup>b</sup>	4.93 <sup>ab</sup>	5.56 <sup>ab</sup>
10	30.00	4.12 <sup>a</sup>	5.53 <sup>a</sup>	6.37 <sup>a</sup>
	CD	0.45	0.92	1.03

Table 4.30 Summary of changes in cone index ( $\text{kg cm}^{-2}$ ) at different depths within bund formed mechanically by BF2 at consecutive intervals at Ponnani kole

Sl. No.	Depth (cm)	Cone Index ( $\text{kg cm}^{-2}$ )		
		Day 1	Day 3	Day 7
1	7.50	0.23 <sup>e</sup>	0.94 <sup>h</sup>	2.17 <sup>f</sup>
2	10.00	0.29 <sup>e</sup>	1.36 <sup>g</sup>	2.45 <sup>ef</sup>
3	12.50	0.34 <sup>e</sup>	1.90 <sup>f</sup>	2.74 <sup>ef</sup>
4	15.00	0.71 <sup>de</sup>	2.23 <sup>ef</sup>	3.16 <sup>de</sup>
5	17.50	0.85 <sup>de</sup>	2.62 <sup>de</sup>	3.55 <sup>cd</sup>
6	20.00	1.33 <sup>cb</sup>	2.82 <sup>cd</sup>	3.98 <sup>bc</sup>
7	22.50	1.90 <sup>c</sup>	3.10 <sup>c</sup>	4.37 <sup>b</sup>
8	25.00	3.17 <sup>b</sup>	3.69 <sup>b</sup>	5.14 <sup>a</sup>
9	27.50	3.38 <sup>b</sup>	4.04 <sup>b</sup>	5.48 <sup>a</sup>
10	30.00	4.49 <sup>a</sup>	4.69 <sup>a</sup>	5.55 <sup>a</sup>
	CD	0.81	0.40	0.74

Table 4.31 Summary of changes in cone index ( $\text{kg cm}^{-2}$ ) at different depths within bund formed mechanically by BF4 at consecutive intervals at Ponnani *kole*

Sl. No.	Depth (cm)	Cone Index ( $\text{kg cm}^{-2}$ )		
		Day 1	Day 3	Day 7
1	7.50	0.43 <sup>g</sup>	1.30 <sup>f</sup>	3.58 <sup>def</sup>
2	10.00	0.54 <sup>g</sup>	1.61 <sup>ef</sup>	3.52 <sup>def</sup>
3	12.50	0.88 <sup>fg</sup>	1.86 <sup>def</sup>	2.57 <sup>f</sup>
4	15.00	1.24 <sup>ef</sup>	1.93 <sup>def</sup>	2.79 <sup>f</sup>
5	17.50	1.71 <sup>de</sup>	2.32 <sup>cde</sup>	3.42 <sup>ef</sup>
6	20.00	1.93 <sup>cd</sup>	2.63 <sup>cd</sup>	4.23 <sup>cde</sup>
7	22.50	2.41 <sup>c</sup>	3.14 <sup>bc</sup>	4.76 <sup>bcd</sup>
8	25.00	3.08 <sup>b</sup>	3.56 <sup>b</sup>	5.13 <sup>abc</sup>
9	27.50	3.69 <sup>ab</sup>	3.82 <sup>b</sup>	5.72 <sup>ab</sup>
10	30.00	4.11 <sup>a</sup>	4.82 <sup>a</sup>	6.35 <sup>a</sup>
	CD	0.62	0.85	1.18

Table 4.32 Summary of changes in cone index ( $\text{kg cm}^{-2}$ ) at different depths within bund formed manually at consecutive intervals at Ponnani *kole*

Sl. No.	Depth (cm)	Cone Index ( $\text{kg cm}^{-2}$ )		
		Day 1	Day 3	Day 7
1	7.50	0.28 <sup>f</sup>	1.41 <sup>c</sup>	3.31 <sup>cde</sup>
2	10.00	0.55 <sup>ef</sup>	1.64 <sup>c</sup>	3.45 <sup>cde</sup>
3	12.50	0.66 <sup>def</sup>	1.47 <sup>c</sup>	2.54 <sup>e</sup>
4	15.00	0.77 <sup>def</sup>	1.49 <sup>c</sup>	2.54 <sup>e</sup>
5	17.50	0.94 <sup>de</sup>	1.59 <sup>c</sup>	2.88 <sup>de</sup>
6	20.00	1.14 <sup>d</sup>	2.00 <sup>bc</sup>	3.49 <sup>cde</sup>
7	22.50	2.04 <sup>c</sup>	2.00 <sup>bc</sup>	4.29 <sup>bc</sup>
8	25.00	2.80 <sup>b</sup>	2.29 <sup>bc</sup>	3.83 <sup>cd</sup>
9	27.50	3.11 <sup>b</sup>	2.90 <sup>ab</sup>	5.11 <sup>ab</sup>
10	30.00	3.83 <sup>a</sup>	3.69 <sup>a</sup>	5.69 <sup>a</sup>
	CD	0.46	0.85	1.01

The values of the cone index increased, along the depth of the bunds and at the time intervals considered, in all cases. On the first day, the values increased

from  $0.31 \text{ kg cm}^{-2}$  at the depth of 7.5 cm from the top of the bund, to  $4.12 \text{ kg cm}^{-2}$  at the depth of 30.0 cm from the top, in case of the bunds formed using BF3. For the bunds formed by BF2, these values were from 0.23 to  $4.49 \text{ kg cm}^{-2}$  while for BF4 these ranged from 0.43 to  $4.11 \text{ kg cm}^{-2}$ . Initially, the bund formation using BF4 tended to impart more strength to the top layers of the formed bund, due to the increased force exerted on the top of the bund on account of the two passes, where the second pass over the bund is of a reduced area.

The same trend was observed on the third and the seventh day after bund formation in case of the mechanically formed bunds using the different types of bund strengthening implements. On the third day, the values ranged from 1.10, 0.94 and  $1.30 \text{ kg cm}^{-2}$  at depth 7.5 cm to 5.53, 4.69 and  $4.82 \text{ kg cm}^{-2}$  at 30.0 cm in case of bunds formed by BF3, BF2 and BF4 respectively. On the seventh day, these increased to 3.31, 2.17 and  $3.58 \text{ kg cm}^{-2}$  at 7.5 cm to 6.37, 5.55 and  $6.35 \text{ kg cm}^{-2}$  at 30.0 cm, in the previous order. In case of the manual bunds, the values increased from  $0.28 \text{ kg cm}^{-2}$  at 7.5 cm depth to  $3.83 \text{ kg cm}^{-2}$  at 30.0 cm depth on the first day. These bunds were thus less strong in comparison to the mechanically formed ones on the day of formation. But with the progression of time, the strength of the top layers increased and the values of the cone index of manually formed bunds at 7.5 cm and 10.0 cm from the top of the bund were very near the values of the bund formed mechanically using BF3, by the seventh day. However, as depth increased these values showed a comparative decrease, which may be due to the lesser compaction offered to the bunds in the process of manual bund formation.

The changes in cone index values at incremental depths over consecutive time intervals for the different types of bunds formed at Ponnani *kole* are plotted in Fig. 4.17.

The variation in the cone index values with depth at consecutive time intervals, observed in the different types of bunds formed, are depicted in Fig. 4.18 to 4.20. The values are provided in Appendix V.

Change in cone index ( $\text{kg cm}^{-2}$ ) at different depths in manually formed bund

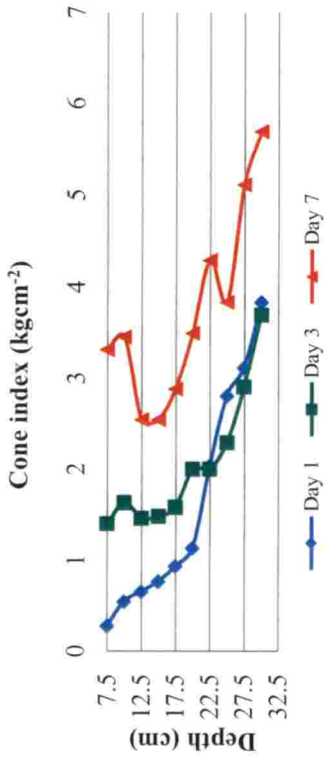

Change in cone index ( $\text{kg cm}^{-2}$ ) at different depths in bund formed using BF2

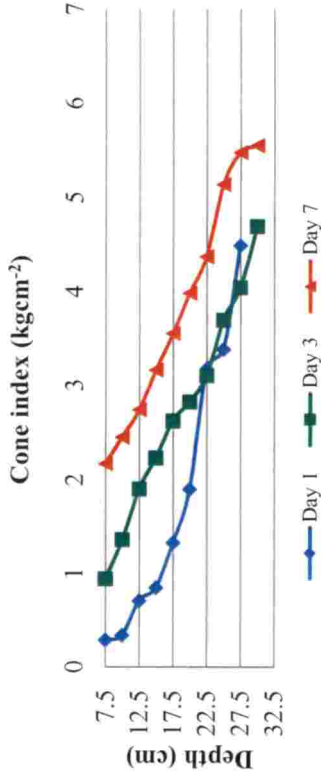

Change in cone index ( $\text{kg cm}^{-2}$ ) at different depths in bund formed using BF3

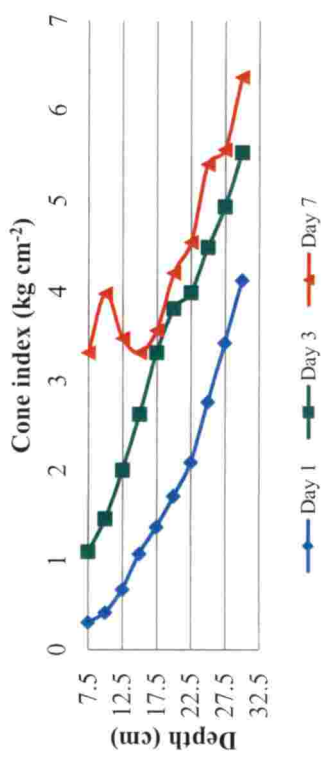

Change in cone index ( $\text{kg cm}^{-2}$ ) at different depths in bund formed using BF4

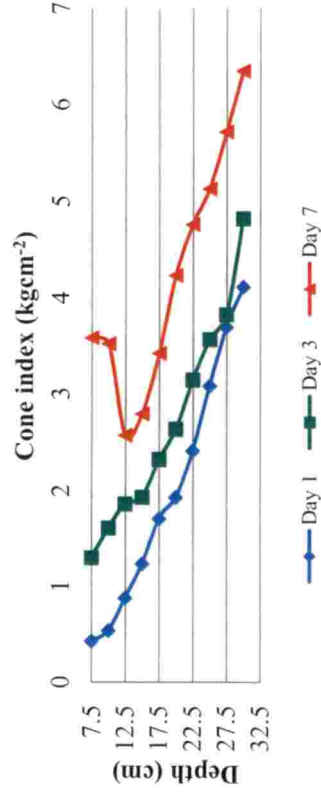

Fig. 4.17 Changes in cone index ( $\text{kg cm}^{-2}$ ) at incremental depths over consecutive time intervals for different types of bunds formed at Ponnani kole

981



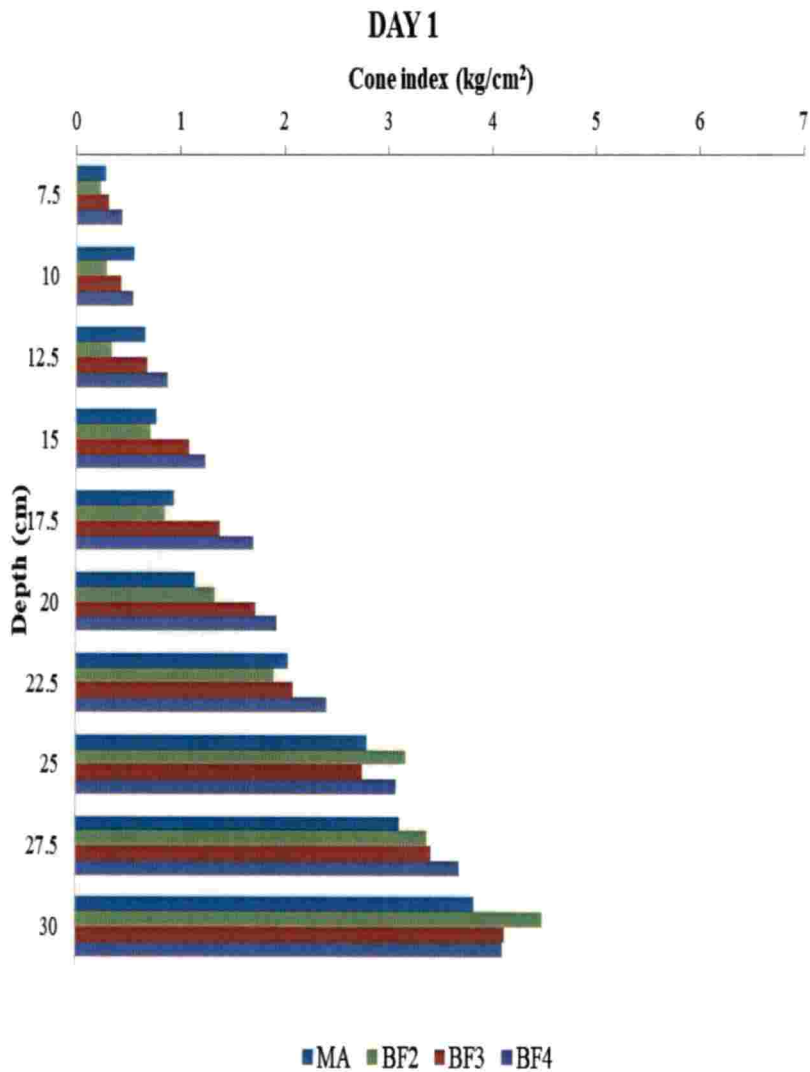

Fig. 4.18 Variation of cone index with depth at consecutive intervals, on Day 1, in different types of bunds at Ponnani *kole*

The values of cone index increased with depth in all the bunds formed. Initially, the bunds formed by BF3 and BF4 showed a considerably higher value when compared to the bunds formed by BF2 and the manually formed bunds. The observations taken at the third day also showed a similar trend but the values of resistance increased. On the seventh day after bund formation it was observed that the cone index values observed at depths of 7.5 and 10.0 cm, i.e., the top

127

layers of the bund, offered increased resistance to the cone penetrometer as the top layers dried.

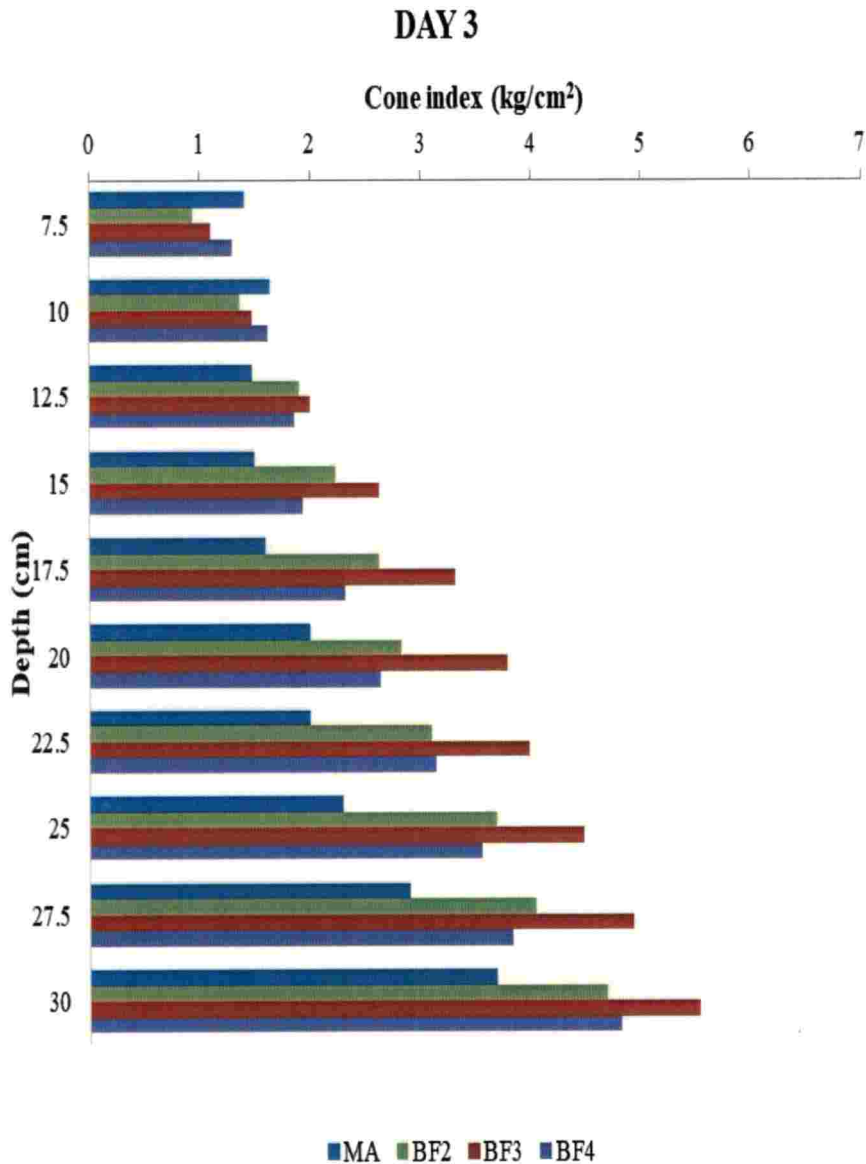

Fig. 4.19 Variation of cone index with depth at consecutive intervals, on Day 3, in different types of bunds at Ponnani *kole*

After the initial spike, the same trend, as observed on the previous days of observation, was seen, with higher values of cone index, indicating that the strength of the soil in the bund increased with passage of time.

178

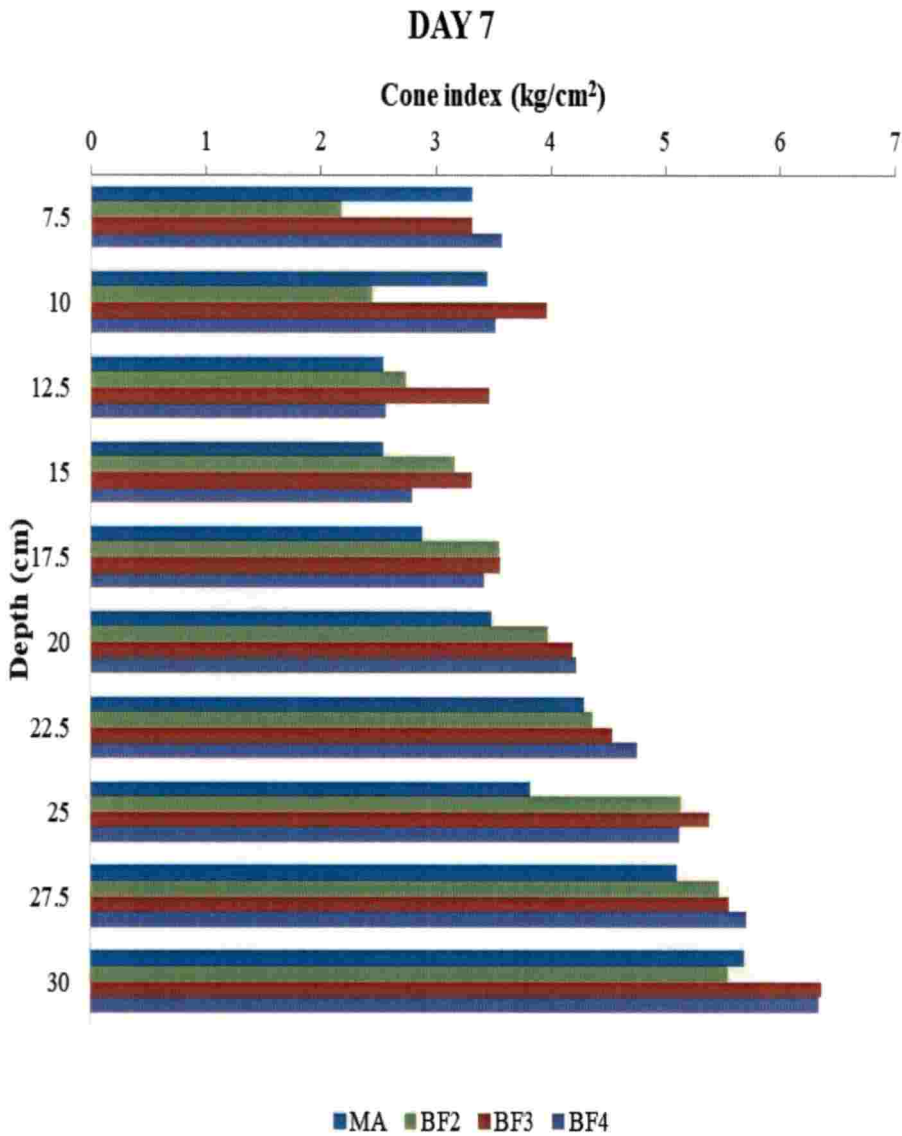

Fig. 4.20 Variation of cone index with depth at consecutive intervals, on Day 7, in different types of bunds at Ponnani *kole*

The consecutive relative changes of cone index at Ponnani *kole* up to seven days, measured as the relative change in cone index from first day to third day and third day to seventh day after bund formation are presented in Tables 4.33 to 4.42.

129

Table 4.33 Consecutive relative changes in cone index ( $\text{kg cm}^{-2}$ ) of bunds formed at Ponnani *kole* by various methods at 7.5 cm depth

Change in cone index	Type of bund formation				Mean across different bund types
	Manual	Mechanical – BF3	Mechanical – BF2	Mechanical – BF4	
Change in cone index from Day 1 to Day 3	425.24 (20.45)	275.61 (16.20)	324.55 (17.83)	223.89 (14.71)	312.32 (17.30)
Change in cone index from Day 3 to Day 7	139.39 (11.60)	223.69 (14.37)	134.17 (11.26)	184.16 (13.04)	170.35 (12.57)
<b>Mean change in cone index</b>	282.32 (16.03)	249.65 (15.28)	229.36 (14.54)	204.0 2(13.88)	<b>CD1- 2.32</b> <b>CD2- NS</b> <b>CD3- NS</b>

Table 4.34 Consecutive relative changes in cone index ( $\text{kg cm}^{-2}$ ) of bunds formed at Ponnani *kole* by various methods at 10.0 cm depth

Change in cone index	Type of bund formation				Mean across different bund types
	Manual	Mechanical – BF3	Mechanical – BF2	Mechanical – BF4	
Change in cone index from Day 1 to Day 3	198.89 (14.05)	262.33 (15.54)	372.31 (19.19)	239.429 (14.72)	268.238 (15.95)
Change in cone index from Day 3 to Day 7	118.54 (10.60)	187.85 (13.29)	87.475 (8.37)	139.547 (10.93)	133.353 (10.80)
<b>Mean change in cone index</b>	158.71 (12.33)	225.09 (14.56)	229.892 (13.78)	189.488 (12.82)	<b>CD1 - 2.54</b> <b>CD2 – NS</b> <b>CD3 – NS</b>

(figures in parentheses are square root transformed values)

NS= Not significant

CD1 = CD for comparison of change in cone indices from day 1 to day 3 with changes from day 3 to day 7

CD2 = CD for comparison of cone indices under the different types of bund formation

CD3 = CD for interaction

Table 4.35 Consecutive relative changes in cone index ( $\text{kg cm}^{-2}$ ) of bunds formed at Ponnani *kole* by various methods at 12.5 cm depth

Change in cone index	Type of bund formation				Mean across different bund types
	Manual	Mechanical – BF3	Mechanical – BF2	Mechanical – BF4	
Change in cone index from Day 1 to Day 3	122.78 (12.03)	216.89 (14.96)	473.96 (22.17)	143.57 (12.08)	239.30 (15.31)
Change in cone index from Day 3 to Day 7	74.57 (9.64)	84.53 (10.07)	46.76 (8.19)	48.49 (7.06)	63.59 (8.74)
<b>Mean change in cone index</b>	98.68 (10.39)	150.71 (12.51)	260.36 (15.18)	96.03 (9.57)	<b>CD1 - 2.26</b> <b>CD2 - 3.20</b> <b>CD3 - 4.53</b>

Table 4.36 Consecutive relative changes in cone index ( $\text{kg cm}^{-2}$ ) of bunds formed at Ponnani *kole* by various methods at 15.0 cm depth

Change in cone index	Type of bund formation				Mean across different bund types
	Manual	Mechanical – BF3	Mechanical – BF2	Mechanical – BF4	
Change in cone index from Day 1 to Day 3	93.49 (10.52)	163.79 (12.93)	270.55 (16.25)	73.57 (8.53)	150.35 (12.06)
Change in cone index from Day 3 to Day 7	72.33 (9.37)	41.53 (6.29)	47.41 (7.95)	68.22 (7.86)	57.37 (7.87)
<b>Mean change in cone index</b>	82.91 (9.95)	102.66 (9.61)	158.98 (12.10)	70.90 (8.19)	<b>CD1 - 2.75</b> <b>CD2 - NS</b> <b>CD3 - NS</b>

(figures in parentheses are square root transformed values)

NS= Not significant

CD1 = CD for comparison of change in cone indices from day 1 to day 3 with changes from day 3 to day 7

CD2 = CD for comparison of cone indices under the different types of bund formation

CD3 = CD for interaction

Table 4.37 Consecutive relative changes in cone index ( $\text{kg cm}^{-2}$ ) of bunds formed at Ponnani *kole* by various methods at 17.5 cm depth

Change in cone index	Type of bund formation				Mean across different bund types
	Manual	Mechanical – BF3	Mechanical – BF2	Mechanical – BF4	
Change in cone index from Day 1 to Day 3	69.26 (10.18)	142.12 (13.37)	251.48 (16.48)	44.55 (7.92)	126.85 (11.99)
Change in cone index from Day 3 to Day 7	85.16 (10.97)	5.85 (6.33)	36.54 (8.55)	98.77 (9.80)	56.58 (8.91)
<b>Mean change in cone index</b>	77.21 (10.58)	73.98 (9.85)	144.00 (12.51)	71.66 (8.86)	<b>CD1 - 2.34</b> <b>CD2 - NS</b> <b>CD3 - 4.67</b>

Table 4.38 Consecutive relative changes in cone index ( $\text{kg cm}^{-2}$ ) of bunds formed at Ponnani *kole* by various methods at 20.0 cm depth

Change in cone index	Type of bund formation				Mean across different bund types
	Manual	Mechanical – BF3	Mechanical – BF2	Mechanical – BF4	
Change in cone index from Day 1 to Day 3	76.13 (10.44)	126.99 (12.69)	157.56 (13.27)	44.79 (8.06)	101.37 (11.12)
Change in cone index from Day 3 to Day 7	78.03 (10.68)	10.24 (6.82)	41.91 (8.83)	94.14 (10.16)	56.08 (9.12)
<b>Mean change in cone index</b>	77.08 (10.56)	68.62 (9.75)	99.73 (11.05)	69.47 (9.11)	<b>CD1 - NS</b> <b>CD2 - NS</b> <b>CD3 - 4.37</b>

(figures in parentheses are square root transformed values)

NS= Not significant

CD1 = CD for comparison of change in cone indices from day 1 to day 3 with changes from day 3 to day 7

CD2 = CD for comparison of cone indices under the different types of bund formation

CD3 = CD for interaction

Table 4.39 Consecutive relative changes in cone index ( $\text{kg cm}^{-2}$ ) of bunds formed at Ponnani *kole* by various methods at 22.5 cm depth

Change in cone index	Type of bund formation				Mean across different bund types
	Manual	Mechanical – BF3	Mechanical – BF2	Mechanical – BF4	
Change in cone index from Day 1 to Day 3	2.26 (6.43)	93.27 (11.82)	97.01 (11.42)	45.09 (8.64)	59.41 (9.58)
Change in cone index from Day 3 to Day 7	132.04 (13.17)	16.89 (7.97)	41.97 (9.46)	73.68 (10.42)	66.13 (10.25)
<b>Mean change in cone index</b>	67.15 (9.80)	55.08 (9.89)	69.49 (10.44)	59.35 (9.53)	<b>CD1 - NS CD2 - NS CD3 - 4.13</b>

Table 4.40 Consecutive relative changes in cone index ( $\text{kg cm}^{-2}$ ) of bunds formed at Ponnani *kole* by various methods at 25.0 cm depth

Change in cone index	Type of bund formation				Mean across different bund types
	Manual	Mechanical – BF3	Mechanical – BF2	Mechanical – BF4	
Change in cone index from Day 1 to Day 3	-6.28 (6.56)	61.19 (11.21)	47.94 (9.96)	20.63 (9.04)	30.87 (9.19)
Change in cone index from Day 3 to Day 7	80.88 (11.80)	23.58 (9.38)	41.08 (10.26)	51.93 (10.63)	49.37 (10.52)
<b>Mean change in cone index</b>	37.30 (9.18)	42.38 (10.29)	44.51 (10.11)	36.28 (9.84)	<b>CD1 - NS CD2 - NS CD3 - 3.36</b>

(figures in parentheses are square root transformed values)

NS= Not significant

CD1 = CD for comparison of change in cone indices from day 1 to day 3 with changes from day 3 to day 7

CD2 = CD for comparison of cone indices under the different types of bund formation

CD3 = CD for interaction

Table 4.41 Consecutive relative changes in cone index ( $\text{kg cm}^{-2}$ ) of bunds formed at Ponnani *kole* by various methods at 27.5 cm depth

Change in cone index	Type of bund formation			Mean across different bund types	
	Manual	Mechanical – BF3	Mechanical – BF2		Mechanical – BF4
Change in cone index from Day 1 to Day 3	-4.78 (5.23)	44.20 (9.33)	34.07 (8.45)	5.73 (6.84)	19.81 (7.46)
Change in cone index from Day 3 to Day 7	99.37 (11.49)	14.39 (7.57)	35.65 (8.89)	54.66 (9.78)	51.04 (9.43)
<b>Mean change in cone index</b>	47.30 (8.36)	29.29 (8.44)	34.86 (8.67)	30.20 (8.31)	<b>CD1 – 1.60</b> <b>CD2 – NS</b> <b>CD3 – 3.20</b>

Table 4.42 Consecutive relative changes in cone index ( $\text{kg cm}^{-2}$ ) of bunds formed at Ponnani *kole* by various methods at 30.0 cm depth

Change in cone index	Type of bund formation			Mean across different bund types	
	Manual	Mechanical – BF3	Mechanical – BF2		Mechanical – BF4
Change in cone index from Day 1 to Day 3	-1.15 (5.63)	37.81 (8.73)	4.91 (6.82)	18.16 (7.70)	14.93 (7.22)
Change in cone index from Day 3 to Day 7	66.78 (10.10)	16.90 (7.63)	17.83 (7.62)	33.02 (8.58)	33.63 (8.48)
<b>Mean change in cone index</b>	32.82 (7.86)	27.36 (8.18)	11.37 (7.22)	25.59 (8.14)	<b>CD1 – 1.27</b> <b>CD2 – NS</b> <b>CD3 – 2.53</b>

(figures in parentheses are square root transformed values)

NS= Not significant

CD1 = CD for comparison of change in cone indices from day 1 to day 3 with changes from day 3 to day 7

CD2 = CD for comparison of cone indices under the different types of bund formation

CD3 = CD for interaction



#### 4.5.4.3 Changes in Cone Index Observed in the Bunds Formed at Tavanur

In Tavanur, the manually formed bunds are large in size and the mechanical models developed and tested in the trials were only able to draw new bunds in fields rather than strengthening the pre-existing bunds, as in the case of the other two locations. However the trials were carried out to determine the suitability of the mechanical bund strengthening implements to form new bunds in these soil conditions.

The changes occurring in the values of cone index measured along the depth of the bunds formed by the different processes using NH 3230 are summarised in Tables 4.43 to 4.46. Table 4.47 shows these variations in manually formed bunds while the change occurring in bunds formed using the KTT as power source are shown in Tables 4.48 and 4.49. Only BF2 and BF1 were used with the KTT.

The general trend was of increase in the cone index values as the depth increased in all methods of bund formation, using both the power sources, viz., NH 3230 and KTT. These values were also seen to generally increase at consecutive time intervals for the same depths.

Table 4.43 shows the variation in cone index along the depth of bunds, in case of the bunds formed using BF3, over the time period of observation. It was observed that the values of cone index varied from  $0.40 \text{ kg cm}^{-2}$  at a depth of 7.5 cm from the top of the formed bund to  $6.62 \text{ kg cm}^{-2}$  at a depth of 30 cm. These values increased to  $0.48 \text{ kg cm}^{-2}$  and  $1.52 \text{ kg cm}^{-2}$  at depth of 7.5 cm to  $6.74 \text{ kg cm}^{-2}$  and  $7.13 \text{ kg cm}^{-2}$  at depth of 30 cm on the third and seventh day respectively.

Table 4.43 Summary of changes in cone index ( $\text{kg cm}^{-2}$ ) within bund formed using BF3-NH3230 at consecutive intervals at Tavanur paddy fields

Sl. No.	Depth (cm)	Cone index ( $\text{kg cm}^{-2}$ )		
		Day 1	Day 3	Day 7
1	7.50	0.40 <sup>f</sup>	0.48 <sup>f</sup>	1.52 <sup>d</sup>
2	10.00	0.42 <sup>f</sup>	0.62 <sup>ef</sup>	1.58 <sup>d</sup>
3	12.50	0.54 <sup>f</sup>	0.79 <sup>ef</sup>	1.42 <sup>d</sup>
4	15.00	0.69 <sup>f</sup>	0.86 <sup>ef</sup>	1.53 <sup>d</sup>
5	17.50	0.83 <sup>ef</sup>	1.19 <sup>de</sup>	1.58 <sup>d</sup>
6	20.00	1.27 <sup>c</sup>	1.53 <sup>d</sup>	2.07 <sup>d</sup>
7	22.50	2.35 <sup>d</sup>	3.16 <sup>c</sup>	4.01 <sup>c</sup>
8	25.00	3.79 <sup>c</sup>	4.66 <sup>b</sup>	5.05 <sup>b</sup>
9	27.50	5.07 <sup>b</sup>	6.17 <sup>a</sup>	6.55 <sup>a</sup>
10	30.00	6.62 <sup>a</sup>	6.74 <sup>a</sup>	7.13 <sup>a</sup>
	CD	0.47	0.62	0.62

For the bunds formed using BF2, these values ranged from 0.26 to 0.49 to 1.04  $\text{kg cm}^{-2}$  at the depth of 7.5 cm and from 7.38 to 7.30 to 7.64  $\text{kg cm}^{-2}$  at the depth of 30 cm from day one to day three to day seven respectively, as shown in Table 4.44.

Table 4.44 Summary of changes in cone index ( $\text{kg cm}^{-2}$ ) within bund formed using BF2-NH3230 at consecutive intervals at Tavanur paddy fields

Sl. No.	Depth (cm)	Cone index ( $\text{kg cm}^{-2}$ )		
		Day 1	Day 3	Day 7
1	7.50	0.26 <sup>g</sup>	0.49 <sup>h</sup>	1.04 <sup>g</sup>
2	10.00	0.28 <sup>g</sup>	0.52 <sup>h</sup>	1.04 <sup>g</sup>
3	12.50	0.34 <sup>g</sup>	0.57 <sup>gh</sup>	1.13 <sup>g</sup>
4	15.00	0.46 <sup>g</sup>	0.91 <sup>g</sup>	1.42 <sup>g</sup>
5	17.50	1.38 <sup>f</sup>	2.26 <sup>f</sup>	2.80 <sup>f</sup>
6	20.00	3.25 <sup>e</sup>	4.17 <sup>e</sup>	4.68 <sup>e</sup>
7	22.50	4.34 <sup>d</sup>	5.14 <sup>d</sup>	5.69 <sup>d</sup>
8	25.00	5.50 <sup>c</sup>	6.14 <sup>c</sup>	6.65 <sup>c</sup>
9	27.50	6.63 <sup>b</sup>	6.65 <sup>b</sup>	7.07 <sup>b</sup>
10	30.00	7.38 <sup>a</sup>	7.30 <sup>a</sup>	7.64 <sup>a</sup>
	CD	0.55	0.37	0.42

Table 4.45 shows the variation in cone indices in bunds formed using BF1. The values ranged from 0.24 to 0.42 to 0.88 kg cm<sup>-2</sup> at a depth of 7.5 cm and 6.01 to 6.23 to 6.09 kg cm<sup>-2</sup> at a depth of 30 cm for the aforesaid time ranges.

Table 4.45 Summary of changes in cone index (kg cm<sup>-2</sup>) within bund formed using BF1-NH3230 at consecutive intervals at Tavanur paddy fields

Sl. No.	Depth (cm)	Cone index (kg cm <sup>-2</sup> )		
		Day 1	Day 3	Day 7
1	7.50	0.24 <sup>g</sup>	0.42 <sup>h</sup>	0.88 <sup>g</sup>
2	10.00	0.24 <sup>g</sup>	0.46 <sup>h</sup>	1.00 <sup>g</sup>
3	12.50	0.32 <sup>g</sup>	0.59 <sup>gh</sup>	1.11 <sup>fg</sup>
4	15.00	0.46 <sup>g</sup>	0.82 <sup>g</sup>	1.33 <sup>f</sup>
5	17.50	1.16 <sup>f</sup>	1.80 <sup>f</sup>	2.59 <sup>e</sup>
6	20.00	2.54 <sup>c</sup>	3.00 <sup>e</sup>	3.92 <sup>d</sup>
7	22.50	3.39 <sup>d</sup>	4.24 <sup>d</sup>	4.21 <sup>d</sup>
8	25.00	4.37 <sup>c</sup>	4.91 <sup>c</sup>	5.02 <sup>c</sup>
9	27.50	5.41 <sup>b</sup>	5.52 <sup>b</sup>	5.44 <sup>b</sup>
10	30.00	6.01 <sup>a</sup>	6.23 <sup>a</sup>	6.09 <sup>a</sup>
	CD	0.42	0.32	0.31

In case of BF4, these values averaged at 0.32 to 0.54 to 1.08 kg cm<sup>-2</sup> at a depth of 7.5 cm and 7.52 to 7.75 to 8.15 kg cm<sup>-2</sup> at the depths of 30 cm; for the time intervals under consideration, as shown in Table 4.46.

Table 4.46 Summary of changes in cone index (kg cm<sup>-2</sup>) within bund formed using BF4-NH3230 at consecutive intervals at Tavanur paddy fields

Sl. No.	Depth (cm)	Cone index (kg cm <sup>-2</sup> )		
		Day 1	Day 3	Day 7
1	7.50	0.32 <sup>d</sup>	0.54 <sup>d</sup>	1.08 <sup>d</sup>
2	10.00	0.35 <sup>d</sup>	0.63 <sup>d</sup>	1.10 <sup>d</sup>
3	12.50	0.38 <sup>d</sup>	0.62 <sup>d</sup>	1.16 <sup>d</sup>
4	15.00	0.45 <sup>d</sup>	0.79 <sup>d</sup>	1.25 <sup>d</sup>
5	17.50	0.85 <sup>d</sup>	0.82 <sup>d</sup>	1.36 <sup>d</sup>
6	20.00	1.17 <sup>d</sup>	1.33 <sup>d</sup>	1.79 <sup>d</sup>
7	22.50	2.17 <sup>c</sup>	2.49 <sup>c</sup>	3.04 <sup>c</sup>
8	25.00	5.28 <sup>b</sup>	5.84 <sup>b</sup>	6.31 <sup>b</sup>
9	27.50	7.25 <sup>a</sup>	7.11 <sup>a</sup>	7.66 <sup>a</sup>
10	30.00	7.52 <sup>a</sup>	7.75 <sup>a</sup>	8.15 <sup>a</sup>
	CD	0.81	0.81	0.80

The variation in the cone index along the depth in case of manual bunds is shown in Table 4.47. As expected, the values of cone index were the highest at all depths for the manually formed bunds, with the values ranging from 0.45 kg cm<sup>-2</sup> at depth of 7.5 cm from the top to 5.97 kg cm<sup>-2</sup> at depth of 30.0 cm on the first day. These values changed to 0.93 kg cm<sup>-2</sup> and 7.55 kg cm<sup>-2</sup> on the third day and 1.55 kg cm<sup>-2</sup> to 7.55 kg cm<sup>-2</sup> on the seventh day of observation respectively.

Table 4.47 Summary of changes in cone index (kg cm<sup>-2</sup>) at different depths within bund formed manually at consecutive intervals at Tavanur paddy fields

Sl. No.	Depth (cm)	Cone index (kg cm <sup>-2</sup> )		
		Day 1	Day 3	Day 7
1	7.50	0.45 <sup>g</sup>	0.93 <sup>d</sup>	1.55 <sup>c</sup>
2	10.00	0.55 <sup>g</sup>	1.19 <sup>d</sup>	2.00 <sup>e</sup>
3	12.50	1.04 <sup>f</sup>	1.62 <sup>cd</sup>	2.65 <sup>de</sup>
4	15.00	1.38 <sup>f</sup>	2.69 <sup>bc</sup>	3.86 <sup>cd</sup>
5	17.50	2.29 <sup>e</sup>	3.76 <sup>b</sup>	4.73 <sup>bc</sup>
6	20.00	3.31 <sup>d</sup>	6.18 <sup>a</sup>	6.32 <sup>ab</sup>
7	22.50	4.69 <sup>c</sup>	7.05 <sup>a</sup>	7.53 <sup>a</sup>
8	25.00	5.10 <sup>bc</sup>	7.66 <sup>a</sup>	7.31 <sup>a</sup>
9	27.50	5.55 <sup>ab</sup>	7.41 <sup>a</sup>	8.01 <sup>a</sup>
10	30.00	5.97 <sup>a</sup>	7.55 <sup>a</sup>	7.55 <sup>a</sup>
	CD	0.46	1.33	1.69

When KTT was used as the power source, only the BF2 and BF1 were found suitable in producing a visually satisfactory bund and hence only these were considered for the trials. In this case, while using BF2, the cone index values were observed to vary from 0.35 kg cm<sup>-2</sup> on the first day to 0.49 kg cm<sup>-2</sup> on the seventh day at a depth of 7.5 cm from the top of the bund. These values reached 7.08 kg cm<sup>-2</sup> and 7.83 kg cm<sup>-2</sup> on the first and seventh day respectively at a depth of 30 cm from the top of the bund (Table 4.48).

Table 4.48 Summary of changes in cone index ( $\text{kg cm}^{-2}$ ) within bund formed using BF2-KTT at consecutive intervals at Tavanur paddy fields

Sl. No.	Depth (cm)	Cone index ( $\text{kg cm}^{-2}$ )		
		Day 1	Day 3	Day 7
1	7.50	0.35 <sup>e</sup>	0.35 <sup>e</sup>	0.49 <sup>f</sup>
2	10.00	0.43 <sup>e</sup>	0.43 <sup>e</sup>	0.54 <sup>f</sup>
3	12.50	0.48 <sup>e</sup>	0.51 <sup>e</sup>	0.68 <sup>f</sup>
4	15.00	0.57 <sup>e</sup>	0.68 <sup>e</sup>	0.79 <sup>f</sup>
5	17.50	0.71 <sup>de</sup>	1.73 <sup>d</sup>	1.02 <sup>ef</sup>
6	20.00	1.49 <sup>de</sup>	2.68 <sup>c</sup>	1.80 <sup>de</sup>
7	22.50	1.84 <sup>cd</sup>	3.25 <sup>c</sup>	2.63 <sup>d</sup>
8	25.00	2.69 <sup>c</sup>	5.81 <sup>b</sup>	4.97 <sup>c</sup>
9	27.50	5.28 <sup>b</sup>	7.80 <sup>a</sup>	6.86 <sup>b</sup>
10	30.00	7.08 <sup>a</sup>	8.49 <sup>a</sup>	7.83 <sup>a</sup>
	CD	1.11	0.71	0.91

When BF1 was operated using KTT, the values of cone index observed at a depth of 7.5 cm ranged from 0.31  $\text{kg cm}^{-2}$  at the first day to 0.59  $\text{kg cm}^{-2}$  at the seventh day and at a depth of 30 cm these values ranged from 6.40  $\text{kg cm}^{-2}$  to 7.42  $\text{kg cm}^{-2}$  at the same time intervals (Table 4.49).

Table 4.49 Summary of changes in cone index ( $\text{kg cm}^{-2}$ ) within bund formed using BF1-KTT at consecutive intervals at Tavanur paddy fields

Sl. No.	Depth (cm)	Cone index ( $\text{kg cm}^{-2}$ )		
		Day 1	Day 3	Day 7
1	7.50	0.31 <sup>d</sup>	0.35 <sup>f</sup>	0.59 <sup>i</sup>
2	10.00	0.46 <sup>d</sup>	0.37 <sup>f</sup>	0.77 <sup>hi</sup>
3	12.50	0.54 <sup>d</sup>	0.48 <sup>f</sup>	0.97 <sup>gh</sup>
4	15.00	0.66 <sup>d</sup>	0.54 <sup>f</sup>	1.19 <sup>fg</sup>
5	17.50	0.82 <sup>d</sup>	0.77 <sup>f</sup>	1.39 <sup>f</sup>
6	20.00	1.31 <sup>cd</sup>	1.52 <sup>e</sup>	2.80 <sup>e</sup>
7	22.50	2.01 <sup>c</sup>	3.36 <sup>d</sup>	4.32 <sup>d</sup>
8	25.00	3.73 <sup>b</sup>	6.20 <sup>c</sup>	5.69 <sup>c</sup>
9	27.50	5.45 <sup>a</sup>	7.10 <sup>b</sup>	6.72 <sup>b</sup>
10	30.00	6.40 <sup>a</sup>	7.64 <sup>a</sup>	7.42 <sup>a</sup>
	CD	0.95	0.52	0.36

The changes in cone index values at incremental depths over consecutive time intervals for the different types of bunds formed at Tavanur using NH3230 as power source are plotted below in Fig. 4.21(a) and (b). The changes in bunds formed using KTT as power source are plotted in Fig. 4.22. The variation in the values of cone index at incremental depths for the various types of bunds formed using NH 3230 are shown in Fig. 4.23 to 4.25. The values are presented in Appendix V.

The resistance offered by the manually formed bunds was generally observed to be high, as compared to the mechanically formed bunds, in all cases. On the day of formation of the bunds, however, it was seen that at depths of 20 cm and 22.5 cm, BF2 also performed on par with the manually formed bunds. When the cone index values were measured at the depth of 25 cm, it was seen that BF2 and BF4 also created bunds on par with the manual bunds. On further increase of depth, it was observed that the penetration resistance offered by the mechanically formed bunds using BF2 and BF4 showed greater and on par values. The manual bunds and the bunds formed by BF3 and BF1 showed similar behaviour on this property. The top layers of the manually formed bunds offered greater penetration resistance on the third day after bund formation. However, at the last depths of measurement, it was observed that the cone indices of almost all the types of bunds were on par.

By the seventh day, the values of cone indices increased in all cases. The manual bund continues to show increased resistance to penetration. The mechanical bund strengthening implements showed on par performance at the initial depths and towards the latter depths of measurement, it was observed that the performance of BF4 of mechanical models gave the highest cone index.

Change in cone index at different depths in manually formed bunds

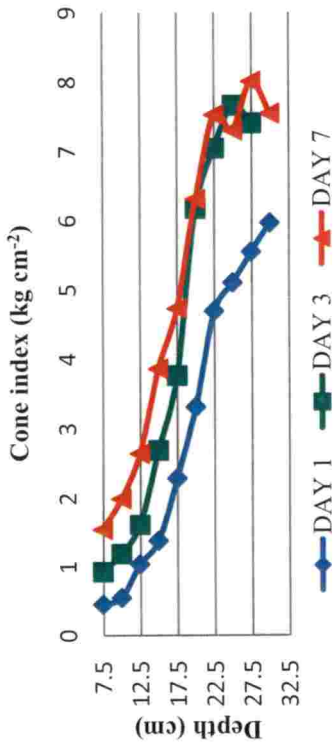

Change in cone index at different depths in bunds formed using BF1 - NH3230

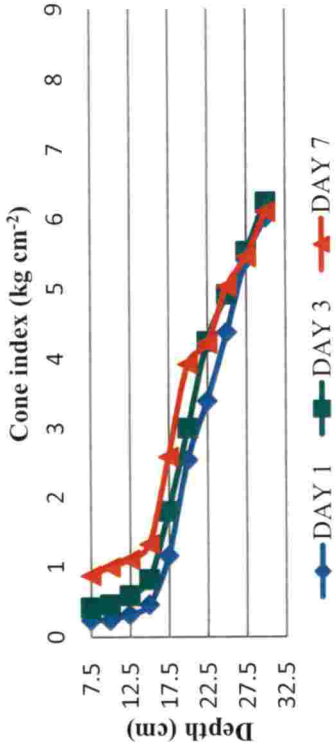

Change in cone index at different depths in bunds formed using BF2 - NH3230

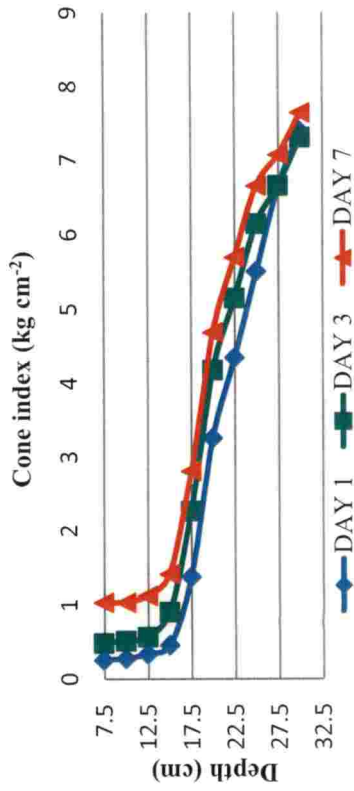
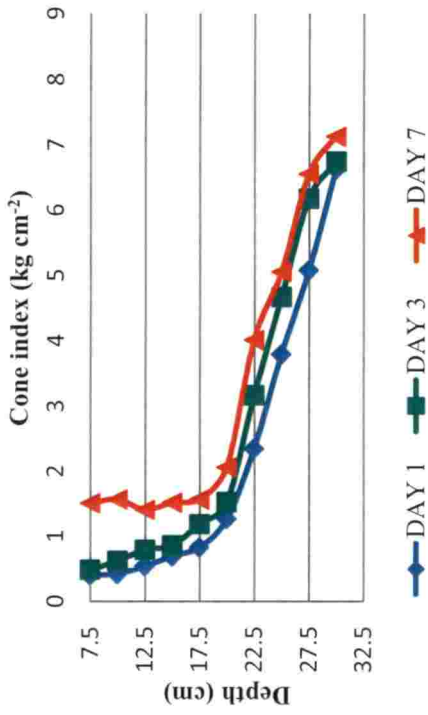

Fig. 4.21 (a) Changes in cone index (kg cm<sup>-2</sup>) at incremental depths over consecutive time intervals for manual bunds and bunds formed using BF1 and BF2 at Tavanur (Power source: NH 3230)

191

Change in cone index at different depths in bunds formed using BF3 - NH3230



Change in cone index at different depths in bunds formed by BF4 - NH3230

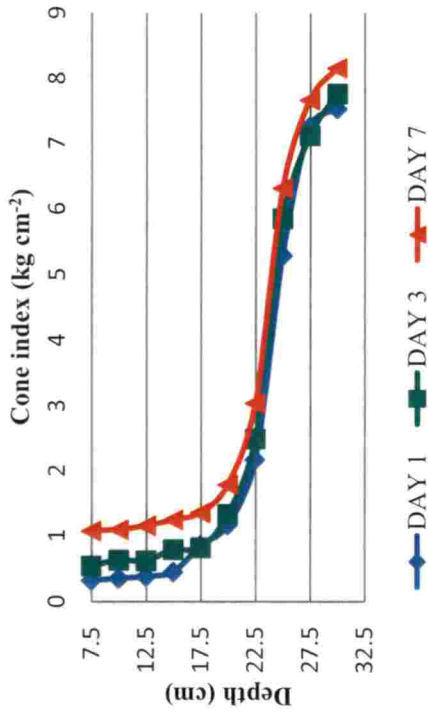
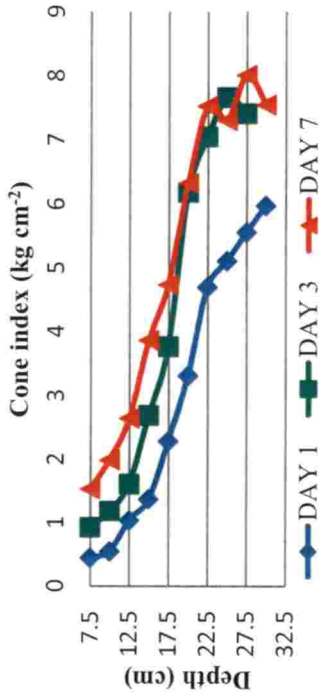

Fig. 4.21 (b) Changes in cone index (kg cm<sup>-2</sup>) at incremental depths over consecutive time intervals for bunds formed using BF3 and BF4 at Tavanur (Power source: NH 3230)

192



Change in cone index at different depths in manually formed bunds



Change in cone index at different depths in bunds formed using BF1-KTT

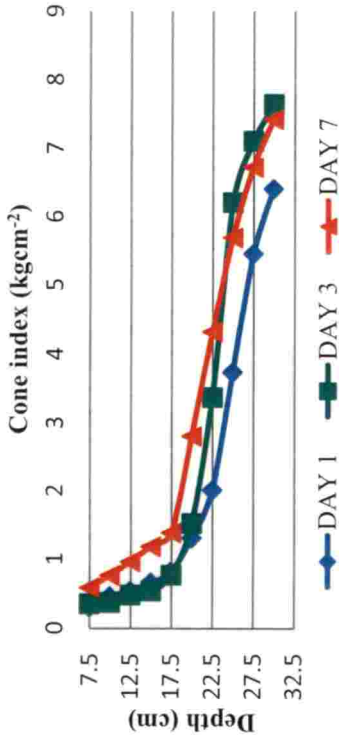

Change in cone index at different depths in bunds formed using BF2 - KTT

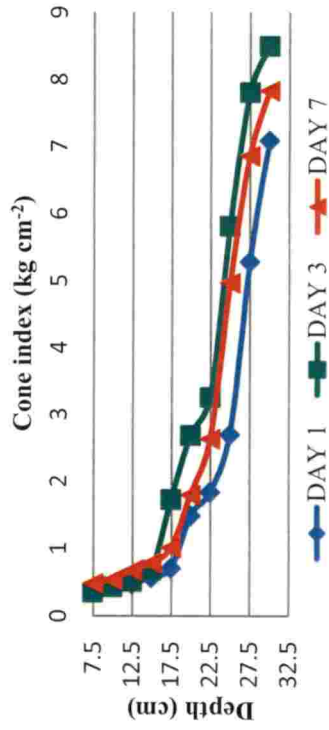

Fig. 4.22 Changes in cone index (kg cm<sup>-2</sup>) at incremental depths over consecutive time intervals for manual bunds and bunds formed using BF1 and BF2 at Tavanur (Power source: KTT)

The variation in the values of cone index at incremental depths for the various types of bunds formed using NH 3230 are shown in Fig. 4.23 to 4.25. The values are presented in Appendix V.

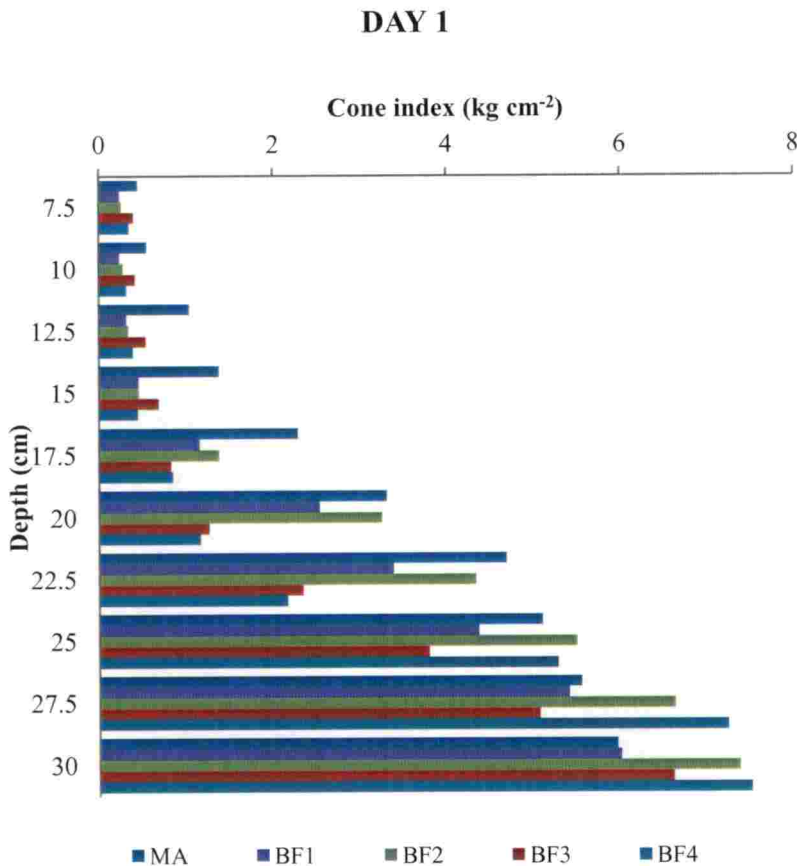

Fig. 4.23 Variation of cone index with depth in different bunds formed with NH 3230 on Day 1 at Tavanur

The progressive relative changes in the cone penetration resistance at different depths over the different types of bunds formed using the NH 3230 tractor were observed. The changes occurring due to loss of moisture / shrinkage in the bunds formed under the five different methods were measured based on values of cone index measured at the ten depths, as at other locations.

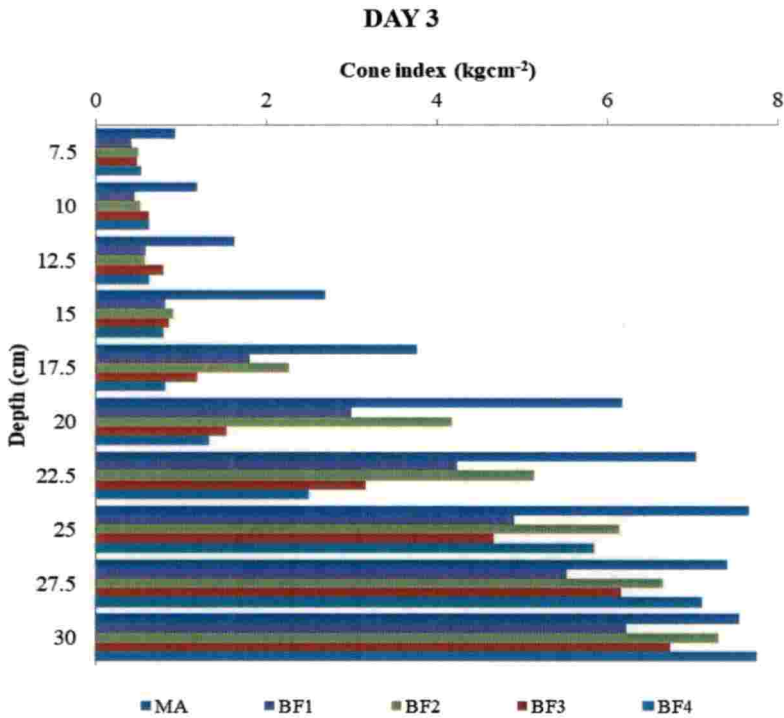

Fig. 4.24 Variation of cone index with depth in different bunds formed with NH 3230 on Day 3 at Tavanur

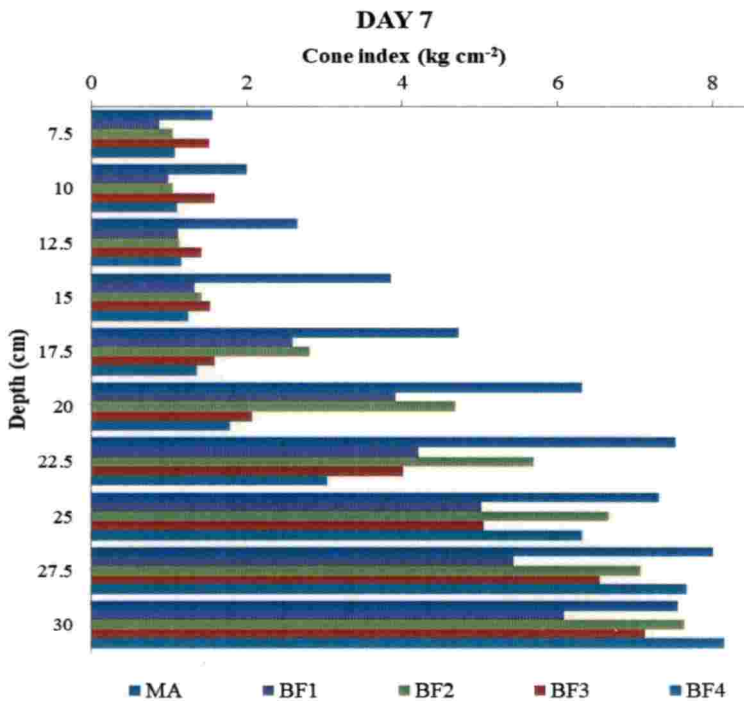

Fig. 4.25 Variation of cone index with depth in different bunds formed with NH 3230 on Day 7 at Tavanur

195

The consecutive relative changes up to seven days, measured as the relative change from first day to the third day and third day to seventh day are presented in Tables 4.50 to 4.59. As the relative changes varied widely, square root transformation was resorted to so as to conform to the basic assumption of ANOVA.

The consecutive relative changes in cone index at the depth of 7.5 cm are indicated in Table 4.50. In general, the maximum relative change occurred from the third day to the seventh day, when the changes happening in the soil were nearing stabilization.

Table 4.50 Consecutive relative changes in cone index ( $\text{kg cm}^{-2}$ ) of bunds formed at Tavanur by various methods, using NH 3230 tractor at 7.5 cm depth

Change in cone index	Type of bund formation					Mean across different bund types
	Manual	Mechanical – BF3	Mechanical – BF2	Mechanical – BF1	Mechanical – BF4	
Day 1 to Day 3	109.22 (10.23)	21.59 (4.70)	92.18 (9.77)	75.75 (8.47)	55.96 (7.39)	70.940 (8.11)
Day 3 to Day 7	101.58 (8.62)	221.57 (15.04)	111.87 (10.84)	123.49 (11.07)	105.19 (10.50)	132.74 (11.21)
<b>Mean change in cone index</b>	105.40 (9.43)	121.58 (9.87)	102.03 (10.30)	99.62 (9.77)	80.58 (8.94)	<b>CD1 – 1.81</b> <b>CD2 – NS</b> <b>CD3 – 4.04</b>

(figures in parentheses are square root transformed values)

NS= Not significant

CD1 = CD for comparison of change in cone indices from day 1 to day 3 with changes from day 3 to day 7

CD2 = CD for comparison of cone indices under the different types of bund formation

CD3 = CD for interaction

When viewed based on the type of bund formation, in general, no significant difference was noticed. However the differential response in values of cone index with respect to the different bund strengthening implements was

noticed, as evidenced from significance of the interaction effect. The interaction effect showed a zigzag variation and in certain special circumstances, the changes in cone index values were on par between BF3 and BF1, when the changes were measured from the third day to the seventh day. In contrast, the change in cone index was comparatively low under BF3. This peculiar observation is an endorsement of the general procedure of forming bunds in this area where very large bunds measuring 40 to 50 cm in width and 60 to 70 cm in height are noticeable and the ultimate purpose of this experimentation is only to test verify whether a subdivision of the existing big fields is feasible.

The relative changes in cone indices at subsequent depths of 10 cm, 12.5 cm, 15 cm, 17.5 cm, 20 cm, 22.5 cm, 25 cm, 27.5 cm and 30 cm are presented in Tables 4.51 to 4.59.

Table 4.51 Consecutive relative changes in cone index ( $\text{kg cm}^{-2}$ ) of bunds formed at Tavanur by various methods, using NH 3230 tractor, at 10.0 cm depth

Change in cone index	Type of bund formation					Mean across different bund types
	Manual	Mechanical – BF3	Mechanical – BF2	Mechanical – BF1	Mechanical – BF4	
Day 1 to Day 3	125.21 (11.04)	58.00 (7.19)	95.47 (9.53)	99.17 (9.54)	102.76 (9.81)	96.12 (9.42)
Day 3 to Day 7	86.85 (8.56)	158.73 (12.55)	98.55 (9.94)	116.23 (10.76)	75.96 (8.71)	107.26 (10.11)
<b>Mean change in cone index</b>	106.03 (9.80)	108.37 (9.87)	97.01 (9.74)	107.70 (10.15)	89.36 (9.26)	<b>CD1 – NS</b> <b>CD2 – NS</b> <b>CD3 –3.17</b>

(figures in parentheses are square root transformed values)

NS= Not significant

CD1 = CD for comparison of change in cone indices from day 1 to day 3 with changes from day 3 to day 7

CD2 = CD for comparison of cone indices under the different types of bund formation

CD3 = CD for interaction

Table 4.52 Consecutive relative changes in cone index ( $\text{kg cm}^{-2}$ ) of bunds formed at Tavanur by various methods, using NH 3230 tractor, at 12.5 cm depth

Change in cone index	Type of bund formation					Mean across different bund types
	Manual	Mechanical – BF3	Mechanical – BF2	Mechanical – BF1	Mechanical – BF4	
Day 1 to Day 3	59.95 (7.58)	50.76 (6.83)	85.09 (8.44)	96.89 (9.00)	65.74 (7.44)	71.68 (7.86)
Day 3 to Day 7	70.72 (7.78)	82.80 (9.03)	100.06 (9.99)	97.44 (9.66)	93.03 (9.62)	88.81 (9.22)
<b>Mean change in cone index</b>	65.34 (7.68)	66.78 (7.93)	92.57 (9.22)	97.16 (9.33)	79.38 (8.53)	<b>CD1 - NS</b> <b>CD2 - NS</b> <b>CD3 - NS</b>

Table 4.53 Consecutive relative changes in cone index ( $\text{kg cm}^{-2}$ ) of bunds formed at Tavanur by various methods, using NH 3230 tractor, at 15.0 cm depth

Change in cone index	Type of bund formation					Mean across different bund types
	Manual	Mechanical – BF3	Mechanical – BF2	Mechanical – BF1	Mechanical – BF4	
Day 1 to Day 3	104.67 (10.13)	26.92 (5.24)	108.13 (9.83)	83.89 (9.06)	84.17 (7.56)	81.56 (8.36)
Day 3 to Day 7	44.65 (5.87)	79.20 (9.03)	58.61 (7.87)	65.13 (8.19)	71.87 (8.57)	63.89 (7.91)
<b>Mean change in cone index</b>	74.66 (8.00)	53.06 (7.14)	83.37 (8.85)	74.51 (8.63)	78.02 (8.06)	<b>CD1 - NS</b> <b>CD2 - NS</b> <b>CD3 - NS</b>

(figures in parentheses are square root transformed values)

NS= Not significant

CD1 = CD for comparison of change in cone indices from day 1 to day 3 with changes from day 3 to day 7

CD2 = CD for comparison of cone indices under the different types of bund formation

CD3 = CD for interaction

Table 4.54 Consecutive relative changes in cone index ( $\text{kg cm}^{-2}$ ) of bunds formed at Tavanur by various methods, using NH 3230 tractor, at 17.5 cm depth

Change in cone index	Type of bund formation					Mean across different bund types
	Manual	Mechanical – BF3	Mechanical – BF2	Mechanical – BF1	Mechanical – BF4	
Day 1 to Day 3	88.65 (11.73)	47.48 (10.15)	99.06 (11.86)	71.87 (11.23)	23.02 (7.77)	66.02 (10.55)
Day 3 to Day 7	33.96 (9.05)	34.71 (9.72)	24.59 (9.20)	45.45 (10.22)	72.51 (11.48)	42.24 (9.93)
<b>Mean change in cone index</b>	61.30 (10.39)	41.10 (9.94)	61.82 (10.53)	58.66 (10.72)	47.77 (9.62)	<b>CD1 - NS</b> <b>CD2 - NS</b> <b>CD3 - NS</b>

Table 4.55 Consecutive relative changes in cone index ( $\text{kg cm}^{-2}$ ) of bunds formed at Tavanur by various methods, using NH 3230 tractor, at 20.0 cm depth

Change in cone index	Type of bund formation					Mean across different bund types
	Manual	Mechanical – BF3	Mechanical – BF2	Mechanical – BF1	Mechanical – BF4	
Day 1 to Day 3	89.93 (11.47)	20.68 (7.95)	33.96 (8.63)	24.91 (8.09)	30.80 (7.96)	40.06 (8.82)
Day 3 to Day 7	3.35 (6.22)	38.05 (9.04)	12.43 (7.51)	31.56 (8.64)	36.13 (8.94)	24.30 (8.07)
<b>Mean change in cone index</b>	46.64 (8.84)	29.36 (8.50)	23.20 (8.07)	28.23 (8.36)	33.47 (8.45)	<b>CD1 - NS</b> <b>CD2 - NS</b> <b>CD3 - 2.58</b>

(figures in parentheses are square root transformed values)

NS= Not significant

CD1 = CD for comparison of change in cone indices from day 1 to day 3 with changes from day 3 to day 7

CD2 = CD for comparison of cone indices under the different types of bund formation

CD3 = CD for interaction

Table 4.56 Consecutive relative changes in cone index ( $\text{kg cm}^{-2}$ ) of bunds formed at Tavanur by various methods, using NH 3230 tractor, at 22.5 cm depth

Change in cone index	Type of bund formation					Mean across different bund types
	Manual	Mechanical – BF3	Mechanical – BF2	Mechanical – BF1	Mechanical – BF4	
Day 1 to Day 3	88.65 (9.21)	47.48 (7.53)	99.06 (7.33)	71.87 (7.75)	23.02 (7.65)	66.02 (7.89)
Day 3 to Day 7	33.96 (6.30)	34.71 (8.11)	24.59 (6.75)	45.45 (5.84)	72.51 (7.58)	42.24 (6.92)
Mean change in cone index	61.30 (7.75)	41.10 (7.82)	61.82 (7.04)	58.66 (6.80)	47.77 (7.61)	CD1 - NS CD2 - NS CD3 - NS

Table 4.57 Consecutive relative changes in cone index ( $\text{kg cm}^{-2}$ ) of bunds formed at Tavanur by various methods, using NH 3230 tractor, at 25.0 cm depth

Change in cone index	Type of bund formation					Mean across different bund types
	Manual	Mechanical – BF3	Mechanical – BF2	Mechanical – BF1	Mechanical – BF4	
Day 1 to Day 3	50.65 (8.85)	24.03 (7.23)	11.73 (6.35)	12.58 (6.44)	10.88 (6.20)	21.97 (7.01)
Day 3 to Day 7	-3.49 (4.57)	8.33 (6.11)	8.39 (6.11)	2.34 (5.58)	8.44 (6.12)	4.80 (5.70)
Mean change in cone index	23.58 (6.71)	16.18 (6.67)	10.06 (6.23)	7.46 (6.01)	9.67 (6.16)	CD1 – 0.61 CD2 – NS CD3 – 1.36

(figures in parentheses are square root transformed values)

NS= Not significant

CD1 = CD for comparison of change in cone indices from day 1 to day 3 with changes from day 3 to day 7

CD2 = CD for comparison of cone indices under the different types of bund formation

CD3 = CD for interaction



Table 4.58 Consecutive relative changes in cone index ( $\text{kg cm}^{-2}$ ) of bunds formed at Tavanur by various methods, using NH 3230 tractor, at 27.5 cm depth

Change in cone index	Type of bund formation					Mean across different bund types
	Manual	Mechanical – BF3	Mechanical – BF2	Mechanical – BF1	Mechanical – BF4	
Day 1 to Day 3	33.54 (6.98)	23.51 (6.39)	1.69 (4.24)	2.36 (4.53)	-1.26 (3.83)	11.97 (5.20)
Day 3 to Day 7	13.24 (4.86)	6.30 (5.03)	6.25 (5.01)	-1.10 (4.14)	7.71 (5.17)	6.48 (4.84)
<b>Mean change in cone index</b>	23.39 (5.92)	14.91 (5.71)	3.97 (4.63)	0.63 (4.33)	3.23 (4.50)	<b>CD1 – NS</b> <b>CD2 – NS</b> <b>CD3 – NS</b>

Table 4.59 Consecutive relative changes in cone index ( $\text{kg cm}^{-2}$ ) of bunds formed at Tavanur by various methods, using NH 3230 tractor, at 30.0 cm depth

Change in cone index	Type of bund formation					Mean across different bund types
	Manual	Mechanical – BF3	Mechanical – BF2	Mechanical – BF1	Mechanical – BF4	
Day 1 to Day 3	26.50 (6.93)	2.08 (5.26)	-0.55 (4.97)	3.79 (5.45)	3.42 (5.37)	7.05 (5.60)
Day 3 to Day 7	6.35 (4.80)	5.79 (5.64)	4.69 (5.52)	-2.09 (4.86)	5.39 (5.60)	4.03 (5.28)
<b>Mean change in cone index</b>	16.43 (5.86)	3.93 (5.45)	2.07 (5.25)	0.85 (5.16)	4.41 (5.48)	<b>CD1 – NS</b> <b>CD2 – NS</b> <b>CD3 – NS</b>

(figures in parentheses are square root transformed values)

NS= Not significant

CD1 = CD for comparison of change in cone indices from day 1 to day 3 with changes from day 3 to day 7

CD2 = CD for comparison of cone indices under the different types of bund formation

CD3 = CD for interaction

The slow drying effect will be evidenced as these tables are perused, with rarely a significant difference / differential response in the cone index noticed. Whenever a significant difference is noticed, the said reading may be attributed to

the basal soil conditions including presence of hard soil pan, voids or less compacted areas, vegetative residues etc. Generally, the relative changes in the values of the cone index were uniform.

The relative changes in cone index from first day to the third day as also from third day to the seventh day were found to be statistically non-significant with respect to the manually formed bunds, bunds formed using BF2, BF1 and BF4, as regards the penetration resistance offered, and thus the strength of the bund. Thus the general conclusion that may be drawn at this juncture is that BF2 or BF4 is suitable to the area, in terms of strength of bund.

Figures 4.26 to 4.28 show the variation in cone index in the bunds formed by the different bund strengthening implements and KTT as the power source, along the depth, on the day of bund formation and on the third and seventh day after formation.

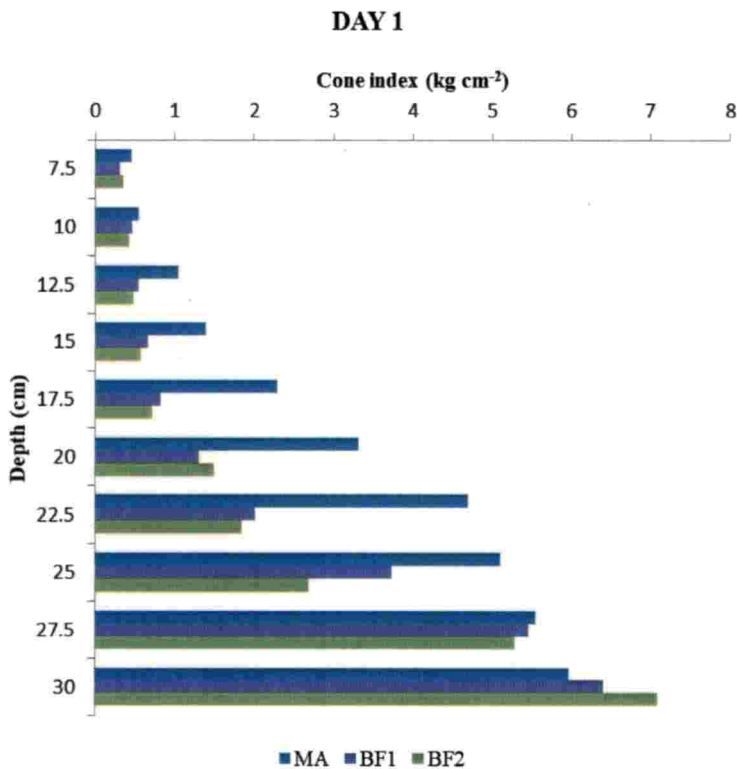

Fig. 4.26 Variation of cone index with depth in different bunds formed with KTT on Day 1 at Tavanur

202

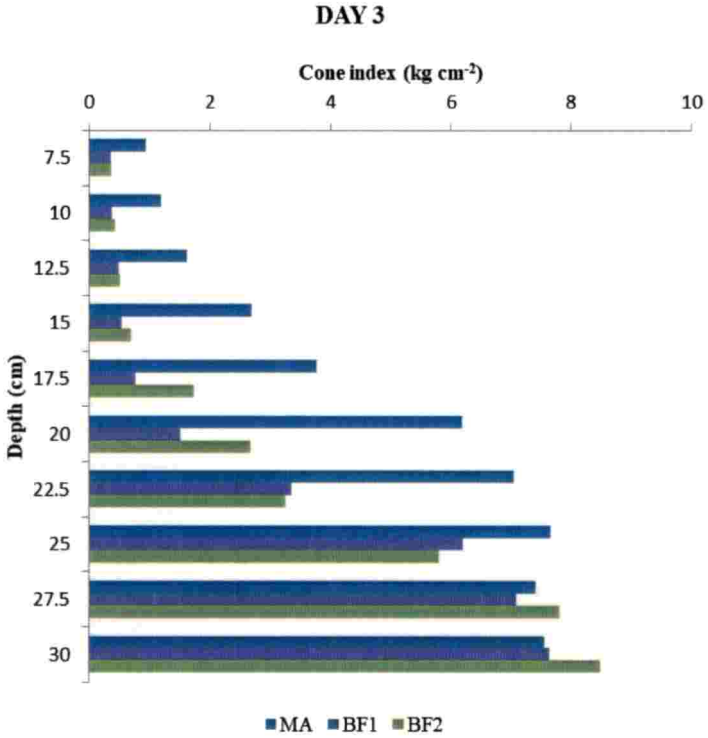

Fig. 4.27 Variation of cone index with depth in different bunds formed with KTT on Day 3 at Tavanur

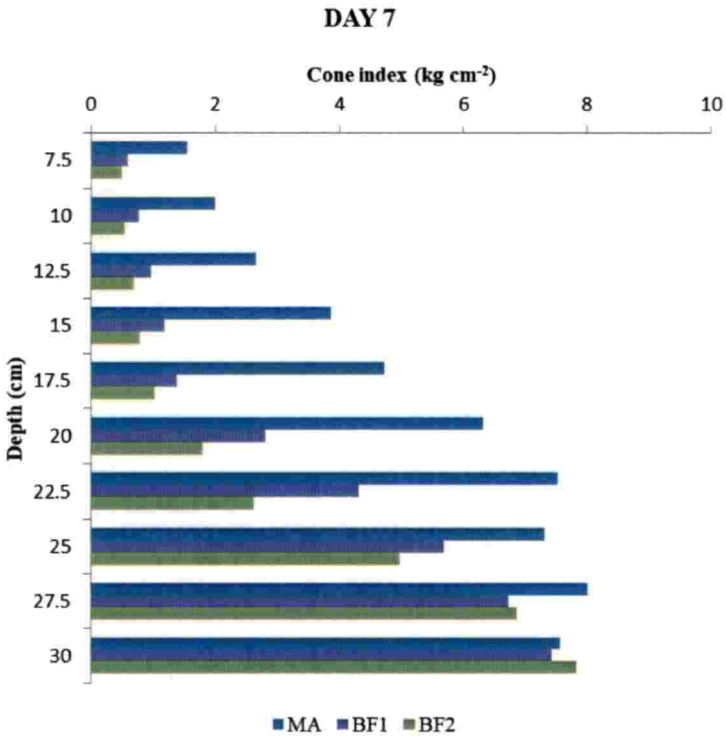

Fig. 4.28 Variation of cone index with depth in different bunds formed with KTT on Day 7 at Tavanur

203

It is observed that the values of cone index tend to increase along depth in all cases, as observed in other tests. The values of cone index of the manually formed bunds are higher at almost all depths.

The bunds formed mechanically show an increase in values at the lower depths of 27.5 and 30.0 cm. But the difference in comparison with the values observed on the manual bunds decrease with time. The initial increase may be due to the movement of the implement in the soil. As the implement penetrates the soil to some depth during bund formation, the volume of soil may experience compaction which may contribute to its increased resistance. But as the bigger manual bund firms up by losing moisture, its resistance values also increase.

#### **4.5.5 Shear Strength of Formed Bunds**

Shear strength of the different types of bunds formed were measured as explained in Section 3.4.5.

##### ***4.5.5.1 Changes in Shear Strength Observed in the Different Bunds Formed at Pullazhi Kole***

The observations of shear strength, measured in situ using the vane shear test, at the three depths *viz.*, 0.20 m, 0.40 m and 0.60 m, are presented in Tables 4.60 to 4.62. The observations of shear strength on the day of bund formation at 0.20 m depth showed that the manually formed bunds had the lowest values of strength. The mechanically formed bunds showed an increasing trend in shear strength values. The bunds formed by BF2 exhibits higher values of shear strength throughout the observation period. By the third day, all the mechanically formed bunds showed values on par and more than those of manually formed bunds; a similar observation being obtained on the seventh day also.

When the depth of measurement went down to 0.40 m also, the bunds formed by BF2 exhibited the highest values. The strengths exhibited were of the same order and similar for the time of observation, as at the earlier depth of 0.20 m. Strength of the manually formed bund was seen to be on par with the

mechanically formed bunds using BF3 on the first day. By the seventh day the mechanically formed bunds were seen to have higher shear strength as compared to the bunds formed manually, except for the bunds formed by BF1.

Table 4.60 Summary of changes in shear strength at a depth of 0.20 m at consecutive time intervals at Pullazhi kole

Sl. No.	Method of bund formation	Shear strength (kPa)		
		Day 1	Day 3	Day 7
1	Manually formed	4.34 <sup>d</sup>	7.81 <sup>b</sup>	24.31 <sup>c</sup>
2	Mechanically formed –BF1	34.73 <sup>b</sup>	33.00 <sup>a</sup>	46.02 <sup>a</sup>
3	Mechanically formed –BF2	46.02 <sup>a</sup>	36.47 <sup>a</sup>	40.81 <sup>ab</sup>
4	Mechanically formed –BF3	25.18 <sup>c</sup>	32.99 <sup>a</sup>	37.34 <sup>b</sup>

Table 4.61 Summary of changes in shear strength at a depth of 0.40 m at consecutive time intervals at Pullazhi kole

Sl. No.	Method of bund formation	Shear strength (kPa)		
		Day 1	Day 3	Day 7
1	Manually formed	31.26 <sup>c</sup>	33.86 <sup>b</sup>	48.62 <sup>b</sup>
2	Mechanically formed –BF1	49.49 <sup>b</sup>	58.18 <sup>a</sup>	33.86 <sup>c</sup>
3	Mechanically formed –BF2	75.54 <sup>a</sup>	70.33 <sup>a</sup>	76.41 <sup>a</sup>
4	Mechanically formed –BF3	33.86 <sup>c</sup>	62.52 <sup>a</sup>	69.47 <sup>a</sup>

Table 4.62 Summary of changes in shear strength at a depth of 0.60 m at consecutive time intervals at Pullazhi kole

Sl. No.	Method of bund formation	Shear strength (kPa)		
		Day 1	Day 3	Day 7
1	Manually formed	14.76 <sup>b</sup>	17.36 <sup>b</sup>	20.84 <sup>ab</sup>
2	Mechanically formed –BF1	13.02 <sup>b</sup>	17.36 <sup>b</sup>	17.36 <sup>b</sup>
3	Mechanically formed –BF2	47.76 <sup>a</sup>	42.55 <sup>a</sup>	23.44 <sup>a</sup>
4	Mechanically formed –BF3	16.50 <sup>b</sup>	19.10 <sup>b</sup>	19.97 <sup>ab</sup>

205

When shear strength was measured at the depth of 0.60 m, observations on the first day and third day showed on par readings among all the types of bunds formed, except the bunds formed by BF2, which had the highest value. The strength of these bunds remained highest throughout the observation period. By the seventh day, the bunds formed using BF3, and the manually formed bunds had strengthened more than the bunds made by BF1.

Figure 4.29 depicts how shear strength, measured *in situ* using the vane shear apparatus, varied in the different types of bunds formed at Pullazhi kole fields, at consecutive time intervals.

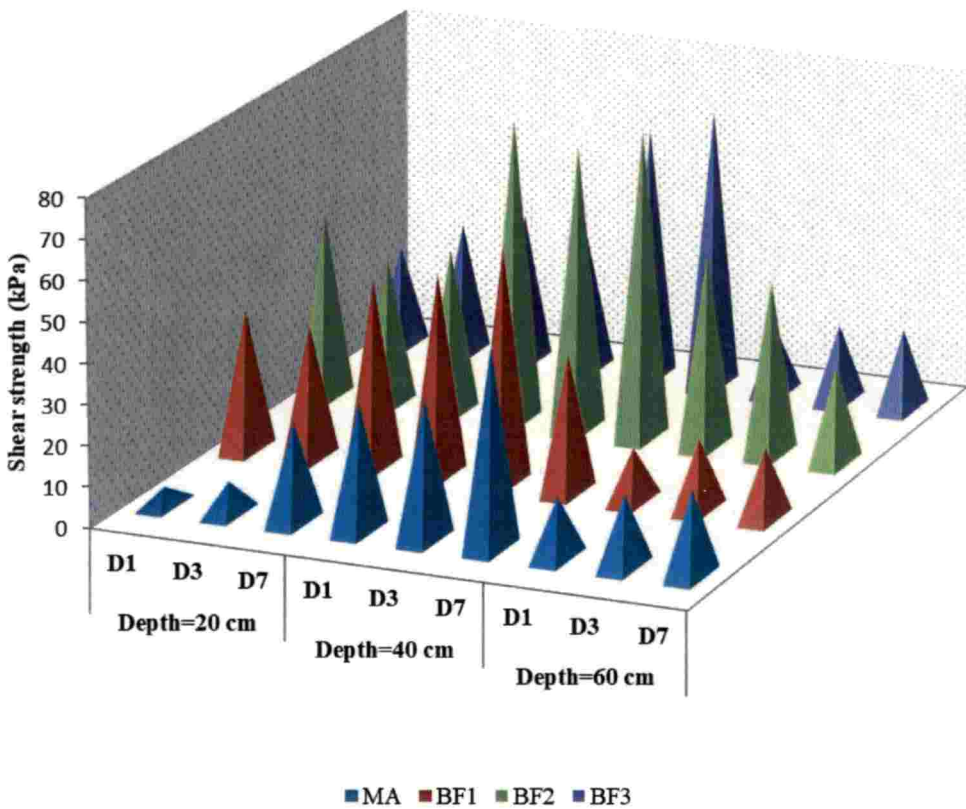

Fig. 4.29 Changes in *in situ* shear strength of different bunds formed at Pullazhi kole fields at consecutive time intervals and depths

**4.5.5.2 Changes in Shear Strength Observed in the Different Bunds Formed at Ponnani Kole**

Tables 4.63 to 4.65 summarise the changes in the values of shear strengths measured at different depths at the Kolothumpadam kolepadavu, Ponnani kole.

Table 4.63 Summary of changes in shear strength at a depth of 0.20 m at consecutive intervals at Ponnani kole

Sl. No.	Method of bund formation	Shear strength (kPa)		
		Day 1	Day 3	Day 7
1	Manually formed	6.94 <sup>c</sup>	13.02 <sup>c</sup>	22.57 <sup>c</sup>
2	Mechanically formed –BF2	22.57 <sup>b</sup>	27.78 <sup>b</sup>	39.94 <sup>b</sup>
3	Mechanically formed –BF3	28.65 <sup>a</sup>	37.34 <sup>a</sup>	55.57 <sup>a</sup>
4	Mechanically formed –BF4	27.78 <sup>a</sup>	35.60 <sup>a</sup>	59.05 <sup>a</sup>

Table 4.64 Summary of changes in shear strength at a depth of 0.40 cm at consecutive intervals at Ponnani kole

Sl. No.	Method of bund formation	Shear strength (kPa)		
		Day 1	Day 3	Day 7
1	Manually formed	42.55 <sup>b</sup>	47.76 <sup>c</sup>	74.67 <sup>b</sup>
2	Mechanically formed –BF2	49.49 <sup>b</sup>	56.44 <sup>b</sup>	79.88 <sup>ab</sup>
3	Mechanically formed –BF3	65.99 <sup>a</sup>	77.28 <sup>a</sup>	85.09 <sup>ab</sup>
4	Mechanically formed –BF4	70.33 <sup>a</sup>	81.62 <sup>a</sup>	86.83 <sup>a</sup>

At the depth of 0.20 m, the bunds formed mechanically using BF3 and BF4 showed the highest and on par values for shear strength, followed by the bunds formed by BF2. The values of shear strength for the manually formed

207

bunds were the lowest. The same trend was observed throughout the period of observation, with the values being considerably less throughout. The soil here had a higher percentage of clay compared to the earlier soil type; and the force applied by the labour during manual formation of bunds being less; lesser strength is imparted to the upper layers of the bund.

The same pattern of readings was seen for values of shear strength at the depth of 0.40 m, and the bunds became stronger by the seventh day. The mechanically formed bunds were all on par in terms of strength.

Table 4.65 Summary of changes in shear strength at a depth of 0.60 m at consecutive intervals at Ponnani *kole*

Sl. No.	Method of bund formation	Shear strength (kPa)		
		Day 1	Day 3	Day 7
1	Manually formed	72.07 <sup>b</sup>	77.28 <sup>b</sup>	108.54 <sup>a</sup>
2	Mechanically formed –BF2	70.33 <sup>b</sup>	88.57 <sup>ab</sup>	100.72 <sup>a</sup>
3	Mechanically formed –BF3	82.49 <sup>a</sup>	98.12 <sup>a</sup>	108.54 <sup>a</sup>
4	Mechanically formed –BF4	80.75 <sup>a</sup>	100.72 <sup>a</sup>	102.46 <sup>a</sup>

At the depth of 0.60 m, the shear strength of the bunds formed mechanically with BF3 and BF4 showed the highest values; and the manually formed bunds were on par with the bunds formed by BF2. Shear strength increased considerably in all cases and as time progresses, almost all the bunds were seen to have comparable strength values.

The distribution of the shear strength over depth and time is shown in Fig. 4.30.



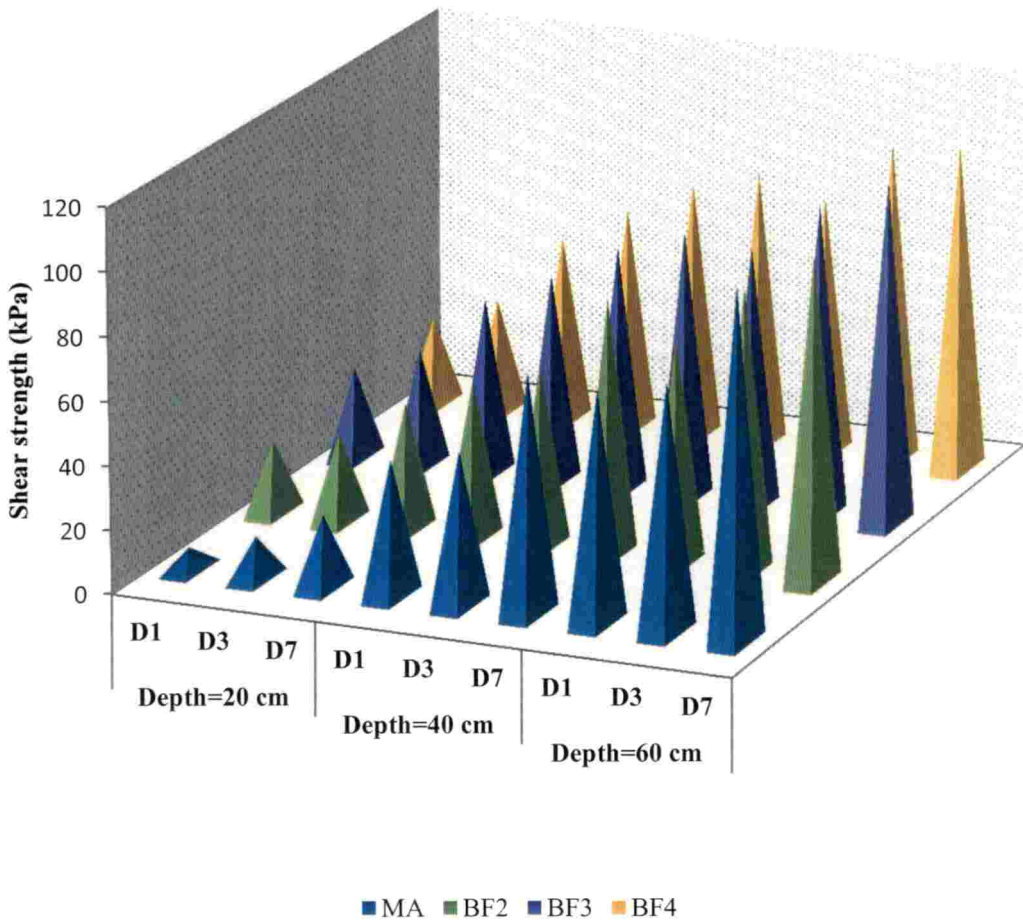

Fig. 4.30 Changes in *in situ* shear strength of different bunds formed at Ponnani kole fields at consecutive time intervals and depths

#### 4.5.5.3 Changes in Shear Strength Observed in the Different Bunds Formed at Tavanur

The variations in shear strength of the bunds formed by NH 3230 and KTT, measured as explained in Section 3.5.5, are shown in Figures 4.31 and 4.32.

209

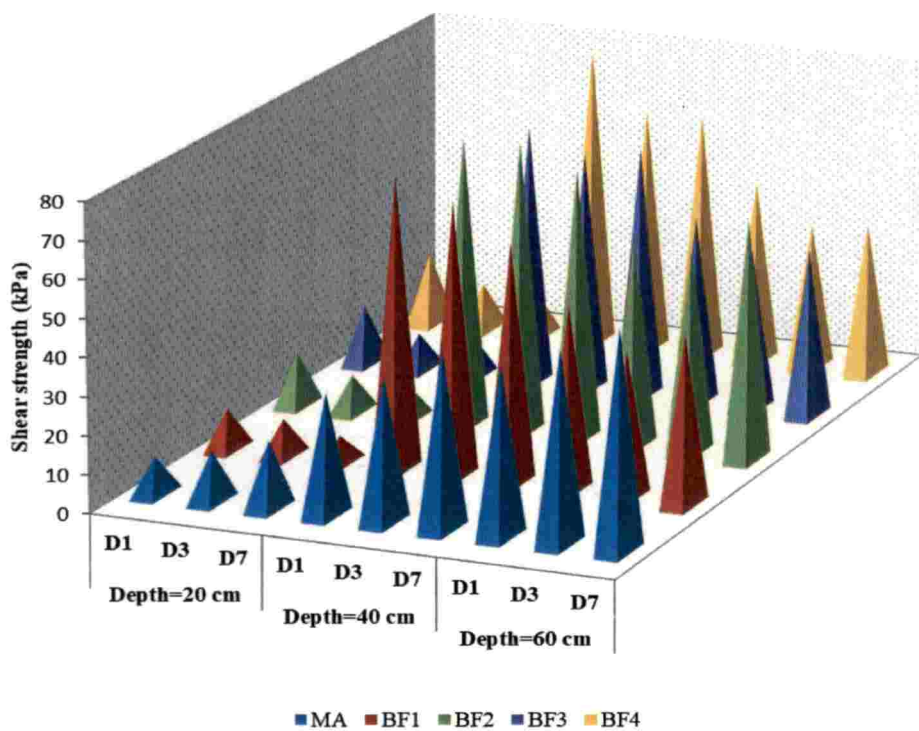

Fig. 4.31 Changes in *in situ* shear strength of different bunds formed at Tavanur fields using NH 3230

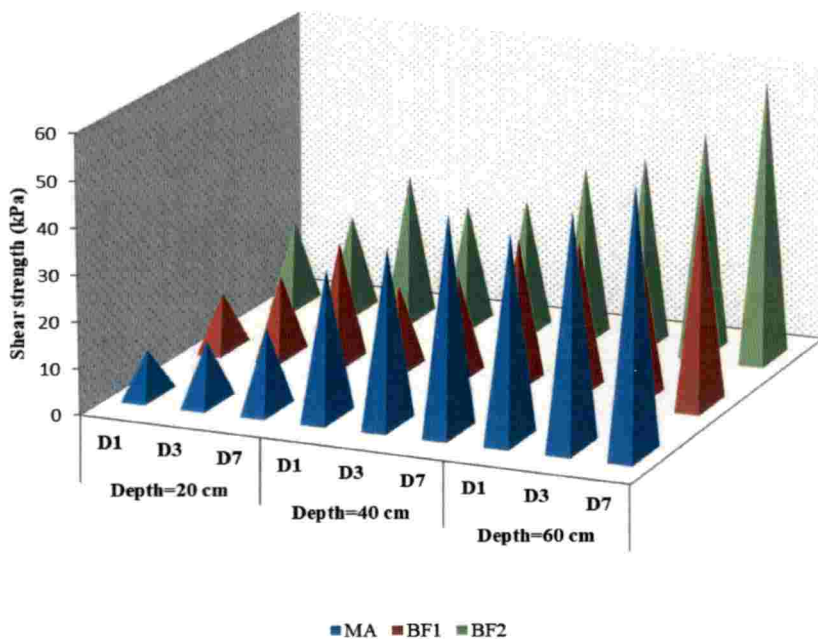

Fig. 4.32 Changes in *in situ* shear strength of different bunds formed at Tavanur fields using KTT

During measurement of the shear strength at the depth of 0.20 m on the day of bund formation, using the NH 3230 tractor, it was observed that shear strength was highest for the bunds formed by BF4, which was comparable with the bunds formed using BF3. Strengths of the mechanically formed bunds using BF2 lay between the bunds formed by BF3 and BF1. The strengths of the bunds formed manually and using BF1 were on par and had the lowest values of shear strength, which could be indicative of lesser compaction.

By the third day all bunds exhibited similarity in terms of shear strength, but when observed on the seventh day, the manually formed bunds had a higher value of shear strength when compared to the mechanically formed ones. The observations are summarised in Table 4.66.

Table 4.66 Summary of changes in shear strength at a depth of 0.20 m at consecutive intervals at Tavanur using NH 3230 tractor

Sl. No.	Method of bund formation	Shear Strength (kPa)		
		Day 1	Day 3	Day 7
1	Manually formed	9.55 <sup>c</sup>	13.02 <sup>a</sup>	17.36 <sup>a</sup>
2	Mechanically formed –BF1	10.42 <sup>c</sup>	9.55 <sup>a</sup>	6.94 <sup>b</sup>
3	Mechanically formed –BF2	13.89 <sup>bc</sup>	9.55 <sup>a</sup>	8.68 <sup>b</sup>
4	Mechanically formed –BF3	15.63 <sup>ab</sup>	9.55 <sup>a</sup>	10.42 <sup>b</sup>
5	Mechanically formed –BF4	19.10 <sup>a</sup>	12.16 <sup>a</sup>	11.29 <sup>b</sup>

At the depth of 0.40 m, the order of the bunds, in terms of decreasing strengths on the first day were bunds formed mechanically using BF4, (BF1, BF2), followed by BF3 and then the manually formed bunds. By the third day, a pairing of the bunds formed by BF3 and BF4, and BF1 and BF2 was observed. By the seventh day of observation, all the mechanically formed bunds were on par (Table 4.67).

Table 4.67 Summary of changes in shear strength at a depth of 0.40 m at consecutive intervals at Tavanur using NH 3230 tractor

Sl. No.	Method of bund formation	Shear Strength (kPa)		
		Day 1	Day 3	Day 7
1	Manually formed	31.26 <sup>c</sup>	37.34 <sup>c</sup>	46.02 <sup>b</sup>
2	Mechanically formed –BF1	77.28 <sup>ab</sup>	71.20 <sup>b</sup>	62.52 <sup>a</sup>
3	Mechanically formed –BF2	75.54 <sup>ab</sup>	76.41 <sup>a</sup>	70.33 <sup>a</sup>
4	Mechanically formed –BF3	68.60 <sup>b</sup>	63.39 <sup>b</sup>	65.99 <sup>a</sup>
5	Mechanically formed –BF4	79.01 <sup>a</sup>	64.26 <sup>b</sup>	64.25 <sup>a</sup>

For the measurements taken at 0.60 m depth, as seen from Table 4.68, the first day's observations showed that the bunds formed by BF3, BF1 and BF4 had similar distribution of the shear strength, These values were not very different from the strength of the manually formed bunds also. However the bunds formed by BF2 had higher values. The ordering of the strength of bunds changed to bunds formed by (manual, BF2) and (BF3, BF1, BF4) on the third and seventh day.

Table 4.68 Summary of changes in shear strength at a depth of 0.60 m at consecutive intervals at Tavanur using NH 3230 tractor

Sl. No.	Method of bund formation	Shear Strength (kPa)		
		Day 1	Day 3	Day 7
1	Manually formed	43.42 <sup>b</sup>	49.49 <sup>a</sup>	56.44 <sup>a</sup>
2	Mechanically formed –BF1	48.62 <sup>ab</sup>	38.21 <sup>b</sup>	44.28 <sup>b</sup>
3	Mechanically formed –BF2	53.83 <sup>a</sup>	52.97 <sup>a</sup>	62.52 <sup>a</sup>
4	Mechanically formed –BF3	49.49 <sup>ab</sup>	42.55 <sup>b</sup>	44.28 <sup>b</sup>
5	Mechanically formed –BF4	47.76 <sup>ab</sup>	38.21 <sup>b</sup>	39.94 <sup>b</sup>

212

When the bunds were formed using KTT as the power source, the strength of the mechanically formed bund using BF2 was found to be the highest throughout the period of observation, at depth of 0.20 m. Though, on the first day, the manually formed bund and the bund formed using BF1 showed similarity in shear strength values, these values increased for the bund formed by BF1 as time progressed and on the seventh day there was a clear ordering of the strength as bund formed by BF2, BF1 and manually formed bund.

When the depth of measurement was increased to 0.40 m, the strength noted under the manually formed bunds was the highest throughout the period of observation, followed by the bunds formed mechanically using BF2 and BF1 respectively. By the seventh day, it was seen that the mechanically formed bunds using BF2 had an on par shear strength value with the manually formed bunds.

For the measurements taken at the depth of 0.60 m, the trend observed throughout the observation period was similar and in the decreasing order of strength as manually formed bunds, bund formed mechanically using BF2 and BF1. The observations are illustrated in Tables 4.69 to 4.71.

Table 4.69 Summary of changes in shear strength at a depth of 0.20 m at consecutive intervals at Tavanur using KTT

Sl. No.	Method of bund formation	Shear Strength (kPa)		
		Day 1	Day 3	Day 7
1	Manually formed	9.55 <sup>b</sup>	13.02 <sup>b</sup>	17.36 <sup>c</sup>
2	Mechanically formed –BF1	12.15 <sup>b</sup>	17.36 <sup>ab</sup>	26.05 <sup>b</sup>
3	Mechanically formed –BF2	18.23 <sup>a</sup>	20.84 <sup>a</sup>	31.26 <sup>a</sup>

Table 4.70 Summary of changes in shear strength at a depth of 0.40 m at consecutive intervals at Tavanur using KTT

Sl. No.	Method of bund formation	Shear Strength (kPa)		
		Day 1	Day 3	Day 7
1	Manually formed	31.26 <sup>a</sup>	37.34 <sup>a</sup>	46.02 <sup>a</sup>
2	Mechanically formed –BF1	18.23 <sup>c</sup>	21.71 <sup>c</sup>	31.26 <sup>c</sup>
3	Mechanically formed –BF2	26.05 <sup>b</sup>	28.65 <sup>b</sup>	37.34 <sup>b</sup>

Table 4.71 Summary of changes in shear strength at a depth of 0.60 m at consecutive intervals at Tavanur using KTT

Sl. No.	Method of bund formation	Shear Strength (kPa)		
		Day 1	Day 3	Day 7
1	Manually formed	43.41 <sup>a</sup>	49.49 <sup>a</sup>	56.44 <sup>a</sup>
2	Mechanically formed –BF1	32.13 <sup>b</sup>	33.86 <sup>b</sup>	46.02 <sup>b</sup>
3	Mechanically formed –BF2	40.81 <sup>a</sup>	47.76 <sup>a</sup>	59.91 <sup>a</sup>

#### 4.5.6 Moisture Content of Formed Bunds

Observations of moisture content of the soil samples taken from the bunds formed by the different methods were analysed as detailed in Section 3.5.6. The results obtained are presented in Table 4.72 to 4.74.

The moisture content of the bunds formed at the Pullazhi *kole* by the different methods was almost on par on the day of formation; the bunds formed by BF2 having the least moisture content. By the third day, the bunds formed by BF1 also dried out and was on par with those formed by BF2. On the seventh day of observation, it had the least moisture content. The manually formed bunds and those formed by BF3 were on par throughout the observation period and had the highest moisture content. The bunds formed by BF1 showed the largest

percentage reduction in moisture from the first day to the third day and from the third to the seventh day.

Table 4.72 Summary of changes in moisture content of the bunds at consecutive intervals at Pullazhi *kole*

Sl. No.	Method of bund formation	Moisture content (%)				
		Day 1	Day 3	Day 7	% change	
					D1 to D3	D3 to D7
1	Manual	55.83 <sup>a</sup>	54.45 <sup>a</sup>	52.68 <sup>a</sup>	-2.47	-3.25
2	Mechanically formed – BF1	54.29 <sup>ab</sup>	50.77 <sup>b</sup>	45.97 <sup>c</sup>	-6.48	-9.45
3	Mechanically formed – BF2	53.70 <sup>b</sup>	51.52 <sup>b</sup>	49.62 <sup>b</sup>	-4.06	-3.69
4	Mechanically formed – BF3	55.29 <sup>ab</sup>	54.89 <sup>a</sup>	51.96 <sup>a</sup>	-0.72	-5.34

Table 4.73 Summary of changes in moisture content of the bunds at consecutive intervals at Ponnani *kole*

Sl. No.	Method of bund formation	Moisture content (%)				
		Day 1	Day 3	Day 7	% change	
					D1 to D3	D3 to D7
1	Manual	65.02 <sup>a</sup>	57.33 <sup>a</sup>	56.78 <sup>a</sup>	-11.83	-0.96
2	Mechanically formed – BF2	61.07 <sup>b</sup>	58.24 <sup>a</sup>	57.47 <sup>a</sup>	-4.63	-1.32
3	Mechanically formed – BF3	60.68 <sup>b</sup>	58.53 <sup>a</sup>	57.81 <sup>a</sup>	-3.54	-1.23
4	Mechanically formed – BF4	57.44 <sup>c</sup>	56.45 <sup>a</sup>	54.69 <sup>b</sup>	-1.72	-3.12

Table 4.74 Summary of changes in moisture content of the bunds at consecutive intervals at Tavanur

Sl. No.	Method of bund formation	Moisture content (%)				
		Day 1	Day 3	Day 7	% change	
					D1 to D3	D3 to D7
1	Manual	47.11 <sup>a</sup>	44.38 <sup>a</sup>	40.94 <sup>a</sup>	-5.79	-7.75
2	Mechanically formed – BF1+NH 3230	47.44 <sup>a</sup>	45.36 <sup>a</sup>	39.66 <sup>abc</sup>	-4.38	-12.57
3	Mechanically formed – BF2+NH 3230	45.70 <sup>a</sup>	42.36 <sup>ab</sup>	41.08 <sup>a</sup>	-7.31	-3.02
4	Mechanically formed – BF3+NH 3230	45.94 <sup>a</sup>	42.45 <sup>ab</sup>	40.25 <sup>ab</sup>	-7.60	-5.18
5	Mechanically formed – BF4+NH 3230	42.79 <sup>a</sup>	38.59 <sup>b</sup>	36.26 <sup>bcd</sup>	-9.82	-6.04
6	Mechanically formed – BF1+KTT	42.95 <sup>a</sup>	37.34 <sup>b</sup>	35.86 <sup>cd</sup>	-13.06	-3.96
7	Mechanically formed – BF2+KTT	45.65 <sup>a</sup>	38.75 <sup>b</sup>	33.25 <sup>d</sup>	-15.12	-14.19

215

The variation in moisture content, over the observation period, in the different types of bunds formed at Pullazhi is shown in Fig. 4.33.

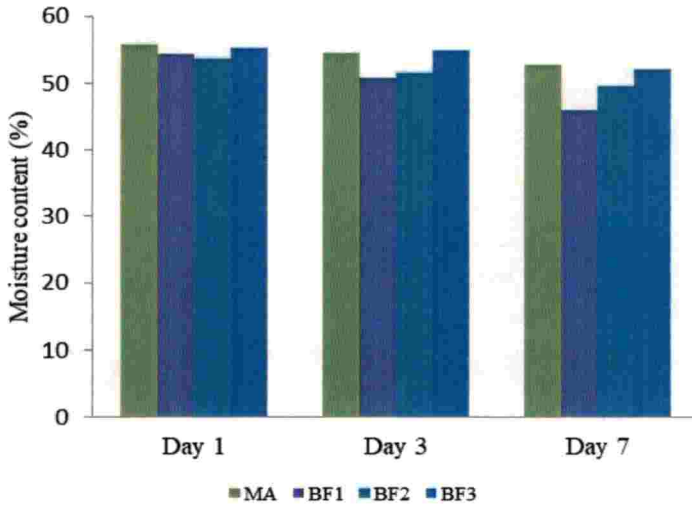

Fig. 4.33 Changes in moisture content of the different bunds at Pullazhi *kole*

Figure 4.34 shows such changes occurring in bunds formed at Ponnani *kole*.

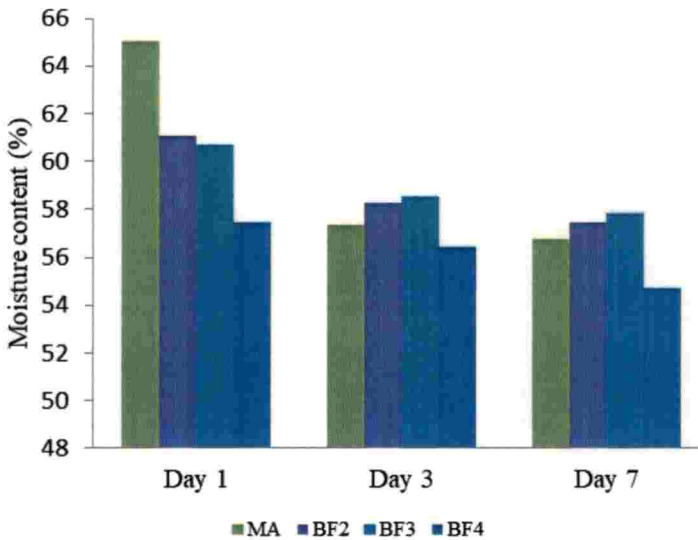

Fig. 4.34 Changes in moisture content of different bunds at Ponnani *kole*

216



Of the bundles formed at the Ponnani, the manually formed ones were the moistest throughout the period of observation, losing 11.83 per cent moisture between the first and the third days of observation, indicating a loosely packed bundle. The bundles formed mechanically by BF3 and BF2 showed on par moisture content throughout the period of observation, with the percentage change in moisture content being less from the third to the seventh day, when compared to that from the first to the third day. The bundle formed by BF4 exhibited the least moisture content; thus being indicative of a better moisture removal at the time of bundle making. This may be due to better compaction. However the rate of moisture removal was increased from the third to the seventh, due to drying.

At Tavanur, moisture content of all the different types of bundles was seen to be on par, on the day of formation (Fig. 4.35). By the third day, reduction in moisture content was observed in the bundles formed by BF4 using the NH3230 tractor, and the bundles formed using BF2 and BF1 operated by KTT. The mechanically formed bundle using BF1 was on par with manually formed bundle in terms of moisture content, while moisture content of those bundles formed using BF3 and BF2 lay between them. By the seventh day, moisture contents of the bundles formed by BF2 and BF1 using KTT were reduced further, probably because of the lesser compaction at the time of formation, and therefore a looser structure which permits easier loss of moisture.

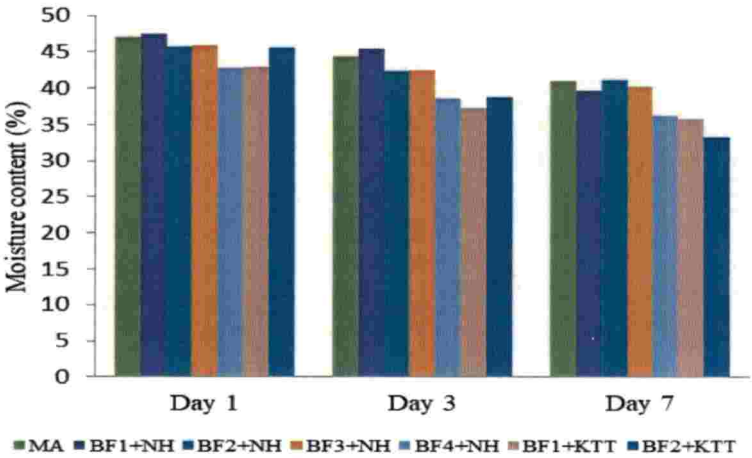

Fig. 4.35 Changes in moisture content of the different bundles at Tavanur

217

In terms of decrease in moisture content, all bunds except those formed by BF2 using NH 3230 tractor were on par. The bunds formed manually were on par with those formed by BF2 using the NH 3230 tractor. In case of the manually formed bunds, and those formed by BF3, BF2 and BF4 using the NH 3230, the rate of change of moisture content decreased as time elapsed. This hinted at a comparatively compact structure with less number of large pores for water to be removed easily. The same is exhibited in bunds formed using BF1 operated by KTT, due probably to the bund's smaller size.

#### 4.5.7 Bulk Density of Formed Bunds

The results of the observations of values of bulk density if the different types of bunds formed are presented in Table 4.75 to 4.77.

Table 4.75 Summary of changes in wet bulk density of the bunds at consecutive intervals at Pullazhi *kole*

Sl. No.	Method of bund formation	Wet bulk density (g cm <sup>-3</sup> )				
		Day 1	Day 3	Day 7	% change	
					D1 to D3	D3 to D7
1	Manual	1.08 <sup>c</sup>	1.05 <sup>c</sup>	1.03 <sup>c</sup>	-2.78	-1.90
2	Mechanically formed – BF1	1.89 <sup>a</sup>	1.85 <sup>a</sup>	1.56 <sup>a</sup>	-2.12	-15.68
3	Mechanically formed – BF2	1.82 <sup>a</sup>	1.64 <sup>b</sup>	1.61 <sup>a</sup>	-9.89	-1.83
4	Mechanically formed – BF3	1.50 <sup>b</sup>	1.47 <sup>b</sup>	1.32 <sup>b</sup>	-2.00	-10.20

Table 4.76 Summary of changes in wet bulk density of the bunds at consecutive intervals at Ponnani *kole*

Sl. No.	Method of bund formation	Wet bulk density (g cm <sup>-3</sup> )				
		Day 1	Day 3	Day 7	% change	
					D1 to D3	D3 to D7
1	Manual	1.45 <sup>c</sup>	1.36 <sup>b</sup>	1.23 <sup>c</sup>	-6.21	-9.56
2	Mechanically formed – BF2	1.75 <sup>b</sup>	1.66 <sup>a</sup>	1.60 <sup>b</sup>	-5.14	-3.61
3	Mechanically formed – BF3	2.00 <sup>a</sup>	1.90 <sup>a</sup>	1.85 <sup>a</sup>	-5.00	-2.63
4	Mechanically formed – BF4	1.99 <sup>a</sup>	1.89 <sup>a</sup>	1.90 <sup>a</sup>	-5.03	0.53

Table 4.77 Summary of changes in wet bulk density of the bunds at consecutive intervals at Tavanur

Sl. No.	Method of bund formation	Wet bulk density (g cm <sup>-3</sup> )				
		Day 1	Day 3	Day 7	% change	
					D1 to D3	D3 to D7
1	Manual	1.49 <sup>b</sup>	1.46 <sup>a</sup>	1.36 <sup>a</sup>	-2.01	-6.85
2	Mechanically formed – BF1+NH 3230	1.15 <sup>c</sup>	1.08 <sup>c</sup>	1.03 <sup>bc</sup>	-6.09	-4.63
3	Mechanically formed – BF2+NH 3230	1.58 <sup>b</sup>	1.32 <sup>b</sup>	1.13 <sup>b</sup>	-16.46	-14.39
4	Mechanically formed – BF3+NH 3230	1.71 <sup>a</sup>	1.54 <sup>a</sup>	1.13 <sup>b</sup>	-9.94	-26.62
5	Mechanically formed – BF4+NH 3230	1.50 <sup>b</sup>	1.43 <sup>ab</sup>	1.39 <sup>a</sup>	-4.67	-2.80
6	Mechanically formed – BF1+KTT	1.05 <sup>d</sup>	1.00 <sup>c</sup>	0.95 <sup>c</sup>	-4.76	-5.00
7	Mechanically formed – BF2+ KTT	1.15 <sup>c</sup>	1.03 <sup>c</sup>	0.94 <sup>c</sup>	-10.43	-8.74

The wet bulk density observations at Pullazhi *kole* indicated that the bunds formed using BF1 and BF2 showed on par values, followed by the bunds formed by BF3 (Fig. 4.36). The wet bulk density of the manually formed bunds was least throughout the period of observation. The percentage change between bulk densities from the first day to the third day and the third day to the seventh day was less in the manually formed bunds, indicating a stabilization tendency, as time passed. In case of the bunds formed by BF2, though there was a greater reduction in the bulk density from the first day to the third day, very little reduction was observed further, again pointing to the bunds becoming stable. A larger rate of change of bulk density was observed in bunds formed by BF3 and BF1; though the bunds formed by BF1 showed a high bulk density.

At Ponnani, the bunds formed by BF3 and BF4 were seen to have the highest bulk density, followed by the bunds formed by BF2 and the manually formed bunds. The differential change observed in the bunds formed by BF4 was

very low from the third to the seventh day and this was highest for the manually formed bunds, indicating that the loosely packed manually formed bunds tended to lose moisture and thus their bulk density easily. Figure 4.37 shows the variation in the wet bulk density over the period of observation in the different types of bund formed.

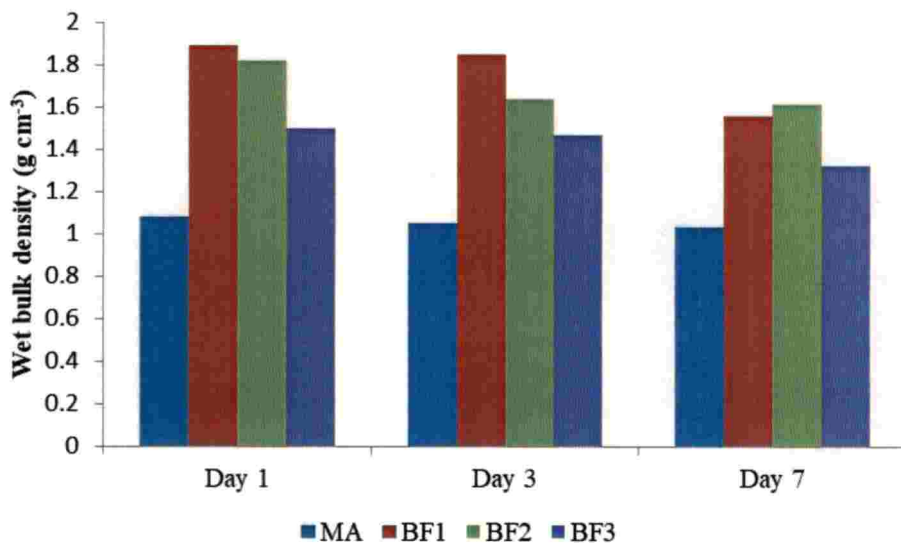

Fig. 4.36 Variation in wet bulk density of bunds formed at Pullazhi kole

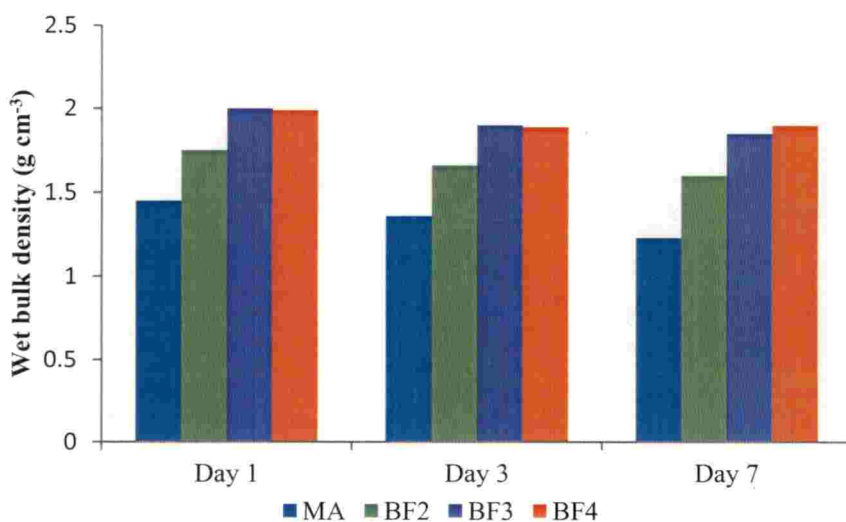

Fig. 4.37 Variation in wet bulk density of bunds formed at Ponnani kole

220

On the first day, at Tavanur, the bulk density of the bunds formed by BF3 – NH3230 combination was the highest but the values decreased considerably from the third to the seventh day of observation. The bulk densities of the bunds formed by BF2 and BF4 using NH3230 tractor were on par with the manually formed bunds. This was followed by the bunds formed by BF1-NH3230, and BF2- KTT, with the bunds formed using BF1 – KTT combination having the least bulk density.

As time elapsed, the bulk density of manually formed bunds increased and was the highest and on par with bunds formed by BF4. The bunds formed using BF2 and BF1-KTT and BF1- NH3230 combination were on par. The least rate of change in bulk density was observed in bunds formed by BF4 while the greatest change was observed in bunds formed by BF2-NH3230 combination. The lesser clay content contributed to less void space and as the bunds lost moisture, the bulk density was also reduced. The changes in wet bulk density are expressed in Fig. 4.38.

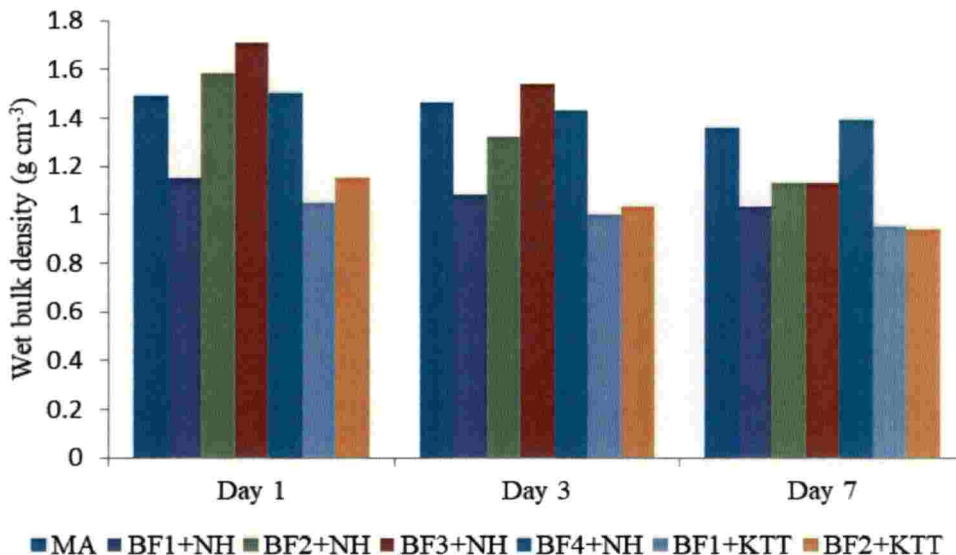

Fig. 4.38 Variation in wet bulk density of bunds formed at Tavanur

#### 4.5.8 Speed of Operation

The speed of operation, when the different bund strengthening implements were operated in the field at the three test locations, was calculated as per Section 3.5.8 and is presented in Table 4.78. The observations are presented in Appendix VI.

Table 4.78 Speed of operation of different bund strengthening implements at three test locations

Sl. No.	Implement	Mean speed of operation (km h <sup>-1</sup> ) ± SE			
		Pullazhi <i>kolepadavu</i>	Kolothumpadam <i>kolepadavu</i>	Tavanur	
				NH 3230	KTT
1	BF1	2.85±0.05	--	2.03±0.01	1.28±0.10
2	BF2	2.74±0.06	2.98±0.01	2.04±0.02	1.24±0.04
3	BF3	2.51±0.03	2.50±0.12	1.89±0.03	--
4	BF4	--	2.67±0.03	1.82±0.03	--

The speed of operation was generally higher for BF1 and BF2 in all soil types. The minimum average speed of operation was observed to be 1.24 km h<sup>-1</sup> when BF1 was operated by KTT at Tavanur, in sandy loam soils.

#### 4.5.9 Draft

The draft of the tractor – implement combination was measured in the field at all test sites, as explained in Section 3.5.9. Ten readings were recorded in each trial and three trials were conducted at each location for determining the maximum, minimum and average draft requirements. These are presented in Appendix - VII.

Figure 4.39 shows the draft requirement for operating the different types of bund strengthening implements, using KTT at Pullazhi *kole* lands.

222

Operation of BF1 using KTT required the least draft, because the volume of wet soil handled is less in this case. The bigger models had a higher draft requirement. The values of draft recorded ranged from 4061.34 N to 4895.19 N for BF1, 3992.67 N to 5326.83 N for BF2 and 4512.6 N to 5670.18 N for BF3.

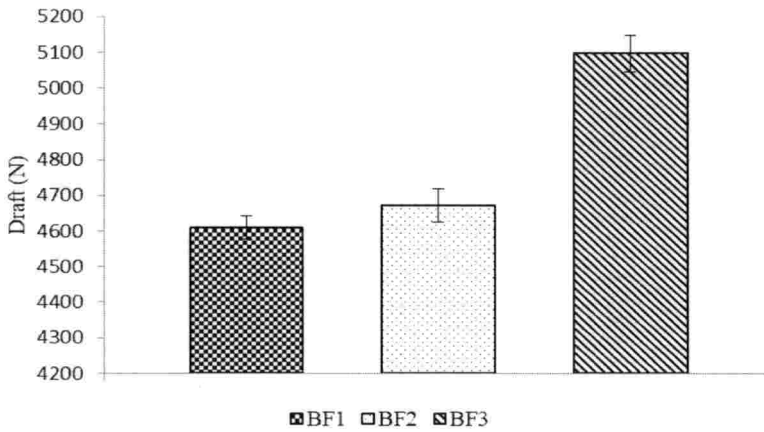

Fig. 4.39 Draft requirement for different bund strengthening implements at Pullazhy kole

At Ponnani kole lands, it was seen that high draft was experienced for both BF3 and BF4 (9574.56 N). BF2 showed a minimum draft of 8416.98 N and a maximum of 8985.96 N. The draft observed in the various trials are plotted in Fig. 4.40.

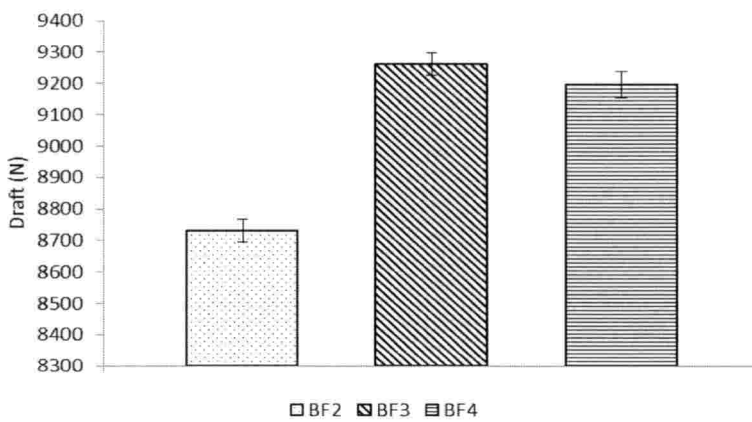

Fig. 4.40 Draft requirement for different bund strengthening implements at Ponnani kole

22

Both KTT and NH 3230 were operated at the fields in Tavanur. The variation in draft among the different mechanical models of the implement when operated by the NH3230 is shown in Fig. 4.41.

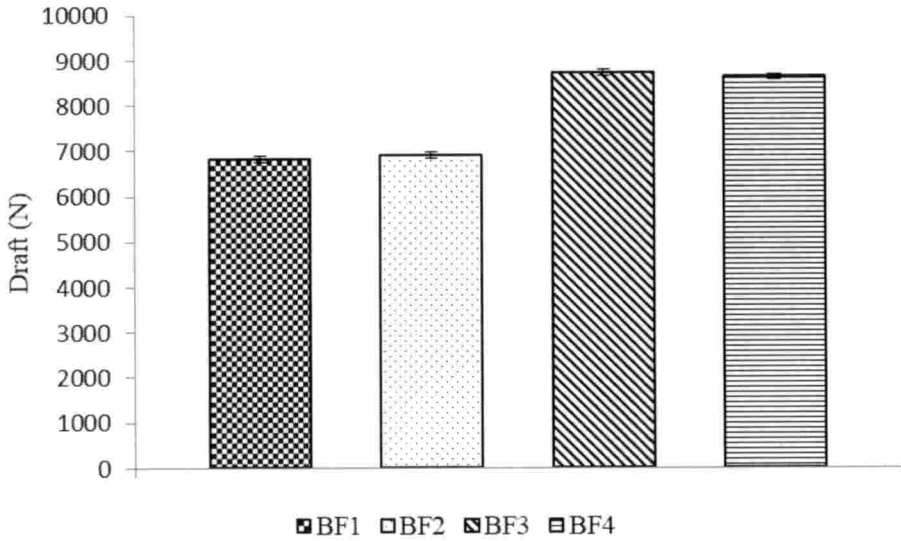

Fig. 4.41 Draft requirement for different bund strengthening implements at Tavanur (Power source: NH 3230 tractor)

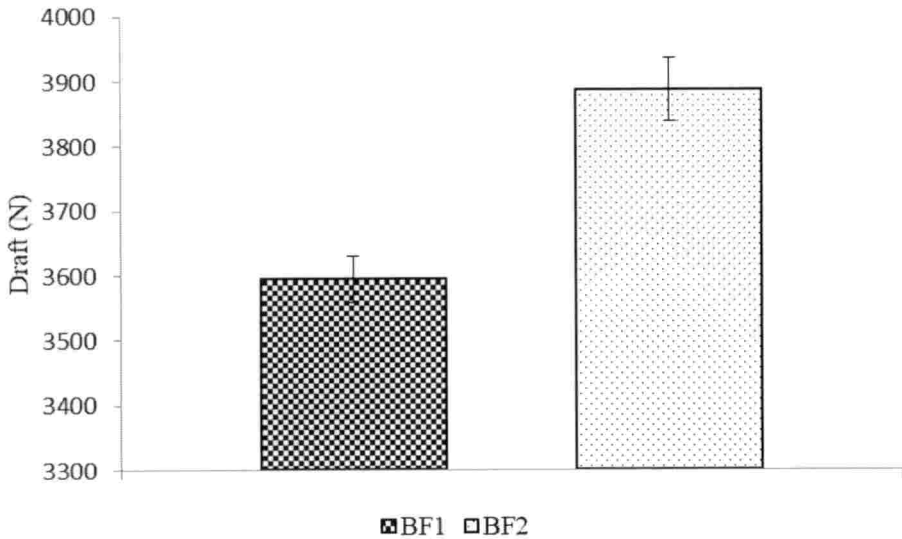

Fig. 4.42 Draft requirement for different bund strengthening implements at Tavanur (Power source: KTT)

220



Figure 4.42 shows the draft required to operate the different mechanical models using KTT in the fields at Tavanur.

The maximum draft of 9456.84 N was observed during operation of BF3 with NH 3230, while the minimum draft obtained for its operation is 8260.02 N with the same power source. BF1 had the least draft requirement in this condition. The variation in the maximum and minimum values of draft was least for both BF3 and BF4. BF3 showed a greater draft, as expected, due to its larger size. As the soil was sandy loam, the draft experienced by the implements was less, when compared to the draft experienced by the same models (with the same power source) in the silty clays of the Pullazhi *kole*. When KTT was used, BF2, which was bigger of the two models tested, indicated a higher draft.

#### 4.5.10 Fuel Consumption

The fuel consumption was measured, as per procedure explained in section 3.5.10, at all the test locations. Three trials were taken at each location. The readings obtained are presented in Table 4.79. The observations are presented in Appendix VIII.

Table 4.79 Fuel consumed by different bund strengthening implements at three test locations

Sl. No.	Implement	Mean fuel consumption (L h <sup>-1</sup> ) ± SE			
		Pullazhi <i>kolepadavu</i>	Kolothumpadam <i>kolepadavu</i>	Tavanur	
				NH 3230	KTT
1	BF1	3.22±0.18	--	2.53±0.08	3.21±0.07
2	BF2	3.27±0.21	3.21±0.04	2.68±0.12	3.31±0.13
3	BF3	3.71±0.11	3.76±0.12	2.84±0.13	--
4	BF4	--	7.71±0.05	5.65±0.32	--

The highest fuel consumption is seen for BF4, as the tractor had to be operated twice to complete the bund formation. Trials in sandy loam soils of

Tavanur showed a lesser fuel consumption, with BF1 requiring the least amount of fuel, when operated using NH 3230. When a similar power source (31.32 kW JD5042) was used at Kolothumpadam *kolepadavu*, BF3 operation recorded the highest average fuel consumption of 3.76 L h<sup>-1</sup>. When operation using KTT was examined, it was seen that in the silty clays of Pullazhi *kole*, the fuel consumption was highest at 3.71 L h<sup>-1</sup> for operating BF3 and was 3.27 L h<sup>-1</sup> for operation of BF2. This was almost similar to the fuel consumed during operation of the said model in the sandy loams of Tavanur (3.31 L h<sup>-1</sup>). The slight increase, irrespective of the type of soil, maybe due to the dynamic soil condition in the field at the time of operation. Several soil properties including the moisture content of the soil at the time of observation, the strength of the underlying layer of soil, may cause a local change in the observed parameter.

#### 4.5.11 Capacity

The capacity of the implement was calculated as explained in Section 3.5.11. The length of bund formed in unit time was noted and the capacity of the implement is expressed in m h<sup>-1</sup>. Three trials were taken at each test location and the average length of bunds formed by the different models are shown in Table 4.80. Appendix IX displays the observations.

Table 4.80 Capacity of the different bund strengthening implements at three test locations

Sl. No.	Implement	Mean capacity (m h <sup>-1</sup> ) ± SE			
		Pullazhi <i>kolepadavu</i>	Kolothumpadam <i>kolepadavu</i>	Tavanur	
				NH 3230	KTT
1	BF1	2854.88±46.29	--	2030.48±11.50	1280.71±101.90
2	BF2	2734.48±62.38	2984.24±5.61	2033.97±18.50	1238.18±39.58
3	BF3	2515.04±25.33	2504.03±123.88	1890.21±30.53	--
4	BF4	--	1334.33±12.24	906.86±14.03	--

The lowest capacity of bund formation was observed in the case of BF4. This was due to the greater amount of time required, as two passes were needed

to complete the bund formation. The KAMCO TeraTrac tractor formed lesser lengths of bunds due to the lesser power and lower speed. The smaller models formed greater length of bunds, probably due to the lesser load acting on the power source and the greater speeds attained. The maximum capacity of 2984.24 m h<sup>-1</sup> was observed for BF2 operated by JD 5042 at Ponnani *kole*. As the volume of soil handled increased in BF3, the speed of operation reduced slightly; which led to slight reduction in the capacity of bund formation.

However, there was a steep increase in capacity (metres of bund formed in unit time) of the implement, in all cases of mechanical bund formation, when compared to manual bund formation. As noted in Section 3.5.11, a manual labourer is able to form only about 62.5 m to 75 m of bund per hour on an average, while the lowest capacity of forming mechanical bunds in the different methods adopted averages at 906.86 m h<sup>-1</sup>. This clearly indicates that the mechanical bund strengthening implements have a superior bund formation capacity as compared to the manual operations.

#### **4.5.12 Wheel Slip**

The wheel slip was calculated as per Section 3.5.12. The wheel slip recorded for the various types of bund strengthening implements at the three test locations are shown in Table 4.81. At each location, three trials were conducted to assess the values of wheel slip, for all the models. Observations are shown in Appendix X.

The wheel slip for the different bund strengthening implements was observed to range from 8.29 to 9.50 per cent at Pullazhi *kolepadavu*, and 11.57 to 13.21 per cent at Kolothumpadam *kolepadavu*, Ponnani. At Tavanur it was seen that values of wheel slip ranged from 5 to 7.44 per cent when NH 3230 was used as power source, while it varied from 6.33 to 8.18 per cent when KTT was used as the power source. The fact that a higher wheel slip was observed in the silty clays when compared to the sandy loams is a corroboration of the results of

several studies. The wheel slip was also found to lie within the acceptable range of 5 to 15 per cent.

Table 4.81 Wheel slip for different bund strengthening implements at three test locations

Sl. No.	Implement	Mean wheel slip (%) ± SE			
		Pullazhi kolepadavu	Kolothumpadam kolepadavu	Tavanur	
				NH 3230	KTT
1	BF1	8.29±0.54	--	5.00±0.00	6.33±0.50
2	BF2	8.91±0.50	11.57±0.64	5.77±0.63	8.18±0.51
3	BF3	9.50±0.13	13.21±0.58	7.44±0.04	--
4	BF4	--	12.02±0.32	6.22±0.02	--

#### 4.5.13 Cost of Operation

The cost of operation of the different bund strengthening implements was performed as explained in Section 3.5.13. Figure 4.43 depicts the cost of formation of 100 m of bund using the different types of bund strengthening implements and compared to the manual method of bund formation.

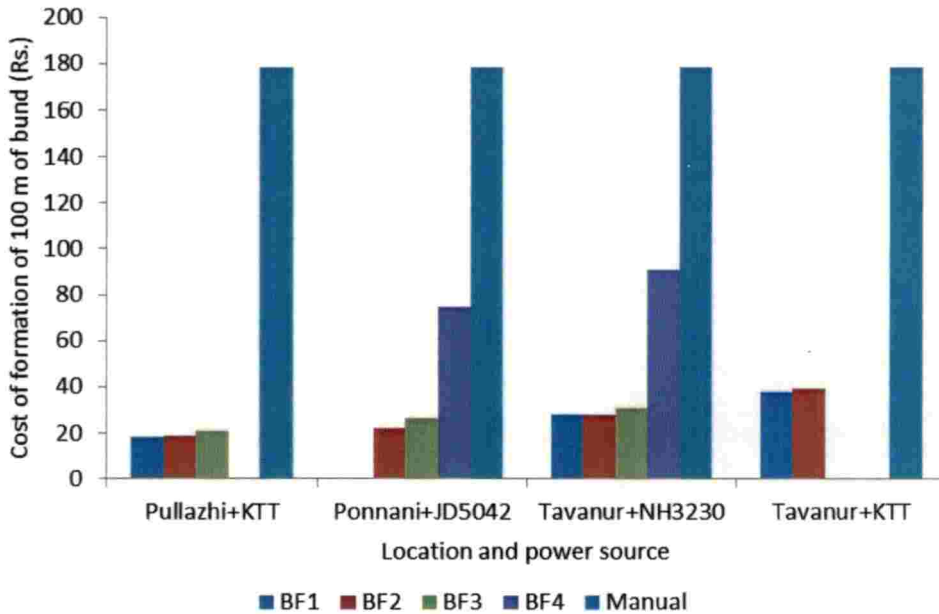

Fig. 4.43 Variation in cost of formation of 100 m of bund using differmt methods

228

The calculation of the cost of operation of the bund strengthening implement is explained in Appendix XI. The cost of formation of 100 m of bunds by the different models of bund strengthening implements is presented in Table 4.82.

Table 4.82 Cost of formation of 100 meters of bund by different methods

Sl. No.	Implement	Cost of bund formation per 100 m(Rs.)			
		Pullazhi (KTT)	Ponnani (JD5042)	Tavanur	
				NH3230	KTT
1	BF1	18.00	--	28.00	38.00
2	BF2	19.00	22.00	28.00	39.00
3	BF3	21.00	26.00	30.00	--
4	BF4	--	75.00	91.00	--

The manual labourers form 375 m to 450 m of bunds per day of 6 hours, at a wage rate of Rs. 800/- to Rs. 850/-, i.e., they form about 62.5 m to 75 m of bunds per hour. The cost of forming bunds manually ranges from Rs. 133/- to Rs. 142/- per hour and approximately Rs. 1.78 to Rs. 2.27 per metre length of bund.

#### 4.5.14 Deformation and Stress Analysis

Deformation and stress analysis of the model BF3 was carried out using the ANSYS 16.0 software. The results are presented in the Fig. 4.44 and Fig. 4.45. The maximum deformation of 8.687 mm was observed at the tip of the gathering board. The stress analysis yielded a maximum equivalent stress of 211.59 MPa at the point connecting the gathering boards to the forming boards. The ultimate tensile stress of the material as per the software is 40 MPa. The factor of safety is calculated as 2.17.

Thus the implement is capable of withstanding stress upto 230 MPa while the maximum stress is analysed as 211.56 MPa and hence it falls in the safe range. However, in future fabrications, the joint can be strengthened, if required. All the other components of the implement lie within safe stress limits.



Fig. 4.44 Deformation analysis using ANSYS 16.0



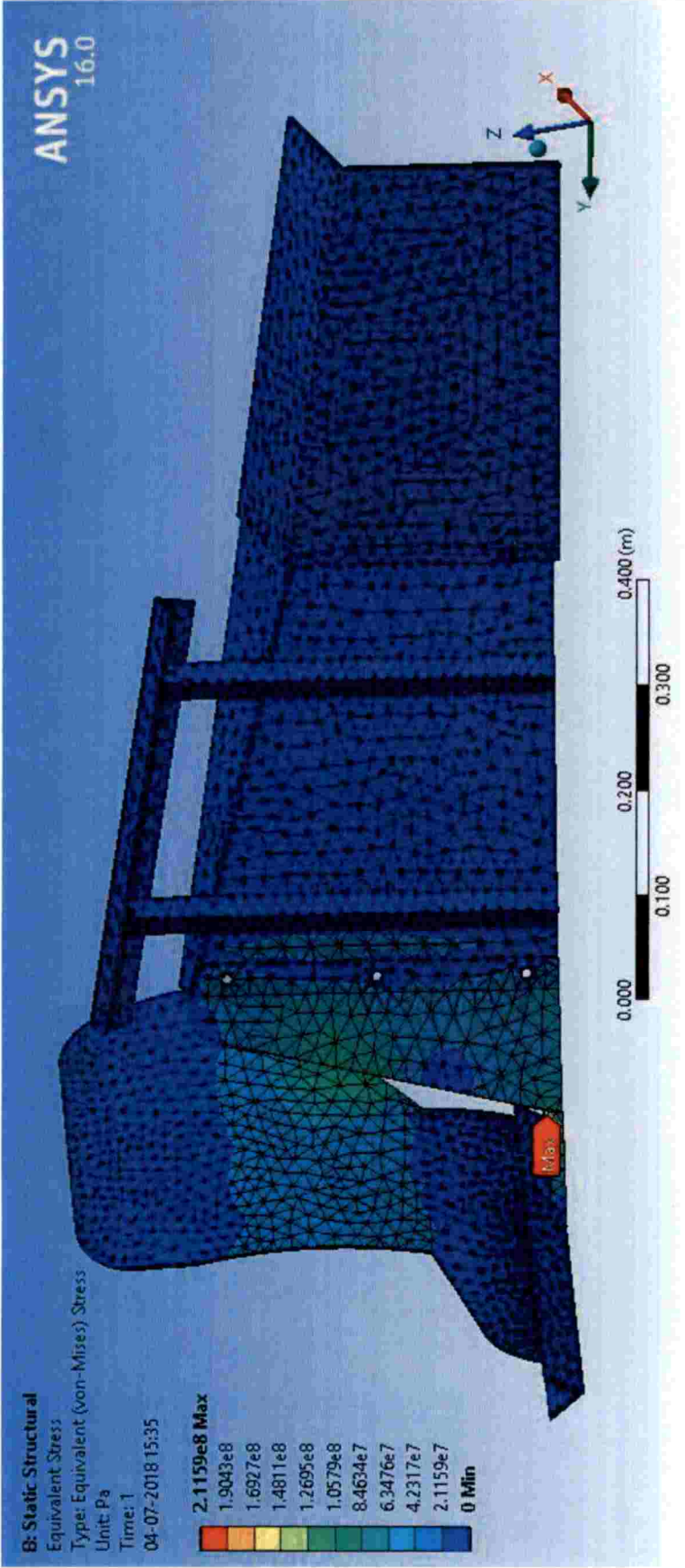

Fig. 4.45 Stress analysis using ANSYS 16.0

231

# *Summary & Conclusion*



## CHAPTER V

### SUMMARY AND CONCLUSION

Mechanical bund strengthening devices are not prevalent in the paddy wetlands of Kerala. Such implements are in great demand by the farmers because they will ease the burden of manual bund formation. This study was conducted with the aim to develop a low cost bund strengthening implement for use in the paddy wetlands, especially the *kole* lands typical to Kerala. This chapter summarises the work done as a part of this study, the major observations noted and conclusions drawn from the various experiments conducted.

Preliminary assessment of the power tiller operated *kaipad* bund former and the KAMCO TeraTrac mini tractor operated KAU bed former was conducted at Pullazhi *kolepadavu* of Thrissur *kole* lands to determine their suitability to paddy wetlands. Both these implements were not suited for use as such. The action of the KAU bed former in gathering soil inwards was found suitable. The KAMCO TeraTrac mini tractor with cage wheels could be used as a power source alternative to the commonly used power tillers. Preliminary soil sampling and assessment of soil properties was also done.

The results of these trials showed the suitability of a forming board type of bund strengthening implement. The first model of the bund strengthening implement was developed based on the bund size requirements observed from farmers' practice. Preliminary testing was conducted in the Pullazhi *kolepadavu* of Thrissur *kole* lands. Modifications were made to this model, based on the results of the preliminary field testing and the soil properties observed. The modified model was tested at two locations, *viz.*, Pullazhi *kolepadavu*, Thrissur *kole* and Kolothumpadam *kolepadavu*, Ponnani *kole*. Soil properties such as moisture content, bulk density, soil texture, consistency limits, penetration resistance and shear strength of the test locations were also studied.

The soils at Pullazhi *kolepadavu* and Kolothumpadam *kolepadavu* were silty clay, while the soil at Tavanur was sandy loam in texture. The moisture

content averaged at 54.97 per cent at Pullazhi, 65.84 per cent at Ponnani and 47.00 per cent at Tavanur. For the same order of the locations, the wet bulk density values were 1.49, 1.85 and 1.79 g cm<sup>-3</sup>, the liquid limit values were 60.92, 68.60 and 31.92 per cent, the plastic limit values 44.60, 44.42 and 18.75 per cent and the shrinkage limit values were 12.19, 10.08 and 21.48 per cent respectively. The penetration resistance as indicated by cone index increased with depth. It varied from 1.45 kg cm<sup>-3</sup> at a depth of 7.5 cm from the soil surface to 5.90 kg cm<sup>-3</sup> at a depth of 30.0 cm, at Pullazhi. At Ponnani the same was observed to range from 0.20 to 6.46 kg cm<sup>-3</sup> and at Tavanur these values were 1.58 to 11.43 kg cm<sup>-3</sup>. The shear strength values were observed at depths of 20, 40 and 60 cm from the soil surface and these ranged from 23.44 to 54.70 to 13.89 kPa respectively at Pullazhi. At Ponnani, these values were 16.5, 74.67 and 88.57 kPa and at Tavanur the values were 26.92, 48.62 and 54.70 kPa respectively. The soils of Pullazhi and Ponnani *kole* had a high organic content (5.42 to 6.33 per cent, and 5.95 to 6.28 per cent, respectively) while the soils at Tavanur had only medium organic matter content.

Based on the preliminary trials, three models of bund strengthening implement – BF1, BF2 and BF3 - were fabricated to make bunds with a trapezoidal cross section in the paddy fields. The main parts of the implement were the MS angle tool frame and hitch assembly of size 1150 x 500 mm, implement frame made of MS angle to connect the forming board assembly to the tool frame, modified forming boards with gathering boards attached in the front, and a 400 mm long, three sided forming case at the rear which provided a plastered finish to the formed bund. All the elements, including the forming boards and the forming case, acted like a single unit. The top width, bottom width and rear height of the developed models of the bund strengthening implement are as follows:

Model I - BF1 – 150, 250 and 150 mm respectively

Model II – BF2 – 200, 350 and 150 mm respectively

Model III – BF3 – 250, 400 and 250 mm respectively

The developed models of the bund strengthening implement was tested at the two *kole* paddy fields - Pullazhi *kolepadavu*, Thrissur *kole* and Kolothumpadam *kolepadavu*, Ponnani *kole* - and one non-*kole* paddy field at Athalur, Tavanur.

The initial testing revealed the unsuitability of KAMCO TeraTrac (as power source) and the model BF1 of the bund strengthening implement in Ponnani *kole*. Hence 11.5 kW KAMCO TeraTrac was used as power source in Pullazhi *kole*, 31.32 kW John Deere 5042 was used in Ponnani *kole* and both the KAMCO TeraTrac and 31.32 kW New Holland 3230 were used in Tavanur fields. A trial of a combined operation of the model BF2 over bunds formed by BF3 was also performed at Ponnani and Tavanur. A low cost profile measuring instrument was also developed to measure the profile of the bunds formed in the fields by the different models of the implement.

The three models of the bund strengthening implement were tested for performance at the three test locations. The shape of the bunds formed by different methods was analysed. The soil properties such as moisture content, bulk density, penetration resistance and shear strength were observed on the bunds formed during operation. Readings were taken on the day of bund formation and the third day and seventh day after bund formation.

Parameters such as speed of operation, draft, fuel consumption, capacity of the implement and wheel slip were also noted and the cost of operation was calculated. The ANSYS 16.0 software was used to determine the deformation and stress limits for the biggest model, *viz.*, BF3.

The major conclusions arising in the study are read below:

- The KAMCO TeraTrac mini tractor with cage wheels can be used as a power source in the Pullazhi *kolepadavu* for operating the bund strengthening implement. It provides better traction than the power tiller,

is easy to manoeuvre and thereby maintain direction, and reduces the drudgery of the operator.

- KAMCO TeraTrac mini tractor cannot be recommended for operation in the Ponnani *kole* lands as the depth of soft soil in these fields ranged from 300 to 600 mm and the tractor could not develop traction for movement. It performed well in the sandy loam soil at Tavanur.
- A forming board type of bund strengthening implement was suitable for the bund strengthening operations in the *kole* lands.
- The varying sizes of manually formed bunds according to farmers' practice at different locations makes it difficult to develop a single unit to suit all the field bund dimensions.
- The three models developed in the study were suited to the *kole* lands with silty clay soils. They could also be used in sandy loam soil to form bunds.
- The dimensions of the mechanically formed bunds were bigger than those of the manually formed bunds at Pullazhi. The mechanically formed bunds exhibited a better height, top width and bottom width during the time period of observation. Of the mechanically formed bunds, those formed by the model BF3 were the biggest. The mechanical bunds were more compact and stable.
- At Ponnani, the bunds formed by BF3 had the maximum values for bottom width, top width and height throughout the period of observation. The bunds formed by the BF4 trial also exhibited better shape retention. The bunds formed by BF3 and BF4 showed minimum variation in dimensions. Though the manual bunds showed on par or better dimension when compared to BF2, the variation in dimensions of the manual bunds was the greatest.

- In Tavanur the manual bunds had the highest dimensions, as the farmers made large bunds in the fields. The mechanical devices that have been developed cannot perform the operation of strengthening pre-existing bunds here. They can be used to form new bunds in fields.
- Among the mechanical devices, bunds formed by BF3 and BF4 showed lower variation in bund dimensions when operated by NH 3230. These bunds showed better packing of soil. When KTT was used as power source, the height of bunds formed by BF2 were seen to be on par with those formed by BF4-NH 3230. However, the greater height reduction in bunds formed by KTT points to insufficient compaction, probably due to the lower power. The bunds formed by BF3 had the highest dimensions among mechanical implements.
- The profile measuring instrument could successfully plot the profiles of the bunds that were constructed in the field.
- The values of the cone index increased, along the depth of the bunds and at the time intervals considered, in all cases, at all test locations.
- The values of cone index are higher for mechanically formed bunds at all depths, when compared to the manually formed ones at Pullazhi. Among the mechanically formed bunds, the cone index values of the bunds formed by BF3 were higher at greater depths; which may be due to that fact that as the bunds are formed over the pre-existing ones, the remnants of the compacted soil from the previous season are present at the bottom of the bund and add to the value of the cone index. The resistance offered by manually formed bunds is least, indicating their lower strength. The strength of bunds as indicated by the cone index values increased as with the passage of time also.
- Differential responses, due to the interaction of the different methods of the bund formation over the period of observation, were observed from a

depth of 12.5 cm onwards in the bunds formed at Pullazhi. This indicated a significant variation in the strength of the bund in all processes of bund formation.

- At Pullazhi *kole* fields, of the mechanical bund strengthening implements used, BF1 and BF2 showed a better performance in terms of strength measured as cone index.
- At Ponnani, the cone index values were higher for all mechanically formed bunds. BF4 showed higher values of cone index due to the increased force exerted on top of the bund due to two passes of the mechanical implements on the same bund.
- The manual bunds had lower values of cone index and thus were less strong in comparison to the mechanically formed ones on the day of formation at Ponnani. As time progressed, the strength of the top layers increased and were very near the values for the bunds formed mechanically. But as depth increased these values showed a comparative decrease, which may be due to the lesser compaction offered to the bunds in the process of manual bund formation. The increase in cone index values of the top layers with passage of time was due to the drying up of top layers. The bunds formed by BF3 and BF4 exhibited higher values for cone index over the different depths as time progressed.
- Differential responses were observed from a depth of 12.5 cm onwards indicating greater variability in values of cone index at Ponnani also. Relative changes in cone indices were less in the case of BF4 (D1 to D3) and BF3 (D3 to D7). The performance of BF3 and BF4 gave the best results.
- At Tavanur, the manually formed bunds showed the highest cone index values. Among the mechanically formed bunds, with NH 3230 as the power source, the bunds formed by BF4 exhibited higher values of cone

index. When KTT was used as the power source, bunds formed by BF2 showed comparatively higher values initially.

- The relative changes in cone index were generally uniform. Bunds formed by BF3 had the lowest change with passage of time. The insignificant differential response in cone index is noticed at almost all depths.
- It can be stated that BF2 or BF4, operated by NH 3230, is suitable to the Tavanur fields, in terms of strength of bund as assessed by cone index.
- At Pullazhi, the shear strength values exhibited by the manual bunds were always lesser than that by mechanically formed bunds. The bund formed by BF2 showed the highest value of 46.02 kPa at 0.2 m depth which went upto 40.81 kPa on the seventh day. The same trend was seen in Ponnani also but the bunds formed by BF3 and BF4 had the highest shear strength values. At Tavanur, on the day of bund formation, the bunds formed by BF4 had the highest shear strength of 19.10 kPa at 0.2 m depth but by the seventh day all mechanically formed bunds showed on par values and the manual bund strengthened and showed the highest value of 17.36 kPa. At 0.4 m also the trend for the first day was similar and the mechanically formed bunds were on par and greater than the manual bunds. By seventh day, the models BF2 and BF3 showed increased shear strength values. At depths of 0.6 m the manual bunds showed higher values by the seventh day (56.44 kPa), indicating stabilisation and formation of strong bunds. With KTT, BF2-formed bunds had higher shear strength at 0.2 m while at 0.4 and 0.6 m the manual bunds exhibited a larger value.
- Lesser moisture content was observed over time for the bunds formed at Pullazhi by BF1 (54.29 per cent on D1 to 45.97 per cent on D7) and BF2 (from 53.70 per cent on D1 to 49.62 per cent on D7). At Ponnani, the bunds formed by BF4 had least moisture content (57.44 per cent on D1 to 54.69 per cent on D7). This indicates a better packing or squeezing action. The BF4-NH 3230 and BF1 – KTT bund formation resulted in bunds with

lesser and on par moisture contents at Tavanur (42.79 per cent on D1 to 36.26 per cent on D7 and 42.95 per cent on D1 to 35.86 per cent on D7 respectively). The moisture content of manually formed bunds was higher.

- Bulk density values at Pullazhi indicated on par packing of bunds by BF1 and BF2. At Ponnani the BF3 and BF4 bunds exhibited higher values. The manual bunds showed the lowest values in both locations. But at Tavanur manually formed bunds show higher bulk density by the seventh day of observation. Of the mechanically formed bunds, those formed by BF4 exhibited a lower rate of change in bulk density with time and these were on par with the manual bunds.
- The higher speed of operation was noticed for BF1 and BF2 in all soil types. The average speed of operation ranged from minimum of  $1.24 \text{ km h}^{-1}$  when BF1 was operated by KTT at Tavanur, in sandy loam soils to  $2.98 \text{ km h}^{-1}$  when BF2 was operated by JD 5042 at Ponnani.
- Draft was least for BF1 operated by KTT and highest for BF3 and BF4 operated in Ponnani silt-clay. The draft was less generally for the sandy loam soil at Tavanur while higher for silty clays.
- The fuel consumption was more in silty clays when compared to sandy loam soil. The minimum fuel consumption was noted as  $2.53 \text{ L h}^{-1}$  for BF1-NH 3230 combination at Tavanur while the maximum was  $3.76 \text{ L h}^{-1}$  for BF3-JD 5042 at Ponnani. The BF4 trials had higher consumption of  $7.71 \text{ L h}^{-1}$  in silty clay at Ponnani and  $5.62 \text{ L h}^{-1}$  in sandy loam at Tavanur.
- The maximum capacity of  $2984.24 \text{ m h}^{-1}$  was observed for BF2 operated by JD 5042 at Ponnani *kole*. At Pullazhi and Tavanur (with NH 3230) BF1 and BF2 had higher capacities. BF4 had lower capacities as two passes of the tractor were required to complete the operation.



- The minimum capacity of mechanical bund strengthening implement is  $906.86 \text{ m h}^{-1}$  and is much higher than the manual bund forming operation ( $62.5 \text{ m h}^{-1}$ )
- Wheel slip is within the acceptable range of 5 – 15 per cent.
- The cost of mechanical formation of bunds ranges from Rs. 18/- to Rs. 30/- per 100 m. For the operation with BF4 it increases to Rs. 75/- and Rs. 91/- at Ponnani and Tavanur respectively. The cost of forming 100 m of bunds manually ranges from Rs. 178/- to Rs. 227/-. Thus there is considerable savings in cost of bund formation, when the mechanical bund strengthening implements are used.
- The developed implement was capable of withstanding stresses arising in the field and had a FOS of 2.17.

**Future works to be undertaken:**

- The bund strengthening implement may be modified to permit better operational efficiency in fields which have level differences.
- The junction where perpendicular field bunds meet cannot be formed using the developed model. The bunds at the junction have to be finished manually. Necessary modifications to avoid this manual finishing of bunds at bund junctions can be made to further reduce the manual labour component.
- The implements can also be suitably modified to allow forming bunds at the boundaries of canals.



## *References*

## REFERENCES

- Abdullahi, M.A.M., Al Jaroudi, A., Al Hall, K. and Ali, N.B. 2015. Determination of suitability of Al-Hassa clay as a road layer through mechanical stabilization. *Electr. J. Geotech. Eng.* 20: 5213-5222. Available: <http://www.ejge.com/2015/Ppr2015.0458ma.pdf>. [09 Jan 2017]
- Agodzo, S.K. and Adama, I. 2004. *Bulk density, cone index and water content relations for some Ghanaian soils* (No. INIS-XA-989). Available: [http://www.iaea.org/inis/collection/NCLCollectionStore/\\_Public/38/100/38100098.pdf](http://www.iaea.org/inis/collection/NCLCollectionStore/_Public/38/100/38100098.pdf)
- Ahaneku, I.E., Oyelade, O.A. and Faleye, T. 2011. Comparative field evaluation of three models of a tractor. *Proceedings of Nigerian Branch of the International soil tillage Research Organization (ISTRO)*:90-98.
- Alattas, R. 2014. Postuino: Bad posture detector using Arduino. *Int. J. Innovation Sci. Res.* 3(2): 208-212.
- Al-Khafaji, A.W.N. and Andersland, O.B. 1992. Equations for compression index approximation. *J. Geotechnological Eng.*, 118(1), pp.148-153.
- Allmaras, R.R., Burwell, R.E., Larson, W.E. and Holt, R.E. 1966. Total porosity and random roughness of the inter row zone as influenced by tillage. *USDA Conserv. Res. Rep.* 7, pp.1-22.
- Ananthi, C., Azha, P. and Manikandan, N. 2014. Agriculture land maintains by Arduino. *Int. J. Sci. Res. Dev.* 2(5): 845-846.
- Ani, A.O., Mbajiorgu, C.C., Akubuo, C.O. and Onwualu, P.A., 2011. Proctor cone penetrometer for in-situ soil strength studies in Nigeria. *Int. J. Agric. Biol. Eng.* 4(3): 16-25.
- Ankit, V., Patel, J. and Vaghela, S. 2016. Obstacle avoidance robotic vehicle using ultrasonic sensor, Android and Bluetooth for obstacle detection. *Int. Res. J. Eng. Technol.* 2(3): 339-348.

Anonymous. 2017(a). IndiaStat [Online]. Available: <https://www.indiaagrstat.com/table/agriculture-data/2/global-comparison-with-india-of-rice/973612/1122069/data.aspx>

Anonymous. 2017(b). IndiaStat [Online]. Available: <https://www.indiaagrstat.com/table/agriculture-data/2/global-comparison-with-india-of-rice/973612/1122396/data.aspx>

Arvidsson, J., Keller, T. and Gustafsson, K. 2004. Specific draught for mouldboard plough, chisel plough and disc harrow at different water contents. *Soil Tillage Res.* 79(2): 221-231.

ASABE Standards, 2011a. S313.3. Soil Cone Penetrometer. ASABE, St. Joseph, MI.

ASABE Standards, 2011b. EP542. Procedures for Using and Reporting Data Obtained With the Soil Cone Penetrometer. ASABE, St. Joseph, MI

ASAE Standard, 1983. Uniform Terminology for Traction of Agricultural Tractors, Self-Propelled Implements, and Other Traction and Transport Devices (S296. 2), ASABE Standards, St Joseph, MI.

ASAE, 1999. Soil Cone Penetrometer (ASAE S313.3 FEB99), ASAE Standards 2000, pp. 831–833.

ASAE. 1999. Agricultural Machinery Management Data (ASAE D497.4 MAR99), ASAE Standards 2000, pp. 350-357.

ASTM D2573 / D2573M-15e1, Standard Test Method for Field Vane Shear Test in Saturated Fine-Grained Soils, ASTM International, West Conshohocken, PA, 2015, [www.astm.org](http://www.astm.org)

Ayers, P.D. and Perumpral, J.V. 1982. Moisture and density effect on cone index. *Trans. ASAE.* 25(5), pp.1169-1172.

- Bach, T.H., Leon, H., Mark, P. and Otis, W. 2012. The testing and design of an arduino microcontroller board for the study of proxemics. *Univ. South Florida St. Petersburg Student Research Journal*, 2(1): 1-6.
- Bachmann, J., Contreras, K., Hartge, K.H. and MacDonald, R. 2006. Comparison of soil strength data obtained in situ with penetrometer and with vane shear test. *Soil Tillage Res.* 87(1): 112-118.
- Barbier, E.B., Acreman, M., and Knowler, D. 1997. Economic value of wetlands: a guide for policy makers and planners. Gland, Switzerland: Ramsar Convention Bureau
- Bédard, Y., Tessier, S., Laguë, C., Chen, Y. and Chi, L. 1997. Soil compaction by manure spreaders equipped with standard and oversized tires and multiple axles. *Trans. ASAE.* 40(1), pp.37-43.
- Bernik, R. and Vučajnik, F. 2008. The effect of cultivator/ridger type on the physical properties of ridge, power requirement and potato yield. *Irish J. Agric. Food Res.* 47: 53-67.
- Bjerkan, J.A. 1947. The precision planting equipments. *J. Agric. Eng.* 28(4): 54-57
- Brennenstul, M, Bilczyk, W., Cudzik, A., and Czarnecki, J. 2015. Analysis of the power transmission in the tractor wheel – farming ground system. *Agric. Eng.* 4(156): 15-24. doi: [http:// dx.medra.org/ 10.14654/ ir.2015.156.147](http://dx.medra.org/10.14654/ir.2015.156.147)
- Busscher, W.J., Edwards, J.H., Vepraskas, M.J. and Karlen, D.L. 1995. Residual effects of slit tillage and subsoiling in a hardpan soil. *Soil and Tillage Research*, 35(3), pp.115-123.
- Camp, C.R. and Lund, Z.F. 1968. Effect of mechanical impedance on cotton root growth. *Trans. ASAE.* 30(4): 188-190.

- Chandramohanan, K.T. and Mohanan, K.V. 2011. Rice cultivation in the saline wetlands of Kerala-an overview. *Published in Gregor Mendel Foundation Proceedings*, pp.7-12.
- Cowardin, L.M., Carter, V., Golet, F.C. and LaRoe, E.T. 1979. *Classification of wetlands and deepwater habitats of the United States*. US Department of the Interior, US Fish and Wildlife Service.
- Daddow, R.L. and Warrington, G. 1983. *Growth-limiting soil bulk densities as influenced by soil texture* (p.17). Fort Collins, CO: Watershed Systems Development Group, USDA Forest Service.
- Devika, S.V., Khamuruddeen, Khamurunnisa and Jayanth, T. 2014. Arduino based automatic plant watering system. *Int. J. Adv. Res. Comp. Sci. Software Eng.* 4(10): 449 – 456.
- Dhawale, V.R. and Harle, S.M. 2016. Influence of Different Soil Properties on Shear Strength of Soil: A Review. *Am. J. Appl. Sci. Res.* 2(6): 87-90. doi: 10.11648/j.ajasr.20160206.19
- Dixit, A., Khurana, R., Verma, A., Singh, A. and Manes, G.S. 2018. Development and Evaluation of a Wide-Bed Former for Vegetable Cultivation in Controlled Tractor Traffic. *J. Inst. Eng.(India):Series A*, pp.1-4.
- El-Ashry, A.S., El-Shal, A.M., and Radwan, G. G. 2009. Effect of mechanical planting with ridger-seeder on lentil production. *Misr J. Agric. Eng.* 26:1054-1067
- Fathollahzadeh, H., Mobli, H., Rajabipour, A., Minaee, S. Jafari, A, and Tabatabaie, S.M.H. 2010. Average and instantaneous fuel consumption of Iranian conventional tractor with moldboard plow in tillage. *ARPN J. Eng. Appl. Sci.* 5(2): 30-35
- Fernandes, J.A., Duarte, M.L.M. and Eduardo, A.C. 2007. An FTA based methodology for the determination of fuel consumption variation of

tractors. *Proceedings of COBEM 2007 19<sup>th</sup> International Congress of Mechanical Engineering*, November 5-9, 2007, Brasilia, DF.

- Gammoh, I.A. 2011. Double furrow with raised bed - A new improved mechanized water-harvesting technique for large-scale rehabilitation of arid rain-fed areas. *Soil Tillage Res.* 113(1): 61-69.
- Gill, W.R. and Vanden Berg, G.E.V. 1967. *Soil dynamics in tillage and traction* (No. 316-317). Agricultural Research Service, US Department of Agriculture.
- GOK [Government of Kerala]. 2016. Economic Review 2016 [on-line]. Available:[http://spb.kerala.gov.in/EconomicReview2016/web/Chapter02\\_03.php](http://spb.kerala.gov.in/EconomicReview2016/web/Chapter02_03.php) [06 July 2018].
- GOK [Government of Kerala]. 2017. Economic Review 2017 [on-line]. Available: [http://spb.kerala.gov.in/ER2017/web\\_e/ch21.php?id=2&ch=21](http://spb.kerala.gov.in/ER2017/web_e/ch21.php?id=2&ch=21) [09 July 2018].
- Hariansyah, M., Setiawan, R.P.A., Desrial, Made, D.S. and Asep, S. 2014. The application of ultrasonic sensor and Atmega 328 Arduino to measure the ploughing depth elevation of drainage channel. *Int. J. Sci. Res.* 3(8):174-180.
- Harral, B.B. and Cove, C.A.1982. Development of an optical displacement transducer for the measurement of soil surface profiles. *J. Agric. Eng. Res.* 27(5)
- Hegazy, R. 2013. Soil surface profile computation using portable profile meter with image processing and tracking technique. *Global J. Res. Eng.*13(3): 1-6.
- Hillel, D. 1980. *Fundamentals of soil physics*. Academic press, New York. 407p.

- IS - 2720 (Part XXIX). 1975 (Reaffirmed 2005). Indian Standard Methods of test for soils Part XXIX. Determination of dry density of soils in place by the core-cutter method. Bureau of Indian Standards, New Delhi.
- IS - 2720 part V. 1985. Indian standard Method of test for soils. Determination of liquid and plastic limit. Bureau of Indian standards New Delhi.
- IS - 2720 part VI. 1972. Indian standard Method of test for soils. Determination of Shrinkage factor. Bureau of Indian standards, New Delhi.
- IS - 9164. 1979 (Reaffirmed 2002). Guide for estimating cost of farm machinery operation. Bureau of Indian standards, New Delhi.
- Islam, M.A., Badhon, F.F., Anik, M.K.A. and Abedin, M.Z. 2016. Effect of fine content on shear strength of sand. Proc. Of 3<sup>rd</sup> Int. Conference on Advances in Civil Engineering, 21-23 December, 2016, CUET, Chittagong, Bangladesh, Islam, Imam, Ali, Hoque, Rahman and Haque (eds.)
- Jaiswal, P. C. 2006. Soil, Plant and Water Analysis. Kalyani Publishers, New Delhi, pp: 11-15.
- Jamaluddin, A., Fita, L., Dwi, T.R. and Lita, R. 2015. Simple method for non-contact thickness gauge using ultrasonic sensor and android smartphone. *Indonesian J. Elect. Eng.* 15(1): 191-196.
- James, S.P. 1991. Design development and evaluation of a power tiller operated bed former. M.Tech (Agric. Eng.) thesis, Kerala Agricultural University
- Jebur, H.A. and Alsayyah, Y.A. A. 2017. Study of the Soil Moisture Content and the Tractor Speed on the Performance Efficiency of the Machinery Unit. *IOSR J. Agric. Vet. Sci. (IOSR-JAVS)*, e-ISSN: 2319-2380, p-ISSN: 2319-2372. 10 (5): 65-70.



- Jena, S.P., Shanaz, A. and Rupanita, D. 2015. Computerized green house data acquisition system using arduino with LabVIEW. *Int. J. Adv. Res. Electr., Electr. Instrum. Eng.* 4(4): 2350-2357.
- Johnkutty, I. and Venugopal, V.K. 1993. *Kole Lands of Kerala*. Kerala Agricultural University, Vellanikkara, Thrissur, 68p
- Kepner, R.A., Bainer, R. and Barger, E.L., 1990. *Principles of farm machinery* (4<sup>th</sup> Ed.), Avi Pub. Co., Westport, Connecticut.
- Khalilian, A., Garner, T.H., Musen, H.L., Dodd R.B. and Hale, S.A. 1988. Energy for conservation tillage in coastal plain soils. Paper/ASAE, 86:1015
- Kornecki, T.S., Fouss, J.L. and Prior S.A. 2008. A portable device to measure soil erosion/ deposition in quarter-drains. *Soil Use Mgmt.* 24: 401-408.
- Kuipers, H. 1957. A reliefmeter for soil cultivation studies. *Netherlands J. Agric. Sci.* 5: 255-262.
- Kumar, A., Chen, Y. and Rahman, S. 2006. Soil cone index estimation for different tillage systems. In *ASABE/CSBE North Central Intersectional Meeting* (p.1). American Society of Agricultural and Biological Engineers.
- Kumar, A., Chen, Y., Sadek, M.A.A. and Rahman, S. 2012. Soil cone index in relation to soil texture, moisture content, and bulk density for no-tillage and conventional tillage. *Agric. Eng. Int.: CIGR J.* 14(1): 26-37.
- Kurt, K., Joseph, A., Nick, D. and Charles, F. 2008. A low-cost laser distance sensor. *Inst. Electr. Electr. Eng.:* 3002-3008.
- Leema T.G. 2015. An economic analysis of kole cultivation in Kerala with special reference to Thrissur District. Ph. D (Economics) thesis, Mahatma Gandhi University, Kottayam, 269p.

- Lin, J., Sun, Y. and Lammers, P.S. 2014. Evaluating model-based relationship of cone index, soil water content and bulk density using dual-sensor penetrometer data. *Soil Tillage Res.* 138: 9-16.
- Liu, T.K. and Thornburn, T.H. (1963). *Investigations of surficial soils*. ASTM Specification Technical Publication No. 351, p.44.
- Manoj, H.G. and Udupa, N.G.S. 2015. Application of soil moisture sensor in mixed farming. *Int. Res. J. Eng. Technol.* 2(4): 311-314.
- Manuwa, S.I. and Ademosun, O.C. 2007. Draught and Soil Disturbance of Model Tillage Tines under Varying Soil Parameters. *Agric. Eng. Int.: CIGR Journal* [e-journal] 9, Manuscript PM 06 016. Available: <https://ecommons.cornell.edu/handle/1813/10703> [2 May 2017].
- Manuwa, S.I. and Olaiya, O.C. 2012. Evaluation of shear strength and cone penetration resistance behavior of tropical silt loam soil under uni-axial compression. *Open J. Soil Sci.* [e-journal] 2(2). Available: [https://file.scirp.org/pdf/OJSS20120200003\\_92734610.pdf](https://file.scirp.org/pdf/OJSS20120200003_92734610.pdf). [http:// dx. doi. org/10.4236/ojss.2012.22014](http://dx.doi.org/10.4236/ojss.2012.22014) [23 April 2017].
- Marathe, R., Amruta, K. and Utkarsha, D. 2014. Portable automatic height detector. *Int. J. Sci. Eng. Technol. Res.* 3(10): 2693-2698.
- Mari, I.A., Ji, C., Chandio, F.A., Arslan, C., Sattar, A. and Ahmad, F. 2015. Spatial distribution of soil forces on moldboard plough and draft requirement operated in silty-clay paddy field soil. *J. Terramech.* 60:1-9
- Mohammad, T. 2009. Using ultrasonic and infrared sensors for distance measurement. *Int. J. Mech. Aerospace, Industr. Mechatronic Manufacturing Eng.* 3(3): 267-272.
- Monisha, S., Rajeev, R. and Luthra, S.K. 2015. Design and development of smart ultrasonic distance measuring device. *Int. J. Innovative Res. Electr. Commun.* 2(3): 19-23.

- Mouazen, A.M. and Ramon, H. 2002. A numerical–statistical hybrid modelling scheme for evaluation of draught requirements of a subsoiler cutting a sandy loam soil, as affected by moisture content, bulk density and depth. *Soil Tillage Res.* 63(3-4):155-165.
- Mulqueen, J., Stafford, J.V. and Tanner, D.W. 1977. Evaluation of penetrometers for measuring soil strength. *J. Terramech.* 14(3): 137-151.
- Mustapha, B., Aladin, Z. and Rezaul Begg. 2013. Ultrasonic and infrared sensors performance in a wireless obstacle detection system. *Inst. Electr. Electr. Eng.* : 439-444.
- Naderloo, L., Alimadani, R., Akram, A., Javadikia, P. and Khanghah, H.Z. 2009. Tillage depth and forward speed effects on draft of three primary tillage implements in clay loam soil. *J. Food Agric. Environ.* 76(3): 382-385.
- Nawale, S.A., Landage, R.S., Sable, H.P., Kadu, V.M., Lende, A.B. and Gharte, L.V. 2009. Performance evaluation of low hp tractor drawn sugarcane earthling-up cum fertilizer applicator suitable for wide row sugarcane crop. *Int. J. Agric. Environ. Biotechnol.* 2(4): 471-475.
- Nkakini, S.O. and Fubara-Manuel, I. 2014. Effects of soil moisture and tillage speeds on tractive force of disc ploughing in loamy sand soil. *European Int. J. Sci. Technol.* 3(4): 157-164.
- Novák, P., Chyba, J., Kumhála, F. and Procházka, P. 2014. Measurement of stubble cultivator draught force under different soil conditions. *Agron. Res.*, 12(1): 135-142.
- Ohu, J.O., Raghavan, G.S.V. and McKyes, E. 1985. Peatmoss effect on the physical and hydraulic characteristics of compacted soils. *Trans. ASAE*, 28(2), pp.420-424
- Ohu, J.O., Raghavan, G.S.V. and McKyes, E. 1988. Cone index prediction of compacted soils. *Transactions of the ASAE*, 31(2), pp.306-0310.

- O'Sullivan, M.F. and Robertson, E.A.G. 1996. Critical state parameters from intact samples of two agricultural topsoils. *Soil Tillage Res.*, 39(3-4), pp.161-173.
- Pathirana P.H.S., Bandara, P.C., Ratnaweera, A.C., Balasooriya, C.P. and Bandara, M.A. 2010. Sustainable Farming through Mechanization: Development of a Bund Making Machine. *Proceedings of International Conference on Sustainable Built Environment (ICSBE-2010)*, Kandy, 13-14 December, 2010; pp:461-467.
- Patil, M.D., Das, B.S. and Bhadoria, P.B. 2011. A simple bund plugging technique for improving water productivity in wetland rice. *Soil Tillage Res.* 112(1): 66-75.
- Patil, V.S. 2016. Design and development of power tiller operated raised bed seed cum fertilizer drill for dry paddy. M. Tech (Agric. Eng.) thesis, Dr. Balasaheb Sawant Konkan Krishi Vidyapeeth, Dapoli, 121p.
- Perumpral, J.V. 1987. Cone penetrometer applications- A review. *Trans. ASAE.* 30(4): 939-944.
- Prabha, M., Seema, M. and Saraswathi. 2015. Distance based accident avoidance system using Arduino. *Int. Res. J. Eng. Technol.* 2(7): 776-780.
- Pushpa, L. and Swati, D. 2014. Soil moisture and temperature sensor based intelligent irrigation water pump controlling system using Arduino. *Am. J. Sust. Cities Soc.* 3(1): 175-183.
- Raghavan, G.S.V., McKyes, E. and Beaulieu, B. 1978. Clay soil compaction due to wheel slip. *Trans. ASAE*, 21(4): 646-649
- Raghavendra, R., Veerangouda, M., Prakash, K., Palled, V., Hiregoudar, S. and Maski, D. 2013. Development and evaluation of ridge planter for cotton. *Karnataka J. Agric. Sci.*, 26(1): 88-91.

- Rajesh, A.N. 2012. Development and testing of tractor operated bed former for seedbed preparation in *kaipad* region. M.Tech (Agric. Eng.) thesis, Kerala Agricultural University, 103p.
- Raju, N.V., Srimurali, M. and Prasad, K.N. 2014. Functional Correlations between Compaction Characteristics, Un-drained Shear Strength and Atterberg Limits. *Journal of Mechanical and Civil Engineering*, 11(3), pp.109-115.
- Ramachandran S. and Jesudas, M.D. 2017. Measurement of Soil Cone Index in Wet Rice Field Soil Using Digital Hand-Held Cone Penetrometer. *Int. J. Agric. Sci.* ISSN: 0975-3710 & E-ISSN: 0975-9107, 9(45): 4757-4762.
- Rangapara D.K., Dabhi K.L. and Makwana A.D. 2017. Comparative Performance of Tractor Drawn Implements Tillage System with Rotavator Tillage System. *Int. J. Agric. Sci.* ISSN: 0975-3710 & E-ISSN: 0975-9107, 9(5): 3742-3748.
- Raper, R.L., Grift, T.E. and Tekeste, M.Z. 2004. A portable tillage profiler for measuring subsoiling disruption. *Am. Soc. Agric. Eng.* 47(1): 23-27.
- Rathnam, C.A., Suresh, K. and Uday, K.V. 2015. Shear Strength Behaviour of Sand Clay Mixture. *Int. J. Innovative Res. Sci. Eng. Technol.* 4(6): 4658-4666.
- Reid, J.T. 1978. *A comparison of the energy input of some tillage tools*. ASAE Paper No. 78-1039, ASAE, St. Joseph, MI 49085
- Robinson, G.W. 1922. A new method for the mechanical analysis of soils and other dispersions. *J. Agri. Sci.* 12:306-321.
- Römken, M.J.M., Singarayar, S. and Gantzer, C.J. 1986. An automated non-contact surface profilemeter. *Soil Tillage Res.* 6: 193–202.
- Roy, S. and Dass, G. 2014. Statistical models for the prediction of shear strength parameters at Sirsa, India. *Int. J. Civil Struct. Eng.* 4(4): 483-498.

- Sahu, R.K. and Raheman, H. 2006. Draught prediction of agricultural implements using reference tillage tools in sandy clay loam soil. *Biosystems Eng.* 94(2): 275-284.
- Saunders, C., Godwin, R.J. and O'Dogherty, M.J. 2000. Prediction of soil forces acting on mouldboard ploughs. In *Fourth International Conference on Soil Dynamics, Adelaide*.
- Sayedahmed, A.A. 2015. Modeling and correlation of soil cone index for bulk density, moisture content and penetration depth levels in a sandy loam soil. *J. Soil Sci. Agric. Eng.* 6(2): 259-273.
- Serrano, J.M. and Peça, J.O. 2008. The forward speed effect on draught force required to pull trailed disc harrows. *Spanish J. Agric. Res.* 6(2): 182-188.
- Serrano, J.M., Peça, J.O., da Silva, J.M., Pinheiro, A. and Carvalho, M., 2007. Tractor energy requirements in disc harrow systems. *Biosyst. Eng.* 98(3): 286-296.
- Sharma, D.N., Kataria, D.P. and Bahl, V.P. 2001. On farm trials of tractor drawn multicrop ridge-furrow and flat bed seeding machine for rain fed and irrigated conditions. *J. Agric. Eng.* 38(1): 24-33.
- Singh, S.P., Solanki, R.C., Singh, M.K., and Singh, K. 2016. Development of tractor operated bund former-cum-packer for increasing resource productivity. *Indian J. Agric. Sci.* 86(9): 1121-1126.
- Sivaperuman, C. and Jayson, E.A. 2000. Birds of kole wetlands, Thrissur, Kerala. *Zoos' Print J.* 15(10): 344-349.
- Smith, G.D., 1964. Soil-temperature regimes their characteristics and predictability. United States Soil Conservation Service
- Smith, V.T. (1966). The development of a modified soil vane shear. Masters Thesis, University of Missouri at Rolla, USA, 5727, 72p. Available: [http://scholarsmine.mst.edu/masters\\_theses/5727](http://scholarsmine.mst.edu/masters_theses/5727)

- Sorensen, K.K. and Okkels, N. 2013, September. Correlation between drained shear strength and plasticity index of undisturbed overconsolidated clays. In *Proceedings of the 18th International Conference on Soil Mechanics and Geotechnical Engineering, Paris* (pp. 1-6).
- Spoor, G. 1969. Design of soil engaging implements. *Farm Machine Design Engineering*. 3, pp.22-26.
- Srinivasan, J.T. (2010). Understanding the kole lands in Kerala as a multiple use wetland ecosystem. RULNR Working Paper no. 5, Centre for Economic and Social Studies, Hyderabad
- Summers, J.D., Khalilian, A. and Batchelder, D.G. 1986. Draft relationships for primary tillage in Oklahoma soils. *Trans. ASAE* 29(1): 37-39
- Tada, A. 1987. Bearing capacity. In: Tabuchi, T., Iwata, S., Hasegawa, S., Woodhead, T. and Maurer, E. (eds.), *Physical Measurements in Flooded Soils - The Japanese Methodologies*. IRRI, Los Banos, Philippines, pp. 55-61.
- Tayel M.Y., Shaaban, S.M., and Mansour, H.A. 2015. Effect of Plowing Conditions on the Tractor Wheel Slippage and Fuel Consumption in Sandy Soil. *Int. J. Chem. Tech. Research* ISSN: 0974-4290. 8(12): 151-159.
- Taylor, H.M. and Gardner, H.R. 1963. Penetration of cotton seedling tap roots as influenced by bulk density, moisture content and strength of soil. *Soil Sci.* 96(3): 153-156.
- Vigneshwari, C., Vimala and Sumithra, G. 2013. Sensor based assistance system for visually impaired. *Int. J. Eng. Trends Technol.* 4(10): 4338-4343.
- Walkley, A.J. and Black, I.A. 1934. Estimation of soil organic carbon by chromic acid titration method. *Soil Sci.* 31: 29-38.
- Wolf, D., Garner, T.H. and Davis, J.W. 1981. Tillage mechanical energy input and soil-crop response. *Trans. ASAE*, 24(6): 1412-1419.

- Zadeh, S.R.A., 2006. *Modelling of energy requirements by a narrow tillage tool* (Doctoral dissertation, University of Saskatchewan), pp. 172.  
Available: <https://core.ac.uk/download/pdf/55299479.pdf>
- Zhang, Z.X. and Kushwaha, R.L. 1999. Applications of neural networks to simulate soil-tool interaction and soil behavior. *Can. Agric. Eng.* 41(2):119-125
- Zoerb, G.C. and Popoff, J. 1967. Direct indication of tractor-wheel slip. *Canadian Agric. Eng.* 9(2): 91-93.
- Zoz, F.M., and Grisso, R.D. 2003. *Traction and tractor performance*. St. Joseph, Mich. ASAE, 46p.



# *Appendices*

## Appendix – I

### Preliminary soil studies

*Testing of soil samples in connection with PhD programme of Smt. Suma Nair, Asst. Professor, Dept of FPME, KCAET, Tavanur, Malappuram.*

#### ANALYSIS OF SOIL SAMPLES

<b>Sample data</b>	Laboratory No.	24433	24434
	Report No.	SM-4/2016	SM-4/2016
	Date of receipt of sample	24/11/15	24/11/15
	Pit No.	BH I	BH II
	Depth of sampling in m	G.L.	G.L.
	Nature of sample	Undisturbed	Undisturbed
	Texture	Clay	Clay
	Colour	Light buff	Light buff
<b>Physical characteristics</b>	Specific gravity	2.40	2.26
	Natural moisture content %	53	53
	Bulk density g/cc	1.6	1.74
	Void ratio	1.66	1.42
	Porosity %	62	59
	Liquid Limit	66	59
	Plastic Limit	59	40
	Plasticity Index	17	19
	Shrinkage Limit	9.89	11.25
	Class	MH/OH	MH/OH
	Clay %	45	58
	Silt %	46	39
	Sand %	6	3
	Gravel %	3	0
	Uniformity coefficient	--	--
<b>Tri-axial Shear</b>	Angle of internal friction in degrees	22	17
	Cohesion in kg/cm <sup>2</sup>	0.069	0.042
<b>Chemical analysis</b>	Organic content, percent by weight	2.634	2.645
	Sulphate content	--	--
	Soluble salt content in %	--	--
	pH value	--	--
<b>Other tests if any</b>	Swelling Index	--	--

ASSISTANT DIRECTOR

DEPUTY DIRECTOR

Appendix – II

**Soil properties of research locations**

I. Variation in cone index values at the three research locations

A. Variation in cone index over depth in the field soils of Pullazhi *kolepadavu*, Thrissur

Depth (cm)	Cone index (kg cm <sup>-2</sup> )					
	PU1	PU2	PU3	PU4	PU5	Mean
7.5	1.25	1.41	1.48	1.56	1.56	1.45
10	1.41	1.48	1.72	2.18	2.10	1.78
12.5	1.72	2.03	1.64	2.10	2.57	2.01
15	2.41	2.26	2.18	5.13	3.81	3.16
17.5	3.27	2.65	3.42	5.59	5.05	4.00
20	4.82	3.50	5.59	6.37	5.05	5.07
22.5	5.21	3.66	6.06	6.14	4.28	5.07
25	6.37	4.82	6.52	6.52	3.81	5.61
27.5	5.44	4.97	6.76	6.83	3.50	5.50
30	6.06	5.90	6.68	7.69	3.19	5.90

B. Variation in cone index over depth in the field soils of Kolothumpadam *kolepadavu*, Ponnani

Depth (cm)	Cone index (kg cm <sup>-2</sup> )					
	PO1	PO2	PO3	PO4	PO5	Mean
7.50	0.17	0.17	0.17	0.24	0.24	0.20
10.00	0.24	0.24	0.24	0.24	0.40	0.28
12.50	0.24	0.24	0.24	0.32	0.48	0.31
15.00	0.32	0.40	0.32	0.48	0.55	0.41
17.50	0.40	0.63	0.48	0.55	0.71	0.55
20.00	1.10	0.86	0.86	1.02	1.17	1.00
22.50	0.79	1.02	0.94	1.10	1.25	1.02
25.00	1.87	1.95	1.56	2.18	1.72	1.86
27.50	4.43	4.35	4.12	3.89	4.20	4.20
30.00	7.30	6.52	6.21	6.37	5.90	6.46

C. Variation in cone index over depth in the field soils of Tavanur (non – kole)

Depth (cm)	Cone index (kg cm <sup>-2</sup> )					
	TVR1	TVR2	TVR3	TVR4	TVR5	Mean
7.50	0.40	0.40	0.40	0.40	0.40	1.58
10.00	0.48	0.40	0.40	0.40	0.63	2.05
12.50	0.79	0.55	0.55	0.55	0.79	2.62
15.00	1.10	0.63	0.63	0.86	1.10	3.22
17.50	1.64	1.02	1.02	1.17	1.79	4.02
20.00	2.26	1.41	3.03	2.26	3.58	5.42
22.50	2.96	2.88	5.75	3.27	6.45	7.30
25.00	3.89	5.44	6.91	5.28	7.45	9.00
27.50	4.51	8.77	7.45	8.00	7.84	10.68
30.00	6.60	7.69	7.84	8.46	8.00	11.43

## II. Shear strength measured in the fields at research locations

Depth (m)	Sample	Shear strength (kPa)		
		Pullazhi	Ponnani	Tavanur
0.2	I	23.44	15.63	26.05
	II	26.05	15.63	26.05
	III	20.84	18.23	28.65
	Mean	23.44	16.5	26.92
0.4	I	52.10	72.94	49.49
	II	57.31	72.94	49.49
	III	54.70	78.15	46.89
	Mean	54.70	74.67	48.62
0.6	I	15.63	83.36	49.49
	II	13.02	88.57	59.91
	III	13.02	93.78	54.70
	Mean	13.89	88.57	54.70

## III. Organic carbon and organic matter content of soils at research locations

Sl. No.	Sample	Organic carbon (%)	Organic matter (%)	Remarks
1	PU1	3.68	6.33	High
2	PU2	3.15	5.42	High
3	PU3	3.50	6.02	High
4	PO1	3.46	5.95	High
5	PO2	3.54	6.09	High
6	PO3	3.65	6.28	High
7	TVR1	1.40	2.41	Medium
8	TVR2	1.29	2.22	Medium
9	TVR3	0.78	1.34	Medium

IV Particle size distribution of the soils at the three research locations

Location	Replication	Particle fractions (%)			Total (%)
		Sand	Silt	Clay	
PO1	R1	2.3335	43.95	53.7165	100
	R2	3.0021	41.1197	55.8782	100
	R3	2.9618	39.9572	57.081	100
	Mean	2.7658	41.67563	55.55857	100
PO2	R1	3.9705	43.125	52.9045	100
	R2	4.3729	40.468	55.1591	100
	R3	3.8156	43.054	53.1304	100
	Mean	4.053	42.21567	53.73133	100
PO3	R1	4.3772	43.2435	52.3793	100
	R2	3.0618	44.9854	51.9528	100
	R3	2.5738	46.4227	51.0035	100
	Mean	3.3376	44.88387	51.77853	100
PU1	R1	4.083	46.3125	49.6045	100
	R2	6.2012	48.7853	45.0135	100
	R3	6.9147	49.0054	44.0799	100
	Mean	5.732967	48.0344	46.23263	100
PU2	R1	7.041	43.734	49.225	100
	R2	6.8973	47.7901	45.3126	100
	R3	6.3782	45.0549	48.5669	100
	Mean	6.772167	45.52633	47.7015	100
PU3	R1	7.674	44.8962	47.4298	100
	R2	6.672	45.7103	47.6177	100
	R3	5.822	45.9448	48.2332	100
	Mean	6.722667	45.5171	47.76023	100
TVR1	R1	59.6195	26.025	14.3555	100
	R2	60.1045	25.9943	13.9012	100
	R3	62.5845	24.2977	13.1178	100
	Mean	60.7695	25.439	13.7915	100
TVR2	R1	66.682	22.575	10.743	100
	R2	56.5682	27.2755	16.1563	100
	R3	63.9845	23.0236	12.9919	100
	Mean	62.41157	24.29137	13.29707	100
TVR3	R1	67.682	22.0816	10.2364	100
	R2	59.9967	28.7046	11.2987	100
	R3	64.2782	22.7251	12.9967	100
	Mean	63.98563	24.50377	11.5106	100

PO – Kolothumpadam *kolepadavu*, Ponnani *kole*, PU – Pullazhi *kolepadavu*, Thrissur *kole*, TVR – Athalur, Tavanur (non – *kole*)

### Appendix – III

#### Components of profile measuring instrument

##### A. Specifications of the DC motor used in profile measuring instrument

SPECIFICATION	VALUE
Type	DC
Shaft diameter	6 mm with M3 threaded hole
Rotation	300 rpm
Base RPM	18000 rpm
Input voltage	12 V
Weight	250 g
Torque	30 Kg cm
No load current	800 Ma
Load current	Up to 7.5 A(Max)

##### B. Specifications of the Arduino Uno board

SPECIFICATION	VALUE
Microcontroller	ATmega328P
Operating Voltage	5 V
Input Voltage (recommended)	7-12 V
Input Voltage (limit)	6-20 V
Digital I/O Pins	14 (of which 6 provide PWM output)
PWM Digital I/O Pins	6
Analogue Input Pins	6
DC Current per I/O Pin	20 mA
DC Current for 3.3V Pin	50 mA
Flash Memory	32 KB (ATmega328P) of which 0.5 KB used by boot loader
SRAM	2 KB (ATmega328P)
EEPROM	1 KB (ATmega328P)
Clock Speed	16 MHz
Length	68.6 mm
Width	53.4 mm
Weight	25 g

## Appendix – IV

### Program code for profile measuring device

```
//This is the programme for the working of 2D Profilemeter
```

```
#include <SD.h>
```

```
//declaring all the pins
```

```
    const int xTrigPin = 2;
```

```
    const int xEchoPin = 3;
```

```
    const int yTrigPin = 4;
```

```
    const int yEchoPin = 5;
```

```
    const int ledPinRed = 9;
```

```
    const int sdOutPin = 10;
```

```
    const int xMotorPinF = 15;
```

```
    const int xMotorPinR = 14;
```

```
//declaring all the constants
```

```
    const int noSamples = 30;
```

```
    const int minX = 200;
```

```
    const int maxX = 800;
```

```
    int n = 0;
```

```
    int xDist;
```

```
    boolean xMotorForward = HIGH;
```

```
    boolean xChangeDir = LOW;
```

```
void setup()
```

```
{
```

```
    Serial.begin(9600);
```

```
    Serial.println("setup started");
```

```
//declaring all the pinmode
```

```
    pinMode(xTrigPin , OUTPUT);
```

```
    pinMode(xEchoPin , INPUT);
```

```
    pinMode(yTrigPin , OUTPUT);
```

```
    pinMode(yEchoPin , INPUT);
```

```
    pinMode(ledPinRed , OUTPUT);
```

```
    pinMode(sdOutPin , OUTPUT);
```

```
    pinMode(xMotorPinF , OUTPUT);
```



```

        pinMode(xMotorPinR , OUTPUT);
Serial.println(MeasureDist(1));
//Checking the SD Card status
while(!SD.begin(sdOutPin))
{
    digitalWrite(ledPinRed, HIGH);
    Serial.println("sdcard not ready");
    delay(500);
}
while(MeasureDist(1)>minX)
{
    motorRun(xMotorPinF,xMotorPinR,HIGH,10000);
}
delay(1000);
Serial.println(MeasureDist(1));
Serial.println("START OF READING");
writeData("data.txt","START OF READING",HIGH);
writeData("Profile.scr","LINE",HIGH);
}
void loop()
{
    Serial.println("I AM IN LOOP");
    while(MeasureDist(1) < maxX)
    {
        delay(5000);
        Serial.print(MeasureDist(1));
        Serial.print(",");
        Serial.println(MeasureDist(2));
        writeData("data.txt",String(MeasureDist(1)),LOW);
        writeData("data.txt",String(MeasureDist(2)),HIGH);
        writeData("Profile.scr",String(MeasureDist(1)),LOW);
        writeData("Profile.scr",String(1000-MeasureDist(2)),HIGH);
        motorRun(xMotorPinF,xMotorPinR,LOW,2000);
    }
}

```

```

if(MeasureDist(1) > maxX)
{
  if(n==0)
  {
    n=n+1;
    Serial.println("END OF READING");
    writeData("data.txt","END OF READING",HIGH);
    writeData("Profile.scr"," ",HIGH);
//loop completed
  }
  digitalWrite(ledPinRed, HIGH);
  delay(1000);
  digitalWrite(ledPinRed, LOW);
}
}

//This is the subprogram for motor run.
void motorRun(int motorPin1,int motorPin2,boolean motorDir,int delayTime)
{
  digitalWrite(motorPin1,motorDir);
  digitalWrite(motorPin2,!motorDir);
  delay(delayTime);
  digitalWrite(motorPin1,LOW);
  digitalWrite(motorPin2,LOW);
}

//This is the subprogram for reading distance.
int getDistance(int TrigPin,int EchoPin)
{
  int i;
  int dist[noSamples];
  float duration;
  float distance;
  for (i = 0;i<= (noSamples-1); i++)
  {
    digitalWrite(TrigPin, LOW);

```

```

delayMicroseconds(1000);
digitalWrite(TrigPin, HIGH);
delayMicroseconds(1000);
digitalWrite(TrigPin, LOW);
duration= pulseIn(EchoPin, HIGH);
distance = duration /28 /2 ;
dist[i] = getInteger(distance);
}
delay(1000);
return getMode(dist);
Serial.println("distance");
}
// This is the subprogramme for rounding the decimal values to nearest integer
int getInteger(float myNum)
{
int myRem;
myRem = (int)(myNum *100) % 10);
if (myRem >= 5)
{
return int(myNum*10) + 1;
}
else
{
return int (myNum*10);
}
}
//This is the subprogram for calculating mode
int getMode(int numbers[])
{
int i;
int j;
int maxNumb;
int maxCount;
int maxRepeat = 0;

```

```

int count[noSamples];
for (i=0; i<(noSamples); i++)
{
    count[i] = 0;
    for (j=0; j<(noSamples); j++)
    {
        if (numbers[i] == numbers[j])
        {
            count [i] = count[i]++;
        }
    }
}
maxNumb = numbers[0];
maxCount = count[0];
for (i=1; i<(noSamples); i++)
{
    if (count[i] > maxCount)
    {
        maxNumb = numbers[i];
        maxCount = count [i];
    }
}
for (i=0; i<(noSamples); i++)
{
    if (maxCount == count[i])
    {
        maxRepeat++;
    }
}
if (maxCount == maxRepeat)
{
    return maxNumb;
}
else

```

```

{
    return 0;
}
}
//This is the subprogram for writing the readings
int MeasureDist (int drn)
{
    int TrigPin;
    int EchoPin;
    int MeasuredDist = 0;
    switch (drn)
    {
        case 1:
            TrigPin = xTrigPin;
            EchoPin = xEchoPin;
            break;
        case 2:
            TrigPin = yTrigPin;
            EchoPin = yEchoPin;
            break;
    }
    while (MeasuredDist == 0)
    {
        MeasuredDist = getDistance(TrigPin, EchoPin);
    }
    return MeasuredDist;
}
void writeData (char *fileName, String Data, boolean nextLine)
{
    File dataFile;
    dataFile = SD.open(fileName, FILE_WRITE);
    if (nextLine)
    {
        dataFile.println (Data);
    }
}

```

```
}  
else  
{  
    dataFile.print (Data);  
    dataFile.print (",");  
}  
dataFile.close();  
}  
//End of the Programme
```

Appendix – V

**Changes in cone index (kg cm<sup>-2</sup>) at different depths across bund types at consecutive time intervals at research locations**

A. Changes at Pullazhi kolepadavu, Thrissur kole

Depth (cm)	Type of bund	Cone Index (kg cm <sup>-2</sup> )		
		Day 1	Day 3	Day 7
7.50	Manual	0.20 <sup>b</sup>	0.32 <sup>b</sup>	0.83 <sup>c</sup>
	BF3	0.43 <sup>a</sup>	0.71 <sup>a</sup>	1.47 <sup>a</sup>
	BF2	0.45 <sup>a</sup>	0.63 <sup>a</sup>	1.56 <sup>a</sup>
	BF1	0.46 <sup>a</sup>	0.66 <sup>a</sup>	1.16 <sup>b</sup>
10.00	Manual	0.26 <sup>b</sup>	0.43 <sup>b</sup>	1.16 <sup>b</sup>
	BF3	0.57 <sup>ab</sup>	0.76 <sup>a</sup>	1.53 <sup>ab</sup>
	BF2	0.76 <sup>a</sup>	0.90 <sup>a</sup>	1.93 <sup>a</sup>
	BF1	0.79 <sup>a</sup>	0.83 <sup>a</sup>	1.41 <sup>b</sup>
12.50	Manual	0.29 <sup>b</sup>	0.42 <sup>c</sup>	1.79 <sup>b</sup>
	BF3	1.25 <sup>a</sup>	2.07 <sup>a</sup>	2.71 <sup>a</sup>
	BF2	1.21 <sup>a</sup>	1.50 <sup>ab</sup>	2.11 <sup>b</sup>
	BF1	1.11 <sup>a</sup>	0.91 <sup>bc</sup>	1.76 <sup>b</sup>
15.00	Manual	0.34 <sup>c</sup>	0.48 <sup>c</sup>	2.57 <sup>bc</sup>
	BF3	2.48 <sup>a</sup>	3.21 <sup>a</sup>	4.28 <sup>a</sup>
	BF2	1.86 <sup>ab</sup>	1.7 <sup>b</sup>	3.36 <sup>ab</sup>
	BF1	1.42 <sup>b</sup>	1.11 <sup>bc</sup>	2.23 <sup>c</sup>
17.50	Manual	0.42 <sup>c</sup>	0.48 <sup>c</sup>	3.04 <sup>c</sup>
	BF3	4.18 <sup>a</sup>	4.83 <sup>a</sup>	6.28 <sup>a</sup>
	BF2	2.32 <sup>b</sup>	1.98 <sup>b</sup>	4.51 <sup>b</sup>
	BF1	1.87 <sup>b</sup>	1.70 <sup>b</sup>	2.01 <sup>d</sup>
20.00	Manual	0.46 <sup>c</sup>	0.54 <sup>c</sup>	3.70 <sup>b</sup>
	BF3	5.33 <sup>a</sup>	6.40 <sup>a</sup>	6.86 <sup>a</sup>
	BF2	2.90 <sup>b</sup>	2.20 <sup>b</sup>	5.78 <sup>a</sup>
	BF1	2.37 <sup>b</sup>	2.59 <sup>b</sup>	3.00 <sup>b</sup>
22.50	Manual	0.68 <sup>c</sup>	0.62 <sup>c</sup>	3.41 <sup>c</sup>
	BF3	6.68 <sup>a</sup>	6.86 <sup>a</sup>	7.16 <sup>a</sup>
	BF2	4.26 <sup>b</sup>	2.60 <sup>b</sup>	5.84 <sup>b</sup>
	BF1	2.91 <sup>b</sup>	3.02 <sup>b</sup>	3.21 <sup>c</sup>
25.00	Manual	0.90 <sup>b</sup>	1.39 <sup>c</sup>	3.28 <sup>b</sup>
	BF3	7.41 <sup>a</sup>	7.17 <sup>a</sup>	7.36 <sup>a</sup>
	BF2	5.56 <sup>a</sup>	2.82 <sup>b</sup>	6.14 <sup>a</sup>
	BF1	2.68 <sup>b</sup>	3.93 <sup>b</sup>	3.52 <sup>b</sup>
27.50	Manual	1.27 <sup>b</sup>	2.69 <sup>c</sup>	3.05 <sup>b</sup>
	BF3	7.58 <sup>a</sup>	7.41 <sup>a</sup>	7.52 <sup>a</sup>
	BF2	6.42 <sup>a</sup>	3.14 <sup>bc</sup>	6.09 <sup>a</sup>
	BF1	1.92 <sup>b</sup>	4.37 <sup>b</sup>	4.21 <sup>b</sup>

271

30.00	Manual	2.51 <sup>c</sup>	4.29 <sup>c</sup>	3.07 <sup>c</sup>
	BF3	7.59 <sup>a</sup>	7.47 <sup>a</sup>	7.52 <sup>a</sup>
	BF2	6.65 <sup>a</sup>	4.69 <sup>c</sup>	6.35 <sup>ab</sup>
	BF1	4.51 <sup>b</sup>	5.83 <sup>b</sup>	5.19 <sup>b</sup>

B. Changes at Kolothumpadam *kolepadavu*, Ponnani *kole*

Depth (cm)	Type of bund	Cone Index (kg cm <sup>-2</sup> )		
		Day 1	Day 3	Day 7
7.50	Manual	0.28 <sup>b</sup>	1.41 <sup>a</sup>	3.31 <sup>ab</sup>
	BF3	0.31 <sup>b</sup>	1.10 <sup>bc</sup>	3.31 <sup>ab</sup>
	BF2	0.23 <sup>b</sup>	0.94 <sup>c</sup>	2.17 <sup>b</sup>
	BF4	0.43 <sup>a</sup>	1.30 <sup>ab</sup>	3.58 <sup>a</sup>
10.00	Manual	0.55 <sup>a</sup>	1.64 <sup>a</sup>	3.45 <sup>ab</sup>
	BF3	0.42 <sup>ab</sup>	1.47 <sup>a</sup>	3.97 <sup>a</sup>
	BF2	0.29 <sup>b</sup>	1.36 <sup>a</sup>	2.45 <sup>b</sup>
	BF4	0.54 <sup>a</sup>	1.61 <sup>a</sup>	3.52 <sup>ab</sup>
12.50	Manual	0.66 <sup>a</sup>	1.47 <sup>a</sup>	2.54 <sup>a</sup>
	BF3	0.68 <sup>a</sup>	2.00 <sup>a</sup>	3.47 <sup>a</sup>
	BF2	0.34 <sup>b</sup>	1.90 <sup>a</sup>	2.74 <sup>a</sup>
	BF4	0.88 <sup>a</sup>	1.86 <sup>a</sup>	2.57 <sup>a</sup>
15.00	Manual	0.77 <sup>b</sup>	1.49 <sup>b</sup>	2.54 <sup>a</sup>
	BF3	1.08 <sup>ab</sup>	2.62 <sup>a</sup>	3.31 <sup>a</sup>
	BF2	0.71 <sup>b</sup>	2.23 <sup>ab</sup>	3.16 <sup>a</sup>
	BF4	1.24 <sup>a</sup>	1.93 <sup>ab</sup>	2.79 <sup>a</sup>
17.50	Manual	0.94 <sup>b</sup>	1.59 <sup>c</sup>	2.88 <sup>a</sup>
	BF3	1.38 <sup>a</sup>	3.31 <sup>a</sup>	3.56 <sup>a</sup>
	BF2	0.85 <sup>b</sup>	2.62 <sup>b</sup>	3.55 <sup>a</sup>
	BF4	1.70 <sup>a</sup>	2.32 <sup>b</sup>	3.42 <sup>a</sup>
20.00	Manual	1.14 <sup>b</sup>	2.00 <sup>b</sup>	3.49 <sup>a</sup>
	BF3	1.72 <sup>ab</sup>	3.79 <sup>a</sup>	4.20 <sup>a</sup>
	BF2	1.33 <sup>ab</sup>	2.82 <sup>b</sup>	3.98 <sup>a</sup>
	BF4	1.93 <sup>a</sup>	2.63 <sup>b</sup>	4.23 <sup>a</sup>
22.50	Manual	2.04 <sup>a</sup>	2.00 <sup>a</sup>	4.29 <sup>a</sup>
	BF3	2.09 <sup>a</sup>	3.98 <sup>a</sup>	4.54 <sup>a</sup>
	BF2	1.90 <sup>a</sup>	3.10 <sup>a</sup>	4.37 <sup>a</sup>
	BF4	2.41 <sup>a</sup>	3.14 <sup>a</sup>	4.76 <sup>a</sup>
25.00	Manual	2.80 <sup>a</sup>	2.29 <sup>b</sup>	3.83 <sup>b</sup>
	BF3	2.76 <sup>a</sup>	4.48 <sup>a</sup>	5.39 <sup>a</sup>
	BF2	3.17 <sup>a</sup>	3.69 <sup>a</sup>	5.14 <sup>a</sup>
	BF4	3.08 <sup>a</sup>	3.56 <sup>a</sup>	5.13 <sup>a</sup>

292



27.50	Manual	3.11 <sup>a</sup>	2.90 <sup>b</sup>	5.11 <sup>a</sup>
	BF3	3.42 <sup>a</sup>	4.93 <sup>a</sup>	5.56 <sup>a</sup>
	BF2	3.38 <sup>a</sup>	4.04 <sup>ab</sup>	5.48 <sup>a</sup>
	BF4	3.69 <sup>a</sup>	3.83 <sup>ab</sup>	5.72 <sup>a</sup>
30.00	Manual	3.83 <sup>b</sup>	3.69 <sup>b</sup>	5.69 <sup>a</sup>
	BF3	4.12 <sup>ab</sup>	5.53 <sup>a</sup>	6.37 <sup>a</sup>
	BF2	4.49 <sup>a</sup>	4.69 <sup>a</sup>	5.55 <sup>a</sup>
	BF4	4.11 <sup>ab</sup>	4.82 <sup>a</sup>	6.35 <sup>a</sup>

C. Changes at Tavanur with NH 3230 as power source

Depth (cm)	Type of bund	Cone Index (kg cm <sup>-2</sup> )		
		Day 1	Day 3	Day 7
7.50	Manual	0.45 <sup>a</sup>	0.93 <sup>a</sup>	1.55 <sup>a</sup>
	BF3	0.40 <sup>a</sup>	0.48 <sup>b</sup>	1.52 <sup>a</sup>
	BF2	0.26 <sup>bc</sup>	0.49 <sup>b</sup>	1.04 <sup>b</sup>
	BF1	0.24 <sup>c</sup>	0.42 <sup>b</sup>	0.88 <sup>b</sup>
	BF4	0.35 <sup>ab</sup>	0.54 <sup>b</sup>	1.08 <sup>b</sup>
10.00	Manual	0.55 <sup>a</sup>	1.19 <sup>a</sup>	2.00 <sup>a</sup>
	BF3	0.42 <sup>ab</sup>	0.62 <sup>b</sup>	1.58 <sup>b</sup>
	BF2	0.28 <sup>b</sup>	0.52 <sup>b</sup>	1.04 <sup>c</sup>
	BF1	0.24 <sup>b</sup>	0.46 <sup>b</sup>	0.99 <sup>c</sup>
	BF4	0.32 <sup>b</sup>	0.63 <sup>b</sup>	1.10 <sup>c</sup>
12.50	Manual	1.04 <sup>a</sup>	1.62 <sup>a</sup>	2.65 <sup>a</sup>
	BF3	0.54 <sup>b</sup>	0.79 <sup>b</sup>	1.42 <sup>b</sup>
	BF2	0.34 <sup>b</sup>	0.57 <sup>b</sup>	1.13 <sup>b</sup>
	BF1	0.32 <sup>b</sup>	0.59 <sup>b</sup>	1.11 <sup>b</sup>
	BF4	0.39 <sup>b</sup>	0.62 <sup>b</sup>	1.16 <sup>b</sup>
15.00	Manual	1.38 <sup>a</sup>	2.69 <sup>a</sup>	3.86 <sup>a</sup>
	BF3	0.69 <sup>b</sup>	0.86 <sup>b</sup>	1.53 <sup>b</sup>
	BF2	0.46 <sup>c</sup>	0.91 <sup>b</sup>	1.42 <sup>b</sup>
	BF1	0.46 <sup>c</sup>	0.82 <sup>b</sup>	1.33 <sup>b</sup>
	BF4	0.45 <sup>c</sup>	0.79 <sup>b</sup>	1.25 <sup>b</sup>
17.50	Manual	2.29 <sup>a</sup>	3.76 <sup>a</sup>	4.73 <sup>a</sup>
	BF3	0.83 <sup>b</sup>	1.19 <sup>c</sup>	1.58 <sup>cd</sup>
	BF2	1.38 <sup>b</sup>	2.26 <sup>b</sup>	2.80 <sup>b</sup>
	BF1	1.16 <sup>b</sup>	1.80 <sup>b</sup>	2.59 <sup>bc</sup>
	BF4	0.85 <sup>b</sup>	0.82 <sup>c</sup>	1.36 <sup>d</sup>
20.00	Manual	3.31 <sup>a</sup>	6.18 <sup>a</sup>	6.32 <sup>a</sup>
	BF3	1.27 <sup>c</sup>	1.53 <sup>d</sup>	2.07 <sup>c</sup>
	BF2	3.25 <sup>a</sup>	4.17 <sup>b</sup>	4.68 <sup>b</sup>
	BF1	2.54 <sup>b</sup>	3.00 <sup>c</sup>	3.92 <sup>b</sup>
	BF4	1.17 <sup>c</sup>	1.33 <sup>d</sup>	1.79 <sup>c</sup>

22.50	Manual	4.69 <sup>a</sup>	7.05 <sup>a</sup>	7.53 <sup>a</sup>
	BF3	2.35 <sup>c</sup>	3.16 <sup>c</sup>	4.01 <sup>cd</sup>
	BF2	4.34 <sup>a</sup>	5.14 <sup>b</sup>	5.69 <sup>b</sup>
	BF1	3.39 <sup>b</sup>	4.24 <sup>b</sup>	4.21 <sup>c</sup>
	BF4	2.17 <sup>c</sup>	2.49 <sup>c</sup>	3.04 <sup>d</sup>
25.00	Manual	5.10 <sup>ab</sup>	7.66 <sup>a</sup>	7.31 <sup>a</sup>
	BF3	3.80 <sup>c</sup>	4.66 <sup>d</sup>	5.05 <sup>b</sup>
	BF2	5.50 <sup>a</sup>	6.14 <sup>b</sup>	6.65 <sup>a</sup>
	BF1	4.37 <sup>bc</sup>	4.91 <sup>cd</sup>	5.02 <sup>b</sup>
	BF4	5.28 <sup>a</sup>	5.84 <sup>bc</sup>	6.31 <sup>ab</sup>
27.50	Manual	5.55 <sup>b</sup>	7.41 <sup>a</sup>	8.01 <sup>a</sup>
	BF3	5.07 <sup>b</sup>	6.17 <sup>ab</sup>	6.55 <sup>bc</sup>
	BF2	6.63 <sup>a</sup>	6.65 <sup>ab</sup>	7.07 <sup>ab</sup>
	BF1	5.41 <sup>b</sup>	5.52 <sup>b</sup>	5.44 <sup>c</sup>
	BF4	7.25 <sup>a</sup>	7.11 <sup>a</sup>	7.66 <sup>ab</sup>
30.00	Manual	5.97 <sup>b</sup>	7.55 <sup>a</sup>	7.55 <sup>ab</sup>
	BF3	6.62 <sup>b</sup>	6.74 <sup>a</sup>	7.13 <sup>b</sup>
	BF2	7.38 <sup>a</sup>	7.30 <sup>a</sup>	7.64 <sup>ab</sup>
	BF1	6.01 <sup>b</sup>	6.23 <sup>a</sup>	6.09 <sup>c</sup>
	BF4	7.52 <sup>a</sup>	7.75 <sup>a</sup>	8.15 <sup>a</sup>

#### D. Changes at Tavanur with KTT as power source

Depth (cm)	Type of bund	Cone Index (kg cm <sup>-2</sup> )		
		Day 1	Day 3	Day 7
7.50	Manual	0.45 <sup>a</sup>	0.93 <sup>a</sup>	1.55 <sup>a</sup>
	BF2	0.35 <sup>a</sup>	0.35 <sup>b</sup>	0.49 <sup>b</sup>
	BF1	0.31 <sup>a</sup>	0.35 <sup>b</sup>	0.59 <sup>b</sup>
10.00	Manual	0.55 <sup>a</sup>	1.19 <sup>a</sup>	2.00 <sup>a</sup>
	BF2	0.43 <sup>a</sup>	0.43 <sup>b</sup>	0.54 <sup>b</sup>
	BF1	0.46 <sup>a</sup>	0.37 <sup>b</sup>	0.77 <sup>b</sup>
12.50	Manual	1.04 <sup>a</sup>	1.62 <sup>a</sup>	2.65 <sup>a</sup>
	BF2	0.48 <sup>b</sup>	0.51 <sup>b</sup>	0.68 <sup>b</sup>
	BF1	0.54 <sup>b</sup>	0.48 <sup>b</sup>	0.97 <sup>b</sup>
15.00	Manual	1.38 <sup>a</sup>	2.69 <sup>a</sup>	3.86 <sup>a</sup>
	BF2	0.57 <sup>b</sup>	0.68 <sup>b</sup>	0.79 <sup>b</sup>
	BF1	0.66 <sup>b</sup>	0.54 <sup>b</sup>	1.19 <sup>b</sup>
17.50	Manual	2.29 <sup>a</sup>	3.76 <sup>a</sup>	4.73 <sup>a</sup>
	BF2	0.71 <sup>b</sup>	1.73 <sup>b</sup>	1.02 <sup>b</sup>
	BF1	0.82 <sup>b</sup>	0.77 <sup>c</sup>	1.39 <sup>b</sup>
20.00	Manual	3.31 <sup>a</sup>	6.18 <sup>a</sup>	6.32 <sup>a</sup>
	BF2	1.49 <sup>b</sup>	2.68 <sup>b</sup>	1.80 <sup>b</sup>
	BF1	1.31 <sup>b</sup>	1.52 <sup>b</sup>	2.80 <sup>b</sup>

22.50	Manual	4.69 <sup>a</sup>	7.05 <sup>a</sup>	7.53 <sup>a</sup>
	BF2	1.84 <sup>b</sup>	3.25 <sup>b</sup>	2.63 <sup>c</sup>
	BF1	2.01 <sup>b</sup>	3.36 <sup>b</sup>	4.32 <sup>b</sup>
25.00	Manual	5.10 <sup>a</sup>	7.66 <sup>a</sup>	7.31 <sup>a</sup>
	BF2	2.69 <sup>b</sup>	5.81 <sup>b</sup>	4.97 <sup>b</sup>
	BF1	3.73 <sup>ab</sup>	6.20 <sup>b</sup>	5.69 <sup>b</sup>
27.50	Manual	5.55 <sup>a</sup>	7.41 <sup>a</sup>	8.01 <sup>a</sup>
	BF2	5.28 <sup>a</sup>	7.80 <sup>a</sup>	6.86 <sup>a</sup>
	BF1	5.45 <sup>a</sup>	7.10 <sup>a</sup>	6.73 <sup>a</sup>
30.00	Manual	5.97 <sup>b</sup>	7.55 <sup>a</sup>	7.55 <sup>ab</sup>
	BF2	7.08 <sup>a</sup>	8.49 <sup>a</sup>	7.83 <sup>a</sup>
	BF1	6.40 <sup>ab</sup>	7.64 <sup>a</sup>	7.42 <sup>a</sup>

285

Appendix - VI

**Speed of operation of different bund formers at research locations**

A. Speed of operation of different bund formers at Pullazhi *kole*

Trial	Speed (km h <sup>-1</sup> )		
	BF3	BF2	BF1
PU1	2.56	2.64	2.91
PU2	2.53	2.89	2.74
PU3	2.45	2.68	2.91
Average	2.51	2.74	2.85

B. Speed of operation of different bund formers at Ponnani *kole*

Trial	Speed (km h <sup>-1</sup> )		
	BF3	BF2	BF4
PO1	2.79	2.98	2.73
PO2	2.44	3.00	2.66
PO3	2.28	2.97	2.62
Average	2.50	2.98	2.67

C. Speed of operation of different bund formers using NH3230 tractor at Tavanur

Trial	Speed (km h <sup>-1</sup> )			
	BF3	BF2	BF1	BF4
TVR1	1.83	2.00	2.01	1.81
TVR2	1.96	2.03	2.06	1.88
TVR3	1.88	2.08	2.03	1.76
Average	1.89	2.04	2.03	1.82

D. Speed of operation of different bund formers using KAMCO TeraTrac tractor at Tavanur

Trial	Speed (km h <sup>-1</sup> )	
	BF2	BF1
TVR1	1.15	1.27
TVR2	1.31	1.50
TVR3	1.26	1.07
Average	1.24	1.28

**Draft measured during operation of different bund formers at three research locations**

A. Draft measured during operation of different bund formers at Pullazhi kole

Trial	Draft (N)											
	Big bund former			Medium bund former			Small bund former					
	Max	Min	Avg	Max	Min	Avg	Max	Min	Avg	Max	Min	Avg
PU1	5579.98	4648.35	5080.83	5325.01	3991.31	4694.44	4893.52	4363.96	4615.01			
PU2	5668.24	4775.84	5126.92	4824.87	4471.83	4677.77	4815.07	4462.03	4602.26			
PU3	5452.50	4511.06	5076.90	4952.36	4285.51	4641.49	4883.71	4059.95	4605.20			

B. Draft measured during operation of different bund formers at Ponnani kole

Trial	Draft (N)											
	Big bund former			Medium bund former			Combination					
	Max	Min	Avg	Max	Min	Avg	Max	Min	Avg	Max	Min	Avg
PO1	9532.06	8933.86	9246.69	8973.08	8551.40	8790.68	9483.03	8737.73	9089.78			
PO2	9541.87	9012.31	9298.67	8982.89	8414.11	8695.56	9541.87	9012.31	9281.99			
PO3	9571.29	8982.89	9231.00	8982.89	8492.56	8698.50	9571.29	8825.99	9206.48			

C. Draft measured during operation of different bund formers using NH3230 tractor at Tavanur

Trial	Draft (N)											
	Big bund former			Medium bund former			Small bund former			Combination		
	Max	Min	Avg	Max	Min	Avg	Max	Min	Avg	Max	Min	Avg
TVR1	9345.74	8257.20	8793.62	7325.57	5962.44	6870.54	7325.57	6109.54	6834.25	9139.80	8198.36	8716.15
TVR2	9453.61	8286.62	8831.87	7374.60	5972.25	6904.86	7394.21	6109.54	6804.83	9267.28	8374.88	8714.19
TVR3	8806.37	8276.81	8526.88	7227.50	6442.97	6938.20	7364.79	6227.22	6875.44	8806.37	8070.87	8458.24

D. Draft measured during operation of different bund formers using KAMCO TeraTrac tractor at Tavanur

Trial	Draft (N)					
	Medium bund former			Small bund former		
	Max	Min	Avg	Max	Min	Avg
TVR1	4442.41	3334.26	3949.14	3971.69	3275.42	3641.21
TVR2	4167.83	3608.85	3850.09	3863.82	3236.19	3585.31
TVR3	4020.73	3667.69	3857.94	3912.85	3344.07	3551.97

228

Appendix - VIII

**Fuel consumption of the implement observed at the research locations**

A. Fuel consumption measured at Pullazhi *kole*

Trial	Fuel consumption (L h <sup>-1</sup> )		
	BF3	BF2	BF1
PU1	3.48	2.75	3.43
PU2	3.73	3.57	2.77
PU3	3.93	3.48	3.46
Average	3.71	3.27	3.22

B. Fuel consumption measured at Ponnani *kole*

Trial	Fuel consumption (L h <sup>-1</sup> )		
	BF3	BF2	BF4
PO1	3.58	3.21	7.60
PO2	3.64	3.13	7.81
PO3	4.06	3.30	7.71
Average	3.76	3.21	7.71

C. Fuel consumption measured using NH3230 tractor at Tavanur

Trial	Fuel consumption (L h <sup>-1</sup> )			
	BF3	BF2	BF1	BF4
TVR1	3.00	2.40	2.51	6.44
TVR2	2.53	2.88	2.37	5.24
TVR3	3.00	2.77	2.70	5.27
Average	2.84	2.68	2.53	5.65

D. Fuel consumption measured using KAMCO TeraTrac tractor at Tavanur

Trial	Fuel consumption (L h <sup>-1</sup> )	
	BF2	BF1
TVR1	3.27	3.03
TVR2	3.60	3.33
TVR3	3.05	3.27
Average	3.31	3.21

Appendix - IX

**Capacity of the implement observed at the test locations**

A. Capacity of the implement at Pullazhi *kole*

Trial	Capacity (m h <sup>-1</sup> )		
	BF3	BF2	BF1
PU1	2557.24	2636.94	2914.29
PU2	2533.33	2885.11	2741.54
PU3	2454.55	2681.38	2908.80
Average	2515.04	2734.48	2854.88

B. Capacity of the implement at Ponnani *kole*

Trial	Capacity (m h <sup>-1</sup> )		
	BF3	BF2	BF4
PO1	2794.03	2983.96	1362.16
PO2	2436.36	2996.27	1330.05
PO3	2281.69	2972.48	1310.77
Average	2504.03	2984.24	1334.33

C. Capacity of the implement at Tavanur using NH3230 tractor

Trial	Capacity (m h <sup>-1</sup> )			
	BF3	BF2	BF1	BF4
TVR1	1833.33	2000.00	2009.30	905.03
TVR2	1960.71	2025.00	2057.14	937.50
TVR3	1876.60	2076.92	2025.00	878.05
Average	1890.21	2033.97	2030.48	906.86

D. Capacity of the implement at Tavanur using KAMCO TeraTrac tractor

Trial	Capacity (m h <sup>-1</sup> )	
	BF2	BF1
TVR1	1145.46	1274.34
TVR2	1309.09	1500.00
TVR3	1260.00	1067.80
Average	1238.18	1280.71

280



Appendix – X

**Wheel slip observed at the research locations**

A. Wheel slip measured at Pullazhi *kole*

Trial	Slip (%)		
	BF3	BF2	BF1
PU1	9.43	9.43	7.69
PU2	9.26	9.62	9.62
PU3	9.80	7.69	7.55
Average	9.50	8.91	8.29

B. Wheel slip measured at Ponnani *kole*

Trial	Slip (%)		
	BF3	BF2	BF4
PO1	12.50	12.50	11.25
PO2	12.50	10.00	12.32
PO3	14.63	12.20	12.50
Average	13.21	11.57	12.02

C. Wheel slip measured during operation of bund formers at Tavanur

Trial	Slip (%)			
	BF3	BF2	BF1	BF4
TVR1	7.50	7.32	5.00	6.16
TVR2	7.32	5.00	5.00	6.25
TVR3	7.50	5.00	5.00	6.25
Average	7.44	5.77	5.00	6.22

(Power source: NH 3230 tractor)

D. Wheel slip measured during operation of bund formers at Tavanur

Trial	Slip (%)	
	BF2	BF1
TVR1	7.41	5.77
TVR2	7.69	5.66
TVR3	9.43	7.55
Average	8.18	6.33

(Power source: KAMCO TeraTrac tractor)

## I. Cost of per hour operation of tractor

TRACTOR	KAMCO TeraTrac		John Deere 5042		New Holland 3230	
	Purchase price (Rs.)	300000	300000	900000	900000	850000
Salvage value (rs.)	30000	30000	90000	90000	85000	85000
Useful life of equipment (years)	10	10	10	10	10	10
Average annual use (h)	1000	1000	1000	1000	1000	1000
Interest rate (%)	10	10	10	10	10	10
Fuel consumption (l/h)						
Pullazhi	3.71					
Tavanur		3.31				
Ponnani			3.76			
Ponnani (combination run)				7.71		
Tavanur					2.84	
Tavanur (combination run)						5.65
Cost of fuel per litre (Rs.)	75	75	75	75	75	75
Cost of labour per day of 8 hours (Rs.)	1000	1000	1000	1000	1000	1000
<b>(i). FIXED COST PER YEAR (Rs.)</b>						
A. Depreciation (Rs.)	27000	27000	81000	81000	76500	76500
B. Interest (Rs.)	16500	16500	49500	49500	46750	46750
C. Insurance (Rs.)	3000	3000	9000	9000	8500	8500
D. Housing (Rs.)	3000	3000	9000	9000	8500	8500
E. Taxes (Rs.)	3000	3000	9000	9000	8500	8500
Total fixed cost per year (Rs.)	52500	52500	157500	157500	148750	148750
<b>Total fixed cost per hour (Rs.)</b>	<b>52.5</b>	<b>52.5</b>	<b>157.5</b>	<b>157.5</b>	<b>148.75</b>	<b>148.75</b>

<b>(ii). OPERATING COST</b>										
A.	Repair and maintenance cost (Rs.)	15000	15000	45000	45000	45000	42500	42500		
	Repair and maintenance cost per hour (Rs.)	15	15	45	45	45	42.5	42.5		
B.	Fuel cost (Rs./h)	278.25	248.25	282	578.25	213	213			
C.	Lubrication cost (Rs./h)	13.9125	12.4125	14.1	28.9125	10.65	10.65			
D.	Labour cost per hour (Rs.)	125	125	125	125	125	125			
	<b>Total operating cost per hour (Rs.)</b>	<b>432.1625</b>	<b>400.6625</b>	<b>466.1</b>	<b>777.1625</b>	<b>391.15</b>	<b>612.4375</b>			
	<b>TOTAL COST OF OPERATION (i+ii) OF TRACTOR PER HOUR (Rs.)</b>	<b>484.6625</b>	<b>453.1625</b>	<b>623.6</b>	<b>934.6625</b>	<b>539.9</b>	<b>761.1875</b>			

### II. Cost of fabrication of the bund strengthening implement

Type of implement	Weight (kg)	Material cost (Rs.)	Fabrication cost (Rs.)	Total cost (Rs.)	Cost of implement during operation (Rs.)
BF1	18.55	1113	3000	4113	12682
BF2	22.15	1329	3500	4829	13398
BF3	39.6	2376	5000	7376	15945
Frame	63.65	3819	4750	8569	

### III. Cost of per hour operation of bund strengthening implement

<b>EQUIPMENT</b>	<b>BF1</b>	<b>BF2</b>	<b>BF3</b>
Purchase price (Rs.)	12690	13400	15950
Salvage value (Rs.)	1269	1340	1595
Life of equipment (years)	10	10	10
Average annual use (h)	100	100	100
Interest rate (%)	10	10	10
<b>(i). FIXED COST PER YEAR (Rs.)</b>			
A. Depreciation (Rs.)	1142.1	1206	1435.5
B. Interest (Rs.)	697.95	737	877.25
C. Insurance (Rs.)	126.9	134	159.5
D. Housing (Rs.)	126.9	134	159.5
Total fixed cost per year (Rs.)	2093.85	2211	2631.75
<b>Total fixed cost per hour (Rs.)</b>	<b>20.9385</b>	<b>22.11</b>	<b>26.3175</b>
<b>(ii). OPERATIONAL COST</b>			
A. Repair and maintenance cost (Rs.)	634.5	670	797.5
Repair and maintenance cost per hour (Rs.)	6.345	6.7	7.975
<b>Total operating cost per hour (Rs.)</b>	<b>6.345</b>	<b>6.7</b>	<b>7.975</b>
<b>TOTAL COST (FIXED + VARIABLE) OF OPERATION OF IMPLEMENT PER HOUR (RS.)</b>	<b>27.2835</b>	<b>28.81</b>	<b>34.2925</b>

**IV. Cost of per hour operation of the tractor-implement combination at the different test locations (Rs.)**

Location	Pullazhi	Ponnani	Tavanur	
			NH3230	KTT
Power source	KTT	JD5042		
Type of implement				
BF1	511.95		567.18	480.45
BF2	513.47	652.41	568.71	481.97
BF3	518.96	657.89	574.19	
BF4		997.77	824.29	

**V. Cost of formation of one meter of bund (Rs.)**

Location	Pullazhi	Ponnani	Tavanur	
			NH3230	KTT
Power source	KTT	JD5042		
Type of implement				
BF1	0.18		0.28	0.38
BF2	0.19	0.22	0.28	0.39
BF3	0.21	0.26	0.30	
BF4		0.75	0.91	

KTT – KAMCO TeraTrac  
 JD5042 – John Deere 5042  
 NH3230 – New Holland 3230  
 BF1 – Small bund former  
 BF2 – Medium bund former  
 BF3 – Big bund former

**DEVELOPMENT OF A BUND STRENGTHENING IMPLEMENT FOR  
PADDY WETLANDS BASED ON SOIL - MACHINE PARAMETERS**

by

**SUMA NAIR  
(2014-28-102)**

**ABSTRACT OF THE THESIS**

**Submitted in partial fulfillment of the  
requirements for the degree of  
DOCTOR OF PHILOSOPHY**

**IN**

**AGRICULTURAL ENGINEERING  
(Farm Power Machinery)**

**Faculty of Agricultural Engineering & Technology  
Kerala Agricultural University**



**DEPARTMENT OF FARM MACHINERY AND POWER ENGINEERING  
KELAPPAJI COLLEGE OF AGRICULTURAL ENGINEERING AND TECHNOLOGY  
TAVANUR - 679573, MALAPPURAM  
KERALA, INDIA**

**2018**

## ABSTRACT

Three models (BF1, BF2 and BF3) of a low cost, tractor drawn bund strengthening implement were developed and their performance was evaluated at three test locations, viz., Pullazhi *kolepadavu* in Thrissur *kole* lands, Kolothumpadam *kolepadavu* in Ponnani *kole* lands and Athalur, Tavanur (non-*kole*). The forming board type design was chosen. The major dimensions of the developed models, viz., top width, bottom width and rear height are 150, 250 and 150 mm for BF1, 200, 350 and 150 mm for BF2 and 250, 400 and 250 mm respectively. The main parts of the implement were the MS angle bar tool frame and hitch assembly of size 1150 mm x 500 mm, implement frame made of MS angle bars to connect the forming board assembly to the tool frame, modified forming boards with gathering boards attached in the front, and a 400 mm long, three sided forming case at the rear which provided a plastered finish to the formed bund. All the elements, including the forming boards and the forming case, acted like a single unit.

Analyses of the various soil properties at the three test sites were also performed. The soils at Pullazhi *kolepadavu* and Kolothumpadam *kolepadavu* were silty clay while the soil at Tavanur was sandy loam in texture.

The dimensions of the bunds drawn by the implements were suited to the prevalent farmers' practice at Pullazhi and Ponnani. At Tavanur, new bunds could be drawn using the implements. At Pullazhi *kole* fields, models BF1 and BF2 showed a better performance in terms of strength measured as cone index. The performance of BF3 and BF4 gave the best results at Ponnani. BF2 or BF4, operated by NH 3230, were suitable to the Tavanur fields, in terms of strength of bund as assessed by cone index. Shear strength values exhibited by the manual bunds were always lesser than that by mechanically formed bunds at Pullazhi. Bunds formed by BF2 showed the highest value of 46.02 kPa at 0.2 m depth which went upto 40.81 kPa on the seventh day. The same trend was seen in Ponnani also but the bunds formed by BF3 and BF4 had the highest shear strength values.

The average speed of operation ranged from minimum of 1.24 km h<sup>-1</sup> when BF1 was operated by KTT at Tavanur, in sandy loam soils to 2.98 km h<sup>-1</sup> when BF2 was operated by JD 5042 at Ponnani. Draft was least for BF1 operated by KTT and highest for BF3 and BF4 operated in Ponnani silt-clay. The minimum fuel consumption was noted as 2.53 L h<sup>-1</sup> for BF1-NH 3230 combination at Tavanur while the maximum was 3.76 L h<sup>-1</sup> for BF3-JD 5042 at Ponnani. The BF4 trials had higher consumption of 7.71 L h<sup>-1</sup> in silty clay at Ponnani and 5.62 L h<sup>-1</sup> in sandy loam at Tavanur.

The maximum capacity of 2984.24 m h<sup>-1</sup> was observed for BF2 operated by JD 5042 at Ponnani *kole*. BF4 had lower capacities as two passes of the tractor were required to complete the operation. The minimum capacity of mechanical bund strengthening implement is 906.86 m h<sup>-1</sup>. The manual operation has a capacity of 62.5 m h<sup>-1</sup>. Thus there is a 14 times increase in capacity of bund formation by mechanical implements. Wheel slip is within the acceptable range of 5 to 15 per cent.

The cost of mechanical formation of bunds ranges from Rs. 18/- to Rs. 30/- per 100 m. while it ranges from Rs. 178/- to Rs. 227/- for manual operation. The developed implement had a FOS of 2.17.

Hence, taking all observations into account, it can be summarised that the bund strengthening implement model BF2 was found suitable to Pullazhi *kolepadavu* in terms of size, strength, lower moisture content and higher bulk density. At Ponnani, the models BF3 and BF4 performed well. However, as BF4 operation involved a higher fuel consumption and lower capacity of bund formation, the model BF3 can be recommended. At Tavanur fields, the prevalent manual bunds showed better performance parameters. However, new bunds can be formed in the fields using the developed implements. Trial BF4 and BF3 gave better performance in these soils.

174539

