

**DESIGN ANALYSIS OF KAU POKKALI PADDY HARVESTER  
TOWARDS THE DEVELOPMENT OF ITS SCALE DOWN PROTOTYPE**

by

**VENKATA REDDY H.K.**

**(2016 - 18 - 010)**

**THESIS**

**Submitted in partial fulfilment of the requirements for the degree of**

**MASTER OF TECHNOLOGY**

**IN**

**AGRICULTURAL ENGINEERING**

**(Farm Machinery and Power Engineering)**

**Faculty of Agricultural Engineering and Technology**

**Kerala Agricultural University**



**DEPARTMENT OF FARM MACHINERY AND POWER ENGINEERING**

**KELAPPAJI COLLEGE OF AGRICULTURAL ENGINEERING AND**

**TECHNOLOGY, TAVANUR - 679 573**

**KERALA, INDIA**

**2018**



**DECLARATION**

I, hereby declare that this thesis entitled “**DESIGN ANALYSIS OF KAU POKKALI PADDY HARVESTER TOWARDS THE DEVELOPMENT OF ITS SCALE DOWN PROTOTYPE**” is a bonafide record of research work done by me during the course of research and that the thesis has not previously formed the basis for the award to me of any degree, diploma, associate ship, fellowship or other similar title of any other University or Society.

Place: Tavanur

Date: 10/08/2018

Venkata reddy.H.K.  
**VENKATA REDDY H.K.**

(2016-18-010)

**CERTIFICATE**

Certified that this thesis entitled “**DESIGN ANALYSIS OF KAU POKKALI PADDY HARVESTER TOWARDS THE DEVELOPMENT OF ITS SCALE DOWN PROTOTYPE**” is a record of research work done independently by **Er. VENKATA REDDY H.K. (2016-18-010)** under my guidance and supervision and that it has not previously formed the basis for the award of any degree, diploma, fellowship or associate ship to him.

Place: Tavanur

Date: 10.8.18



**Dr. JAYAN P.R**

(Chairman, Advisory Committee)

Professor and Head

Dept. of FMPE

KCAET, Tavanur.

**CERTIFICATE**

We, the undersigned members of the advisory committee of **Mr. VENKATA REDDY H.K (2016-18-010)** a candidate for the degree of Master of Technology in Agricultural Engineering with major in Farm Power Machinery and Energy, agree that the thesis entitled **“DESIGN ANALYSIS OF KAU POKKALI PADDY HARVESTER TOWARDS THE DEVELOPMENT OF ITS SCALE DOWN PROTOTYPE”** may be submitted by **Mr. VENKATA REDDY H.K** in partial fulfillment of the requirement for the degree.

**Dr. JAYAN P.R**  
**(Chairman)**  
Professor and HOD  
Dept. of FMPE  
KCAET, Tavanur.

**Members:**

**Dr. Manoj Mathew**  
**(Member)**  
Professor (FPM)  
RRS, Mancompu

**Er. Shivaji K.P.**  
**(Member)**

Assistant Professor,  
Department of FMPE  
KCAET, Tavanur

**Dr. Suresh Kumar, P. K**  
**(Member)**  
Professor,  
Dept. of Agri.Engg.  
CoH, Vellanikkara

**Dr. Sasikala D**  
**(Member)**

Professor and Head,  
Dept. of IDE  
KCAET, Tavanur

19/08/19  
**EXTERNAL EXAMINER**



ACKNOWLEDGEMENT

**ACKNOWLEDGEMENT**

First of all, I offer million gratitude to **God**, the almighty who made me do this task and made every job a success for me. He was the greatest source of all resources and provision, moral or without whose grace nothing is possible.

It is my proud privilege to express my devout gratitude and indebtedness' to my chairman **Dr. Jayan P.R.**, Professor and Head (FMPE), KCAET, Tavanur for his thoughtful guidance, constant fomenting, punctilious and impeccable advices throughout the course of present study, which inspired me to carry out the research work in time. It is a matter of pleasure to glance back and recall the path one traversed during the days of hard work. It is still great at this juncture to recall all the faces and spirits in the form of teachers, friends, near and dear ones. I would consider this work nothing more than incomplete without attending to task of acknowledging the overwhelming help I received during this endeavor of mine.

I would like to express my heartfelt gratitude to **Dr. Hajilal M.S.**, former Dean i/c, Kelappaji College of Agricultural Engineering and Technology, Tavanur, for his interest and kind advice given to me at all stages of my study.

It is my pleasure to pay tribute to **Dr. Sathian K.K.**, Dean (Ag. Engg.) i/c, Kelappaji College of Agricultural Engineering and Technology, Tavanur, for his advice and guidance rendered during this study.

I place my special thanks to, **Dr. Shaji James P.**, Professor, **Er. Shivaji K.P.**, Assistant Professor, **Er. Sindhu Bhaskar**, Assistant Professor and **Er. Suma Nair**, Assistant Professor, Department of Farm Machinery and Power Engineering, KCAET, Tavanur.

I avail this opportunity to express my sincere thanks to my advisory committee members **Dr. Manoj Mathew**, Professor (FPM) RRS, Mancompu, **Dr. Suresh Kumar, P.K.**, Professor, Dept. of Agrl. Engg. CoH, Vellanikkara, **Er. Shivaji K.P.**, Assistant Professor, Department of Farm Machinery and power engineering, Kelappaji College of Agricultural Engineering and Technology, Tavanur and **Dr. Sasikala D.** Professor & Head, Dept. of IDE, KCAET, Tavanur

for their valuable counsel, note-worthy guidance and cordial co-operation during my research programme.

I offer my sincere and well devoted thanks to **Dr. Siva prasad**, Professor, Department of Ship Technology, CUSAT, Kochi and **Mr. Uday kumar**, Mac.N.Hom System, Kochi for their kind guidance and great support.

I extend my earnest thanks towards **Dr. Manoj kumar**, Senior Scientist, CIFT, **Dr. Sreelatha**, Professor, RRS, Vytilla, **Er. Avish A.C.** Assistant Professor (contract) and **Er. Shamin M.K.**, Assistant Professor (contract) for their immense helps and deemed support to complete the research successfully.

I express my sincere and well devoted thanks to **Er. Basavaraj patil**, Ph. D. Scholar, Dept. FMPE for his valuable suggestions, helpful advice and helped to carry out the research outcomes and its interpretations.

I also feel happy to express my heartfelt thanks to my nearest and dearest friends **Ms. Anusha H.R.**, **Ms. Ramyashree S.**, **Mr. Madhu M.**, **Mr. Naveen C.S.**, **Mr. Narayana Swamy R.**, **Mr. Sunil A.S.**, **Mr. Rajesh** and **Mr. Raghu** for them boundless help and caring me in every step of my studies and research work, with them support.

I would like to place my special thanks to my close friend **Er. Chethan B.J.**, **Er. Venkata sai K.**, **Er. Nathi Naga Hari Sai Ram**, **Er. Sreedhara B.** and **Er. Uday bhanu Prakash** for his sincere help and support during my study.

I also wish to thank our senior friend **Er. Dipak S. Khatawkar**, Ph. D. Scholar, Dept. FMPE for his kind support and guidance.

My completion of this project could not have been accomplished without the support of my classmates especially, **Er. Pooja M.R.**, **Er. Pooja V.**, **Er. Shahama**, **Er. Shahemath**, **Er. Rashmi**, **Er. Athira Prasad**, **Er. Ramya R.**, **Er. Akhila J. Chand** and **Er. Ashwathi** for their suggestion and invaluable help during my study.

I would like to thank my juniors **Bandi Nageshwar** and **Prasang** for their invaluable help during soil testing.

I express my thanks to all the faculty **members of library**, KCAET, Tavanur, for their ever willing help and cooperation. I express my sincere thanks and gratitude to **Kelappaji College of Agricultural Engineering & Technology** for giving me an opportunity to undergo my P.G studies and **Kerala Agricultural University** for having proffered me a chance to study in this institution.

Words are inadequate to express my heartfelt gratitude to my beloved parents **Sri. Krishna Reddy H.V. and Smt. Sarojamma K.V.** for their everlasting love and affection, help, support, incessant motivation and constant encouragement throughout my life.

Words are inadequate to express my heartfelt gratitude to my beloved uncle, aunty and brother-in-law. **Sri. Narayana Reddy C., Smt. Subbamma, Srinivas Reddy S. and Narasimha Reddy C.N.** for their everlasting love and affection, help, support, incessant motivation and constant encouragement throughout my life.

I am greatly indebted to my lovely sisters **Lavanya and Sukanya** for their everlasting love and affection, help, support, valuable advice, incessant motivation and constant encouragement throughout my life.

I have been highly fortunate and lucky to express my heartfelt respect to my dearest sisters and my relatives for their kind blessings and well wishes showed on me.

One last word; since it is practically impossible to list all contributions to my work, it seems proper to issue a blanket of thanks for those who helped me directly or indirectly during the course of my study.

Venkata reddy - H.K.  
VENKATA REDDY H.K.



## ***DEDICATION***

This thesis is dedicated to my God, Parents and Guide, who sacrificed much to bring me up to this level and to my lovely sisters, friends and their families for the devotion they made to make my life successful.

## CONTENTS

Chapter No.	Title	Page No.
	LIST OF TABLES	i
	LIST OF FIGURES	ii
	LIST OF PLATES	iv
	APPENDICES	v
	SYMBOLS AND ABBREVIATIONS	vii
I	INTRODUCTION	1
II	REVIEW OF LITERATURE	4
III	MATERIALS AND METHODS	17
IV	RESULTS AND DISCUSSION	73
V	SUMMARY AND CONCLUSION	88
	REFERENCES	92
	APPENDICES	98
	ABSTRACT	

**LIST OF TABLES**

<b>Table No.</b>	<b>Title</b>	<b>Page No.</b>
4.1	Specification of float of the existing prototype	75
4.2	Specification of hydraulic motor	77
4.3	Specification of cutting unit of the existing prototype	78
4.4	Specification of front conveyor of the existing prototype	79
4.5	Specification of center conveyor of the existing prototype	80
4.6	Specification of float of the scale down prototype	82
4.7	Specification of cutting unit of the scale down prototype	84
4.8	Specification of front conveyor of the scale down prototype	85
4.9	Specification of center conveyor of the scale down prototype	86

**LIST OF FIGURES**

<b>Fig. No.</b>	<b>Title</b>	<b>Page No.</b>
3.1	Orthographic view of KAU Pokkali paddy harvester	22
3.2	Floating barge of the existing prototype	25
3.3	Air chamber of the existing prototype	26
3.4	Traction belt of the existing prototype	27
3.5	Grouser of the existing prototype	28
3.6	Paddle of the existing prototype	30
3.7	Hydraulic circuit of the KAU Pokkali paddy harvester	31
3.8	Hydraulic cylinder	33
3.9	Reel assembly of the existing prototype	37
3.10	Knife section of the cutter bar of the existing prototype	40
3.11	Front conveyor of the existing prototype	41
3.12	Center conveyor of the existing prototype	45
3.13	Floating barge of the scale down prototype	50
3.14	Air chamber of the scale down prototype	51
3.15	Traction belt of the scale down prototype	52
3.16	Grouser of the scale down prototype	53
3.17	Paddle of the scale down prototype	55
3.18	Reel assembly of the scale down prototype	58
3.19	Knife section of the cutter bar of the scale down	61

---

	prototype	
3.20	Front conveyor of the scale down prototype	62
3.21	Center conveyor of the scale down prototype	66
3.22	Top view of the scale down prototype	70
3.23	Side view of the scale down prototype	71
3.24	Isometric view of the scale down prototype	72
4.1	Stability aspects of the harvester	81

---

**LIST OF PLATES**

Plate No.	Title	Page No.
1.1	Conventional practices of harvesting of Pokkali paddy crop	2
2.1	Hydraulic system drive	13
2.2	Hydraulic circuit	13
2.3	a) Stable equilibrium, M is above G b) Unstable equilibrium, M is below G	15
3.1	In-situ measurement of shear strength	20
3.2	In-situ measurement of soil resistance	21
3.3	Working of KAU Pokkali paddy harvester in fields	23
3.4	Gerotor motor	34
3.5	Direction control valves	35

**LIST OF APPENDICES**

<b>Appendices No.</b>	<b>Title</b>	<b>Page No.</b>
I	Determination of moisture content	98
II	Determination of bulk density	99
III	Determination of shear strength	100
IV	Determination of soil resistance	101
V	Determination of physical properties of Pokkali soil	102
VI	Determination of chemical properties of Pokkali soil	102
VII	Specifications of existing KAU Pokkali paddy harvester	103
VIII	Design of hydraulic system	105
IX	Selection of prime mover of the existing prototype	108
X	Selection of prime mover of the scale down prototype	111
XI	Centre of gravity of the components of KAU Pokkali paddy harvester	114
XII	Centre of gravity of the components of scale down Pokkali paddy harvester	117
XIII	Specification of scale down prototype of the Pokkali paddy harvester	120
XIV	Function diagrams of hydraulic motors	121
XV	Power transmission circuit diagram of the Pokkali paddy harvester	122

---

XVI	Components of existing KAU Pokkali paddy harvester	123
XVII	Components of scale down prototype of Pokkali paddy harvester	137
XVIII	Cost estimation of the scale down Pokkali paddy harvester	153

---



## SYMBOLS AND ABBREVIATIONS

Symbols	:	Abbreviations
<	:	Less than
>	:	Greater than
%	:	Per cent
±	:	Plus or minus
×	:	Multiplication
÷	:	Division
≤	:	Less than or equal to
≥	:	Greater than or equal to
°	:	Degree
°C	:	Degree centigrade
ASAE	:	American Society of Agricultural Engineers
CI	:	Cone index
Cm	:	Centimeter
cm <sup>2</sup>	:	Square centimeter
cm <sup>3</sup>	:	Cubic centimeter
cc rev <sup>-1</sup>	:	Cubic centimeter per revolution
Db	:	dry basis
et al.	:	and others
etc.	:	et cetera
Fig.	:	Figure

---

G	:	Gram
g cm <sup>-3</sup>	:	Gram per cubic centimeter
GI	:	Galvanized iron
H	:	Height
Ha	:	Hectare
Hp	:	Horse power
Hr	:	Hour
ha hr <sup>-1</sup>	:	Hectare per hour
IS	:	Indian standards
KAU	:	Kerala Agricultural University
KCAET	:	Kelappaji College of Agricultural Engineering and Technology
Kg	:	Kilogram
kg cm	:	Kilogram centimeter
kg cm <sup>-2</sup>	:	Kilogram per square centimeter
kg ha <sup>-1</sup>	:	Kilogram per hectare
kg m	:	Kilogram meter
kg m <sup>-3</sup>	:	Kilogram per cubic meter
Kgf	:	Kilogram force
Km <sup>2</sup>	:	Kilometer square
km h <sup>-1</sup>	:	Kilometer per hour
kN	:	Kilo newton

---

---

kN.m <sup>2</sup>	:	Kilo newton per meter square
Kw	:	Kilo watt
L	:	Length
l min <sup>-1</sup>	:	Litre per minute
M	:	Meter
m min <sup>-1</sup>	:	Meter per minute
m s <sup>-1</sup>	:	meters per second
m <sup>2</sup>	:	Square meter
m <sup>3</sup>	:	Cubic meter
Mm	:	Millimeter
mm <sup>2</sup>	:	Square millimeter
MS	:	Mild steel
N	:	Newton
N cm <sup>-2</sup>	:	Newton per square centimeter
N m <sup>-1</sup>	:	Newton per meter
Nm	:	Newton meter
pH	:	Potential of hydrogen
Rpm	:	Revolutions per minute
rad s <sup>-1</sup>	:	Radian per second
Sl. No.	:	Serial Number
T	:	Tons
viz.	:	Namely

---

---

$W$	:	Width
$W_b$	:	Wet basis
$\alpha$	:	Alpha
$\theta$	:	Theta
$\mu$	:	mue
$\pi$	:	Pi
$\rho$	:	Rho
$\eta$	:	Efficiency

---

INTRODUCTION

## CHAPTER - I

### INTRODUCTION

The term 'Pokkali' used in the common parlance refers to a salt tolerant traditional rice cultivar grown in the coastal saline soils of Kerala, India. This peculiar system of rice cultivation in vogue in this tract is also known by this rice cultivar as "Pokkali system".

#### 1.1 IMPORTANCE OF POKKALI CULTIVATION

The Pokkali field is a unique eco system prevailing in the coastal tract of Kerala with rich bio diversity and amazing capacity to produce organic rice and shrimp alternatively. Rice is grown during non-saline period and the farmers carry out shrimp culture during the saline phase with both having unique symbiotic benefits. Rice plants get their nutrients from the left over of the shrimps and the shrimps in turn, feed on the stalks and decaying remnants of the rice crop. Neither chemical fertilizers nor insecticides and pesticides are used. The usual ploughing and transplantation are not required for Pokkali.

#### 1.2 AREA, PRODUCTION AND PRODUCTIVITY OF POKKALI RICE IN KERALA

Pokkali area lies in Trissur, Ernakulum and Alappuzha districts of Kerala spreads in a total area of 8500 ha. It spreads over 34 Krishibhavans of these three districts. In the saline, water-logged Pokkali farm lands, rice and shrimps are farmed alternatively. In more than 90% of the single cropped lands, rice cultivation is done during the low saline phase from May/June to September/October; the traditional prawn filtration is taken up during the high saline phase which sets in December/January.

The Pokkali paddy varieties are having early seedling vigour and attain a height of 40-45 cm in 30-35 days. At this stage, when field conditions become favourable the mounds are made and a few seedlings are uniformly spread on the beds in the field. The clods give anchorage to the seedlings. Generally manuring

and plant protection operations are not necessary for Pokkali farming systems. The crop matures at about 120 days. The ear heads alone are harvested, leaving the straw behind in the fields. The average yield of rice with traditional rice varieties is 1500 kg ha<sup>-1</sup>. The conventional method of harvesting of Pokkali paddy crop is by using sickles. The various farming operations in Pokkali paddy cultivation, the harvesting is done by women labourers by walking on the swampy and marshy inundated paddy fields at waist-deep water, which is laborious, tedious and cumbersome.



**Plate 1.1 Conventional practice of harvesting of Pokkali paddy crop**

Due to these naturally adverse conditions prevailing in these lands and the non-availability of labourers, the paddy cultivation goes on decreasing every year. Hence, there was a great demand for a suitable harvesting machine, especially for harvesting the paddy, which is under water at the time of harvest due to tidal effects. Though a number of paddy combine harvesters are commercially available, none cannot be used in such marshy water logged areas for harvesting paddy. Hence a power operated floating harvester, 'KAU Pokkali paddy harvester' with provisions for harvesting and conveying the ear heads of water submerged paddy stalks was developed and tested in a project at KCAET, Tavanur.

The harvester mainly consists of a floating barge, hydraulic system and harvesting units. The floating barge consists of floats, air chamber, propeller and traction belt with grousers. Hydraulic system includes hydraulic cylinders, motors and pump, while the harvester consists of a reel, cutter bar and conveyors. The floats are used to float the harvester on water and traction belts are provided to move the harvester on soil using grousers. The hydraulic cylinders help to lift the front conveyor, cutter bar and reel assembly. Separate hydraulic motors were used to operate cutter bar, front conveyor, centre conveyor and floats. Reel delivers the stalks to the cutting mechanism, holds upright during cutting and delivers the cut stalks to the transport mechanism. Cutter bar is a component to cut the stalk. The drive to the cutter bar is given through a crank- pitman mechanism. The cut stalks is then conveyed to the lugged belt conveyors.

The overall size of the harvester is 9.6 x 2.2 x 2.2 m with a total weight of three tonnes. Due to the over size and weight, the manoeuvrability become a great problem for transportation and operation in small paddy lands. It necessitated designing a scale down proto type of the harvester to operate in all Pokkali areas with easy transportation and good manoeuvrability features. Moreover, its design analysis using appropriate software could suggest suitable materials for various parts and generate drawings of its functional components. Also, the study of stability aspects of the harvester considering buoyancy, floatation and traction parameters will ensure a proper design for a scale down prototype of the KAU Pokkali paddy harvester. In view of the above factors, a research programme was undertaken with the following objectives:

1. To study physical and mechanical properties of Pokkali soil
2. To study design features of the KAU Pokkali paddy harvester
3. To design a scale down prototype of the Pokkali harvester



REVIEW OF LITERATURE

## CHAPTER - II

### REVIEW OF LITERATURE

This chapter gives a comprehensive review of research work done by many research workers and briefed as Pokkali paddy cultivation, physical and mechanical properties of soil, paddy harvesters and stability of floating systems.

#### 2.1 Pokkali paddy cultivation

Manorama and Padma kumar (1999) conducted a study on Kuttanad low lying area with backwaters, canals and stream networks extending over 874 km<sup>2</sup>. There are garden lands of average elevation of 1.0 m above mean sea level covering an area of 304 km<sup>2</sup>. Kuttanad, the deltaic formation of four major river systems, Pampa, Achenial, Manimala and Meenachil, confluence into the Vembanad lake, lies 0.6 to 2.2 m below mean sea level. The region extends from 9°17' to 9°40' N latitude and 76°19' to 76°33' E longitude. Rice is the important agricultural product, giving Kuttanad the moniker of "The Rice Bowl of Kerala". The garden lands, or the reclaimed purayi dams or homesteads with coconut groves, fringed by canals and channels make this a land of richness and beauty.

Pillai (2003) conducted a study on fishery and production of shrimps from perennial and seasonal fields of Kerala. During high tides, the water entered into the pokkali fields through the sluice in twice daily. During night, the mouth of the sluice was fitted with bulbs / hurricanes / petromaxes etc. for attracting shrimp seeds into the fields. Water was let out from the field for a period of about one hour based on the tide, water flow and depth of the field.

Gayatri and Raveendran (2009) conducted a study on Exploration of untapped potentiality of coastal paddy fields of Kerala. Study showed that the Kuttanad area remains submerged for greater part of the year and is dewatered after the monsoon is over. There were special large sluice gates which were operated to allow the flood water to flow into the sea and to prevent the sea water flooding the lake. Popular in the coastal belt of the State, nearly two-third of the Pokkali cultivation is in Ernakulum district. It is estimated that nearly 20,000 ha

of saline soils are under paddy cultivation in Ernakulum, 2,000 ha in Alappuzha and 2,000 ha in Kannur. All the other coastal districts put together have about 1,400 ha of land under cultivation. In order to survive in the water logged field, the rice plants grow up to two meters. But as they mature, they bend over and collapse with only the panicles standing upright. While harvesting, only the panicles are cut, and the rest of the stalk are left to decay in the water, which in time become feed for the prawns.

Jayan and Sathyanathan (2010) conducted a study on overview of farming practices in the water logged areas of Kerala. Studies reviewed that the fields are situated below the mean sea level and having the problems of water-logging and have no addition of chemical pesticides or fertilizers in the Pokkali rice fields which make them different from the other farming practices in Kerala.

Sasidharan *et al.* (2012) conducted a study on spatial and temporal integration of rice, fish, and prawn in the coastal wetlands of central Kerala, India. The traditional system of growing tall rice (*Oryza sativa*) varieties during the monsoon season and prawn culture (prawn filtration) during summer season, locally known as Pokkali, is a sustainable system of production harmoniously blended with natural processes like sea water inundation in the low-lying coastal zones of Kerala. Varieties of seeds has Culture-1026 showed better growth and yield (4391 kg ha<sup>-1</sup>) over VTL3 (2434 kg ha<sup>-1</sup>) and 'Chettivirippu' mutant (3950 kg ha<sup>-1</sup>).

Vanaja (2013) conducted a study on KAIPAD –a unique, naturally organic, saline prone rice ecosystem of Kerala, India. A complex and ecologically responsive rice-fish farming system has evolved in the coastal wetland regions of India over centuries. Kaipad is a unique coastal wetland rice production tract which is saline prone and naturally organic production tract of North Kerala, India which was not much known to the scientific world. The rice produce from this particular ecosystem is purely organic. Apart from integrated organic farming system in which rice cultivation and aquaculture go together, Kaipad ecosystem is featured with rich biodiversity of flora and fauna, organically rich soil, mangroves, and migratory birds. The Pokkali tract of south Kerala is said to be

synonymous to Kaipad tract of North Kerala. But soils of Kaipad slightly differ from that of Pokkali. Rice farming in Kaipad is carried out in a peculiar way, purely in a natural way relying on the monsoon and the sea tides. Besides its own saline tolerant land races of rice, recently high yielding rice varieties were developed for Kaipad tract by Kerala Agricultural University utilizing the traditional land races. Even though the product from Kaipad is purely organic nothing much has been done to explore the value of organic rice for the benefit of farmers. Besides research accomplishment, a comprehensive multi faced development approach is necessary to preserve, protect and develop this unique organic rice bowl of Kerala, governed by small and marginal farmers.

Abhilash Joseph (2016) conducted a study on rice cultivation in saline tracts of Kerala. This paper is an effort to review the significance of present the Pokkali and Kaipad systems of rice cultivation in Kerala, since the wetlands under rice-fish farming have been facing severe threats due to a variety of factors. The factors include shift from the ecologically fragile rice-fish farming to semi intensive fish farming Salinity effects and problems with regard to rice farming and crop productivity. It provided information on the impact of salinity on agriculture and global distribution of salinity. Also reported that thirty seven percent of rice production in the state is contributed by the lowland ecosystems.

## **2.2 Physical and mechanical properties of Pokkali soil**

Jackson (1958) conducted sampling analysis of soils collected from the bottom surface by Van veen grab. Sampling of sediment was done at four points from each station. The collected samples were mixed and then were air dried, ground to fine powder by using mortar, and stored in air tight polythene bags for analysis. pH and electrical conductivity were measured immediately after the collection following standard methods.

Steven and Omi (1985) found out the compaction effects of soil on its the properties. Study revealed that penetrometer resistance decreased as moisture content (at the time of compaction) of sandy loam increased and in unsaturated sandy soil, bulk density increased as applied load (range 60 to 360 kPa) increased.

Water content on compaction also affected by soil texture. Sandy clays may compact to 1.7 to 2.1 g.cm<sup>-3</sup> at only 8 to 15 per cent moisture, clays to 1.5 to 1.7 g.cm<sup>-3</sup> at 20 to 30 per cent moisture. Seedling establishment was generally > 75 per cent on a sandy loam, regardless of compaction intensity (1.2, 1.4, 1.6, and 1.8 g.cm<sup>-3</sup>); on a silt loam, only soil compacted to 1.8 g.cm<sup>-3</sup> significantly reduced seedling establishment. Length of primary root penetration of *Pseudotem* declined to 71 to 87 per cent as bulk density increased from 1.38 to 1.76 g.cm<sup>-3</sup>. Study resolved that compaction can detrimentally affect soil physical characteristics, resulting in poor tree growth.

Blake, G.R. and Hartge (1986) studied the physical properties of soil. They found out that the variation in bulk density is attributable to the relative proportion and specific gravity of organic and inorganic particles and its porosity. Most mineral soils had bulk densities between 1.0 and 2.0 g cm<sup>-3</sup>.

Grigal *et al.* (1989) studied about bulk density of surface soils and peat in the north central United States. They also mentioned that a very compacted soil perhaps due to tractor compaction would have a bulk density of 1.4 to 1.6 g cm<sup>3</sup> and an open friable soil with good organic matter content will have a bulk density of <1.0 g cm<sup>3</sup>. Although bulk densities are seldom measured they are very important in quantitative of soil and nutrient status of terrestrial ecosystem study

Brandelik and Hiibner (1996) developed electromagnetic measurement techniques of soil moisture. He used three different sensors, which enriched the accuracy of measurement device and extend the range applications. The first one was in-situ sensor, which evaluated soil moisture profile down to 2.5 m with a vertical resolution of 3 cm and accuracy was 1.5 unconditional volumetric water content. The second sensor measured accurately the water content in the surface layer of the soil. Third sensor was a moisture sensitive cable. It used the technique of time domain reflectometry and frequency domain reflectometry.

Reddy (2002) conducted an experiment on engineering properties of soils based on laboratory testing. The test was conducted to determine the physical and

mechanical properties of soils like moisture content, bulk density and grain size. He mentioned that water content is the ratio, expressed as a percentage, of the mass of "pore" or "free" water in a given mass of soil to the mass of the dry soil solids. The bulk density is the ratio of mass of moist soil to the volume of the soil sample and the dry density is the ratio of the mass of the dry soil to the volume the soil sample. Grain size analysis was performed to determine the distribution of different grain sizes and hydrometer method was used to determine the distribution of the finer particles.

Adeniran and Babatunde (2010) conducted a study on investigation on wetland soil properties affecting optimum soil cultivation. A cone penetrometer and a shear vane apparatus (19 mm) were used to determine the cone index and the torque that cause the soil to shear at different moisture contents. The study showed that the cone index increased with depth and decreased with increase in moisture content. High moisture content reduced the soil cohesion. The internal frictional angle of the soil was 37.90. The following values were obtained for soil cohesion 112, 62, 38, 30 and 12 kN.m<sup>-2</sup> respectively at moisture contents of 0, 5, 10, 15 and 20 per cent. Moisture content between 10 -15 per cent (dry basis) appeared ideal for cultivation of the soil. For those soils the critical moisture content was found to be 23.72 per cent.

Bawatharani *et al.* (2013) conducted a study on impact of reel index on header losses of paddy and performance of combine harvesters. They investigated the effect of reel index and type of combine harvester on header losses when harvesting the long grain paddy varieties. The field experiment was carried out in a split plot design with three replications. Two brands of popular combine harvesters (Kubota DC-68G and Agro world 4L-88) and three levels of reel indices i.e. 1.2, 1.7 and 2.5, were assigned to the main and sub plots respectively. The results revealed greater header advancement and an increased tyne bar velocity at the reel index of 1.2 resulted in higher header losses in both combine harvesters. Similarly, lesser header advancement and increased number of impacts of the reel on panicles at the reel index of 2.5 also caused greater header

losses. The reel index of 1.7 resulted significantly low header losses of 38.8 and 45.8 kg ha<sup>-1</sup> from Kubota and Agro world harvesters respectively.

Antony *et al.* (2014) conducted a study on the effect of rotational Pokkali cultivation and shrimp farming on the soil characteristics of two different Pokkali fields at Chellanam and Kadamakudi, Kochi, Kerala. They found that the soil pH varied highly acidic to 7.15 slightly alkaline in Chellanam and alkaline in Kadamakudi. The least value of conductivity and salinity were occurred on the first half of the June. The highest value of total organic carbon was 1.05% in Chellanam and 6.225% in Kadamakudi observed on the second half of April. The highest value of phosphate was 0.1578 mg g<sup>-1</sup> in Chellanam and 0.2125 mg g<sup>-1</sup> in Kadamakudi with a mean and standard deviation of  $6.87 \pm 7.67$  and  $0.14 \pm 0.05$  respectively. The nitrogen content of the soil also showed the same trend as phosphate. The carbon content of the soil showed a slight increasing trend. The sulphur content of the soil is negligible and showed only 0.18 per cent.

Maly and Kucera (2014) conducted a study on determination of mechanical properties of soil under laboratory conditions. Two types of soil with different levels of moisture were examined and their mechanical properties were determined. Measurements were taken from a non-compressed soil. The force and penetration depth of the pressing plate were recorded simultaneously. Three different diameters of pressing plate were used, namely 38, 50 and 70 mm. The pressure on the contact area was calculated after completion of the measurements and the relationships between pressure and penetration depth were presented graphically.

### **2.3 Paddy harvesters**

The reel in a combine harvester delivers the stalks to the cutting mechanism, holds them upright during cutting and pushes the cut crop towards the platform conveyor. Pick up reels were used for lodged crops that have fallen over due to heavy rains, winds, etc. to pick them up for cutting. Optimum reel position was determined by the crop height, amount of straw cut, and the condition of the

straw. Normally, the reel should be set so the slats, when in their lowest position, will strike the straw 15 to 25 cm above and slightly ahead of the cutter bar (Oduori, 1994).

Celik (2001) developed a push type cutter bar mower for forage harvesting. The cutter bar mower consisted of six main components including the cutting, transmission, power, handling, frame, and transporting units. A two stroke engine that produced 1.47 kW at 7000 rpm provided power for the cutting unit. Two skids were attached to the cutter bar unit, one on each side to control cutting height. The total mass of the mower was 41 kg. Performance tests of the mower resulted in an average 0.11 ha h<sup>-1</sup> effective field capacity.

Bautista *et al.* (2005) designed a rotary cutting reaper for rice. Their purpose was replacing the reciprocating cutter bar assembly with a rotary cutting system borrowed from grass cutters. These rotary cutters required fewer blades and less manufacturing tolerance. The laboratory studies inferred that the number of blades per disc was set for tip speed of 23- 30 m s<sup>-1</sup> and forward speed ranged from 2.8 to 3.3 km h<sup>-1</sup>.

Ananth *et al.* (2013) reported that the belt conveyor is used for the transportation of material from one location to another. Belt conveyor has high load carrying capacity, simple design, easy maintenance and high reliability of operation. Belt conveyor system is also used in material transport in foundry shop like supply and distribution of molding sand, grains and removal of waste. This study provided the to design of a conveyor system viz. includes belt speed, belt width, motor selection, belt specification, shaft diameter, pulley, gear box selection using standard methods.

Arman Jalali and Reza Abdi (2014) conducted an experiment on the effect of ground and reel rotational speed and height on harvester losses. A factorial experiment based on completely randomized design with nine replications was carried out. Three main treatments for this study were considered. Treatments consisted of ground speed (V) at three levels (1, 2 and 4 km h<sup>-1</sup>), the reel rotation



speed (W) at three levels (25, 32 and 40 rpm) and the reel height (H) at three levels (87, 110 and 118 cm). The results showed that ear loss of three treatments, interaction of  $V \times W$  and the triple interaction of  $V \times W \times H$  were significant ( $P \leq 0.01$ ). Ground speed was the only significant factor effecting seed loss ( $P \leq 0.01$ ). The study showed that maximum loss occurred at the highest ground speed and rotational speed of reel. The best treatment at a ground speed of  $1.0 \text{ km h}^{-1}$  reel rotational speed of 25 rpm and a height of 87 cm.

Ephrem, Z. K. and Ing Zewdu, A. (2014) conducted a study on design and modification of appropriate reel mechanism to harvest Tef Crop. The relationships between the deflection angle and deflection force acting on a bunch of crop stalk in the gathering operations of a combine harvester reel were analysed. Mechanical crop model based on bending theory with regard to an elastic beam were applied in this analysis. In the model, the effect of flexural rigidity, crop ear weight and reel force on tef crop stalk in the angle of deflection. A model of crop stem deflection by the combine harvester reel was formulated. Applications of crop stem deflection to reel design and operation were used for determination of the number of reel tyne bar and angular displacement of successive tyne bar. The reel design included the determination of the number of tyne bar, angular displacement of the reel and rotational speed of reel.

#### **2.4 Hydraulic system**

Darling and Tilley (1999) studied the combine harvester, it consist of principal circuit and a steering circuit. The principal circuit operated three actuators connecting with height control of both cutting platform and reel, also moves variable sheave in order to vary ground speed and steering circuit steers the machine. The only common point of two circuits is their pump, in which is a priority valve in order to first supply the needed oil to the steering circuit, then it delivers the rest oil to the another circuit. Other components of the circuit are thoroughly separated. Segregation of hydraulic circuits is an acceptable method but in order to achieve significant improvements in system efficiency, using a concentrated circuit is possible.

Pumps are well-known as the heart of a hydraulic system. They allow flow of oil towards the actuators. They turn hydraulic force into rotary or reciprocating forces consequently displacement or rotation of the intended part is provided, (Dalayeli and madineh, 2002).

Mullen and Williams (2004) exploited survey data that reported annual maintenance/repair expenditures for Canadian manufacturing industries and indicated that the cost of capital, among other variables, has a statistically significant effect on maintenance/repair decisions.

Wang Jiwei *et al.* (2005) conducted a research on hydraulic and pneumatic transmission. Hydraulic drive chassis includes engine, variable hydraulic pump, fuel tank, digital hydraulic cylinder, hydraulic motor, manual valve and other components are shown in the plate 2.1. The engine connected to the variable hydraulic pump by belt transmission drive the hydraulic pump which draws oil from the fuel tank and convert mechanical energy into pressure. The hydraulic pump provides power for two digital cylinders and the two hydraulic motors by tubing. By controlling three position four-way directional control valve manually walking three working position to realize mechanical forward backward and parking. A sensor is arranged at the front end of the wheel, and the left and right expansion of the digital hydraulic cylinder is adjusted by the pulse signal which is fed back by the sensor, and the left and right movement of the driving wheel is realized. Thus the direct contact between the walking machine and the obstacle, and the failure rate of the vehicle is effectively reduced. At the same time, it is equipped with a relief valve with the function of overload protection and hydraulic auxiliary components such as filter, cooler, guarantee the normal work of the system.

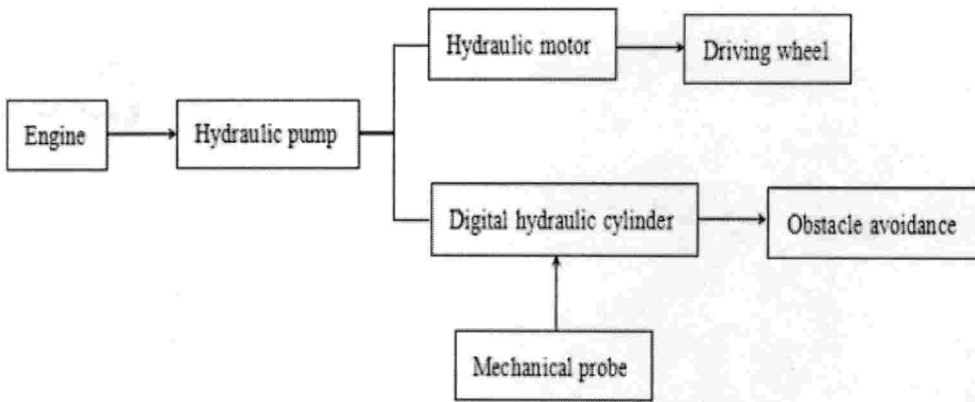

**Plate 2.1 Hydraulic system drive**

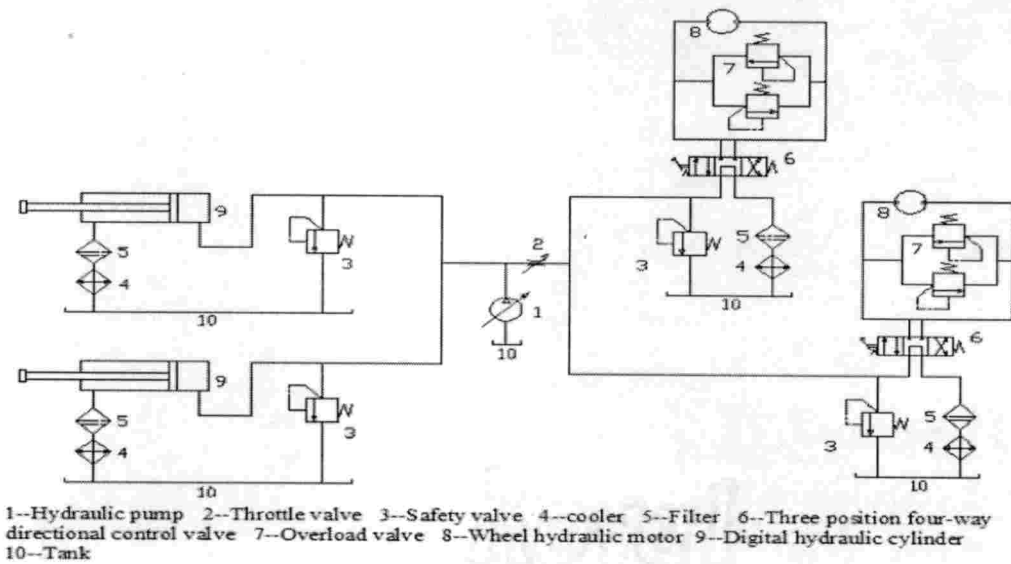

**Plate 2.2 Hydraulic circuit**

Gamez-Montero *et al.* (2009) studied analytical and experimental investigations of typical hydraulic cylinders indicated that their load capacities are significantly different from those obtained from simple buckling analysis of idealized systems. In any case, an increase in the friction coefficient at the restrained ends changes the actuator's limit load; while an increase the initial maximum deflection decreases the limit load. A common practice of most cylinder manufacturers is to use a safety factor between 2.5 and 4 to determine the service load after the critical load is obtained by simple analytical procedure striating the cylinder as a perfect stepped column.

Jiang, Y. and Zou, G. (2009) revealed that low speed high torque hydraulic motor mainly includes vane hydraulic motor and radial piston hydraulic motor. The vane hydraulic motor can keep stable in the process of low speed rotation and harsh environment conditions. Radial piston hydraulic motor has the advantages of high volumetric efficiency, large starting torque and stronger adaptability. The performance of hydraulic motors depends upon many factors such as precision of their parts, tolerances between the mating parts, etc. Internal leakage between the inlet and outlet affects the volumetric efficiency. Friction between mating parts affects the mechanical efficiency of a hydraulic motor. Gear motors have an overall efficiency of 70–75% as compared to vane motors which have 75– 85% and piston motors have 85–95 per cent overall efficiency.

Xie Fuxiang (2014) stated that the hydraulic valve as a hydraulic system control component used to control the flow direction and hydraulic pressure. The implementation of components and driven work machine were used to obtain the desired direction of movement, thrust (torque) and velocity (speed), etc., to meet the requirements of different actions. A working process and the quality of the hydraulic system, largely depends on various hydraulic valves.

Jignesh, V. and Hitesh, R. (2016) studied on modelling and analysis of telescopic hydraulic cylinder for increased load capacity. Hydraulic cylinders are normally designed for working pressures of up to 350 - 400 bars and occasionally up to 600 bar and more for special purposes. Apart from its function to a linear hydraulic motor, the cylinder is also structural element. As structural element it must not only generate forces but also absorb forces. The hydraulic cylinder, as a linear motor and structure element, is greatly influenced by environmental circumstances. Elements such as temperature, humidity and corrosive influences lamely determine to what extent the cylinder comes up to one's expectations and are therefore decisive with respect to quality.

Hydrostatics concerns the conditions to which the vessel is subjected while at rest in water and to its ability to remain a float. This involves computing

buoyancy, displacement, and other hydrostatic properties such as trim (the measure of the longitudinal inclination of the vessel) and stability (the ability of a vessel to restore itself to an upright position after being inclined by wind, sea, or loading conditions). (www.usna.edu).

## 2.5 Stability of floating harvester

Giles *et al.* (1994) conducted a study on stability of a floating body is divided in two different types, vertical and rotational. A floating body has vertical stability but its rotational stability depends upon the positions of centre of gravity (G) and centre of buoyancy (B). If G is below B the equilibrium is stable. But if G is above B the equilibrium may or may not be stable. The usual method in specification of stability of a floating body is finding the metacentre point and then comparing its position with G. The equilibrium is stable if the metacentre lies above G.

Bansal (2005) conducted a study on a floating body. It said to be stable if it comes back to its original position after slight disturbance, two alternate moments may act on the floating body depending on the relative position of centre of gravity (G) and centre of buoyancy (B).

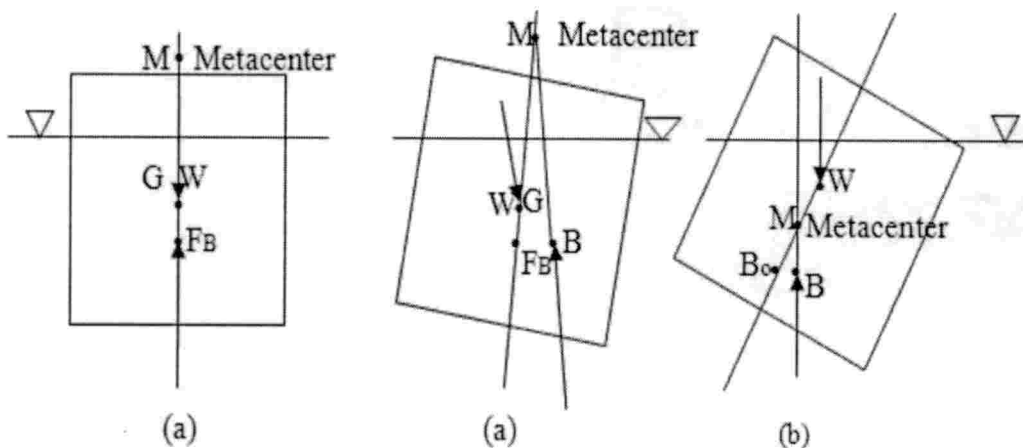

**Plate 2.3 (a) Stable equilibrium, M is above G (b) Unstable equilibrium, M is below G**

Mohammad (2011) conducted a study on the stability of floating bodies. The potential energy of a system in stable equilibrium has a minimum value. This property is used to derive a formula that is useful in determination of stability of a floating body. It is found that a floating body is in stable equilibrium if its centre of gravity has a minimum height with respect to its related centre of buoyancy.

Omofunmi *et al.* (2016) conducted a study on design of water hyacinth (*Eichhornia crassipes*) harvester. The purpose of this study was to design a harvester for control of water hyacinth. The anatomy and physiology of the water hyacinth were used to design the machine using basic engineering procedures. The main parts of the water hyacinth harvester included an electric motor (2.0 hp), mower disc (100 x 70 x 7.36 mm), shaft (26 mm diameter) with 4 blades made of stainless steel. The machine operates with capacity of 10,646 tons hr<sup>-1</sup> at the speed of 3.04 m s<sup>-1</sup>. The capacities of the loading and delivery conveyors are 846.60 and 538.75 tons hr<sup>-1</sup> respectively. Fabrication of the designed water hyacinth harvester, using local materials will promote and enhance indigenous technologies that will improve physical control of the plant. The water hyacinth harvester is also known as aquatic scavenger. The harvester is a boat which is capable of cutting and carrying the harvested weeds to the shore. The water hyacinth harvester was designed, fabricated and tested on laboratory. The average harvesting capacity was found to be 6.5 t/hr/m width of the conveyor when the traveling speed was 0.56 km hr<sup>-1</sup>.

*MATERIALS AND METHODS*

## CHAPTER - III

### MATERIALS AND METHODS

In this chapter the methods followed to determine the physical and mechanical properties of Pokkali soil are explained. The design analysis of Pokkali paddy harvester is carried out separately for floating barge, hydraulic and harvesting system. Also the design of the scale down proto type is dealt separately.

#### 3.1 PHYSICAL, CHEMICAL AND MECHANICAL PROPERTIES OF THE SOIL

The physical and mechanical properties of soil affecting the design analysis of Pokkali paddy harvester were studied. The four major soil properties, viz, moisture content, bulk density, shear strength and soil resistance affecting the traficability to the Pokkali paddy harvester were determined in the present study. Soil samples from different locations of the Pokkali fields were collected in containers to determine the above mentioned properties of the soil. The tests were conducted in the Soil and Water Laboratory at RRS, Vyttila and KCAET, Tavanur.

##### 3.1.1 Moisture content

Moisture content (W) is the ratio of the weight of water to the weight of the solids. The moisture content of the sample in per cent dry basis was determined by using the equation,

$$MC (\%) = \frac{W_i - W_d}{W_i} \times 100 \quad \dots 3.1$$

Where,

$W_i$  is initial weight of the soil, g

$W_d$  is dry weight of the soil, g



It is expressed in percentage and is found out by oven dry method. Soil samples of six different locations of the Pokkali fields were collected at depths of 10-20 cm. The soil samples of 350 g each were collected in different containers and placed in a hot electric oven under controlled temperature of 105°C for a time period of 24 hours (Angelis, 2007). The weight before and after drying was found out using an electronic weighing balance having a sensitivity of 0.01g. The determination of soil moisture content helped to find out water requirement.

The in-situ soil moisture content during the month of April 2018 was recorded using digital soil moisture meter (model – BST-SM400) having resolution of 0.1per cent. The moisture meter was inserted in a soil at a depth of 10 - 15 cm for about 30 seconds. The percentage of moisture content of the soil was displayed in the display board and was recorded.

### 3.1.2 Bulk density

The compactness of the soil is determined by measuring bulk density using core cutter method. The bulk density was found out by using the equation,

$$\text{Bulk density } (\rho) = \frac{M}{V} \quad \dots 3.2$$

Where,

$\rho$  – Bulk density, g cm<sup>-3</sup>

M – Mass of the soil, g

V – Volume of the soil, cm<sup>3</sup>

Initially volume of a cylinder (cm<sup>3</sup>) was determined by measuring the internal diameter (10cm) and height of core cutter (12.5cm). The weight of the empty core cutter was also measured.

A small area of 30 X 30 cm<sup>2</sup> of the soil in Pokkali field was exposed and surface was levelled. A cylindrical core cutter was pressed into the soil mass using the rammer with dolley placed over the top of the core cutter. Pressing was stopped when the dolley protrudes about 15mm above the soil surface.

Surrounding soil of core cutter was removed and it was taken out. Top and bottom surfaces of the core cutter were carefully trimmed using a straight edge. Core cutter filled with the soil was removed and weighed. Bulk density of the soil was determined by using equation (3.2).

### 3.1.3 Shear strength

Shear strength of a soil is the maximum resistance offered by the soil to shearing stresses (Awadhani and Singh, 1985). The Shear strength was found out by using the equation,

$$S = \frac{T}{\pi\left(\frac{D^2H}{2} + \frac{D^3}{6}\right)} \quad \dots 3.3$$

Where,

S = Shear strength, kg cm<sup>-2</sup>

T = Torque, kgf.cm

D = Overall diameter of vane, cm

H = Height of the vane, cm

If H = 2D the equation reduces to

$$S = \frac{3T}{11D^3} \quad \dots 3.4$$

The in-situ measurement of shear strength of soil was carried out using a vane shear test apparatus (Make – AIMIL (CIVIL)) arrangement as shown in Plate 3.1. Bore holes at depths of 30, 45 and 60 cm were dug out. Casing was extended up to these depths and hence the entire unit was fixed at the location during the test. Torque applicator was fixed on the stand with the help of spikes. A vane size of 37.5 mm diameter was selected and it was connected to the vane rod having same female thread. The vane was lowered to the above required depths. It was pushed downward with a moderate steady force up to a depth of 50mm below the bottom of the bore hole and allowed for 5 minutes after the

insertion of the vane. The initial dial gauge reading was set to the zero and gear handle was turned so that the vane was rotated at the rate of  $0.1^\circ$  per second, this in turn help to get a uniform rate of 12 turns per minute. Vane was rotated completely ten times to disturb the soil. Torque indicator dial gauge reading was noted at half minute interval and rotation of vane was continued until the reading drops appreciable from the maximum.



**Plate 3.1 In-situ measurement of shear strength**

#### **3.1.4 Soil resistance**

A cone penetrometer was used to determine the degree of soil compaction resulting from the application of different tillage operations. The cone penetrometer consisted of force and depth measuring components and a conical tip for penetration into the soil. The force applied is directly read a dial gauge fitted at the top of the instrument. The depth measurement is preceded by the relative movement of the penetration rod and penetrometer tip as the tip is forced into the soil. The experiment was repeated 3 to 4 times at a location, 50 to 60 cm apart to prevent error readings because of soil disturbance. The calibration chart was used to get the penetration resistance of the soil corresponding to the dial gauge reading.

$$\text{Resistance} = \frac{\text{PF}}{\text{BA}} \quad \dots 3.5$$

Where,

PF = penetration force, N

BA = soil depth, cm

Penetration force (PF) = PR x 0.0098

PR = mean dial gauge reading, N



**Plate 3.2 In-situ measurement of soil resistance**

### **3.15 Chemical properties of the Pokkali soil**

The chemical properties of Pokkali soil were studied. The major soil properties, *viz*, pH, Electrical conductivity and organic matter were determined in the present study. Soil samples from different locations of the Pokkali fields were collected to determine the above mentioned properties of the soil. The tests were conducted in the Soil and Water Laboratory at RRS, Vyttila and the available nutrients namely P, K, Ca, S, Fe, B, Al and Na.

### 3.2 STUDY OF KAU POKKALI PADDY HARVESTER

A power operated floating harvester "KAU Pokkali paddy harvester" with provisions for harvesting and conveying the ear heads of water submerged paddy stalks was developed and field tested.

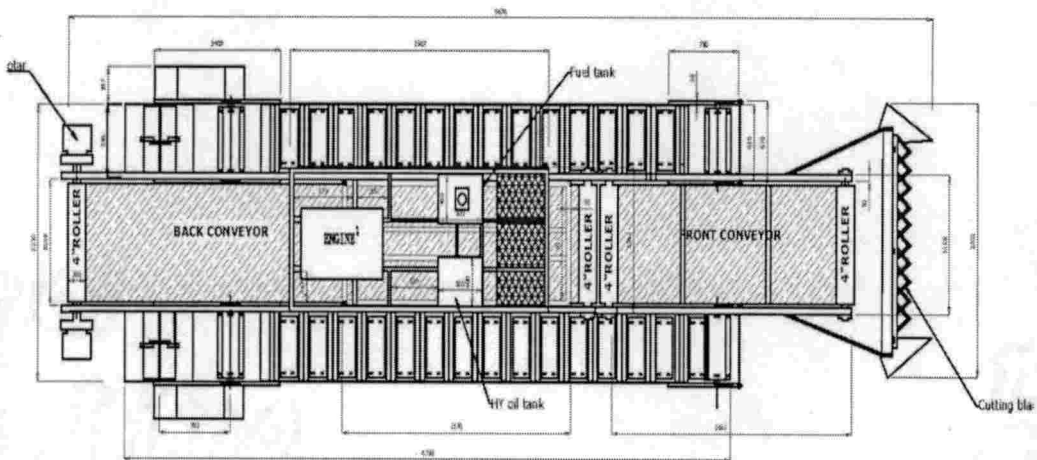

(a) Top view

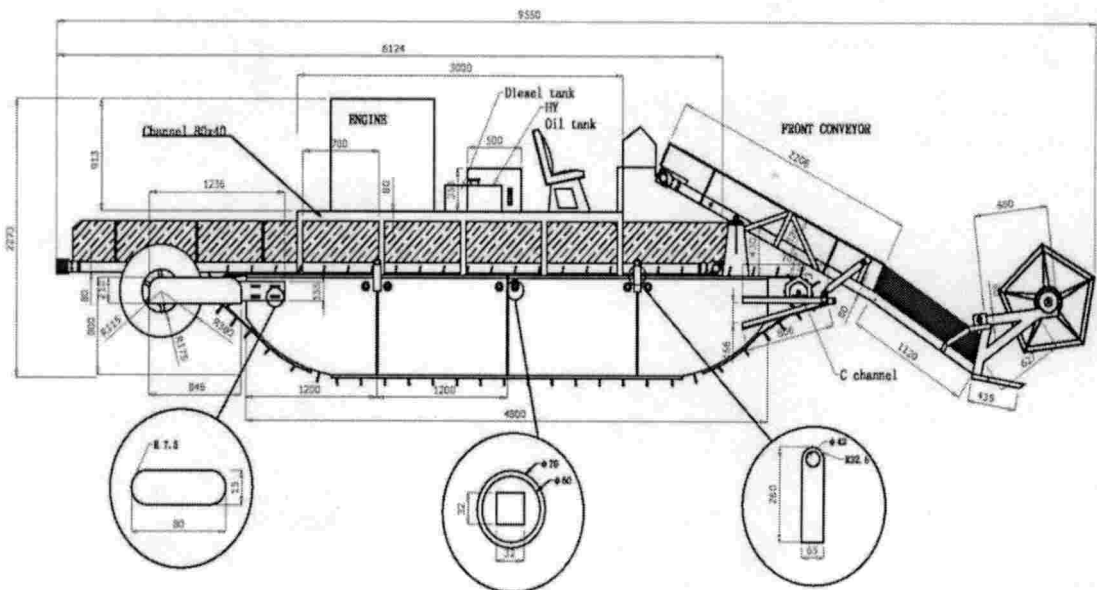

(b) Side view

Fig. 3.1 Orthographic view of KAU Pokkali paddy harvester

Figures 3.1 (a) and (b) refer to the plan and side view of the KAU Pokkali paddy harvester. It consisted of power and control unit, hydraulic system, floating craft with traction device and paddle wheel, cutter bar with reel assembly and belt conveyors. A suitable prime mover of 45.0 hp diesel engine was coupled to the hydraulic pump through a shaft. The hydraulic system comprises of a hydraulic pump, motors and control valve with levers. The hydraulic system actuates separate hydraulic motors, which in turn operate all the required moving parts of the harvester. Separate hydraulic motors are provided for cutter bar, front conveyor, back conveyor, right and left hand floating crafts with paddle wheels respectively. The cutter bar was fitted at the front end of the harvester by a swinging type frame. Thus, swinging cutter bar was able to move up or down, and was operated at any predetermined height of cut. The cutter bar was also attached with a reel by means of chain drive. As and when the direction control lever was operated, the hydraulic motors operate the cutter bar and reel simultaneously. The reel gathers the submerged paddy crop and directs it to the cutter bar, where the crop was being cut by properly positioned swinging front end frame. At the same time, by operating the control lever for the operation of front conveyor, the cut crop from the cutter bar get transferred to the moving front conveyor, from which, was transferred to the back conveyor and finally to the discharge end of the harvester. Thus the cutter bar, reel, the front and back conveyors are working simultaneously. Its propulsion is accomplished by means of either a paddle wheel or floating crafts fitted with endless tracks, when working in water or muddy soil.



**Plate 3.3 Working of KAU Pokkali paddy harvester in fields**

### 3.3 DESIGN ANALYSIS OF EXISTING POKKALI PADDY HARVESTER

The operation of cutting panicle of a crop with part of the plant leaving the undesired portion in the soil is known as harvesting. A paddy harvester is a machine designed for harvesting and collecting of paddy grain and straw while moving through standing crop. But the Pokkali paddy harvester is an amphibian harvester where it has to traverse in water and land or both along with the harvesting operation. Hence the major functions of a Pokkali paddy harvester include floating in water, moving in padded soil, cutting and conveying the paddy crop. The design analysis of the harvester is hence sequentially carried out as design of float barge, harvesting unit and hydraulic system.

#### 3.3.1 Design analysis of floating barge

Floating barge is an air filled structure providing buoyancy. The floats contain a lot of reserve buoyancy and allow designers to carry loads. Floating body is partially immersed in a fluid that experiences an upward force (buoyancy) equal to the weight of the fluid displaced. The float was constructed with MS sheet metal (Gauge-12) of thickness 2.0 mm. Two floats each having dimensions of 4.8 x 0.6 x 0.8 m were fabricated and joined together by means of a chassis. The slope at the front ends of the floats was given 34° to facilitate easy movement of the track belt. The floats are provided at the used in both right and left sides of Pokkali paddy harvester, as shown in Fig. 3.2.

In addition to the two floats, a separate air chamber was also provided in between the two floats. If the chamber be partially immersed in a fluid, experiences an upward force (buoyancy) equal to the weight of the fluid displaced. The chamber was constructed with MS sheet metal (Gauge-12) of thickness 2 mm and of size 4.86 x 1.01 x 0.5 m (Fig. 3.3).

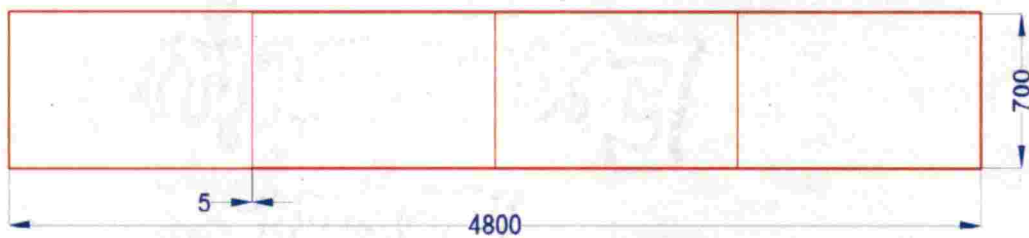

**Top view**

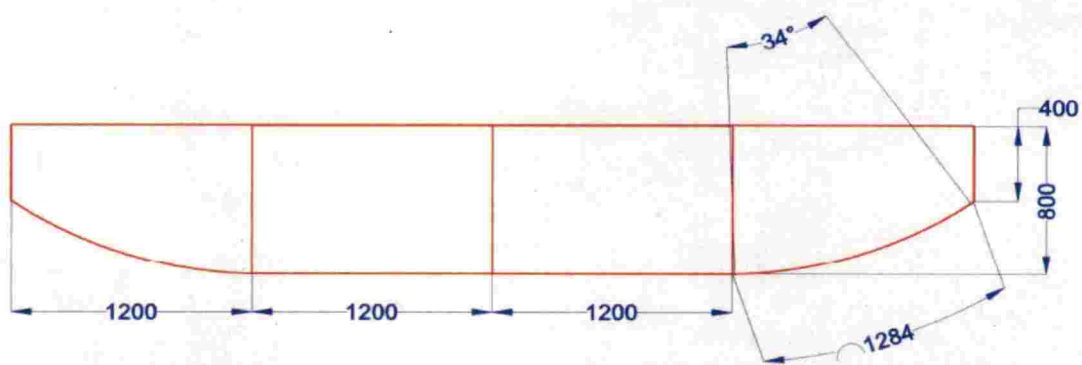

All the dimensions in mm

**Side view**

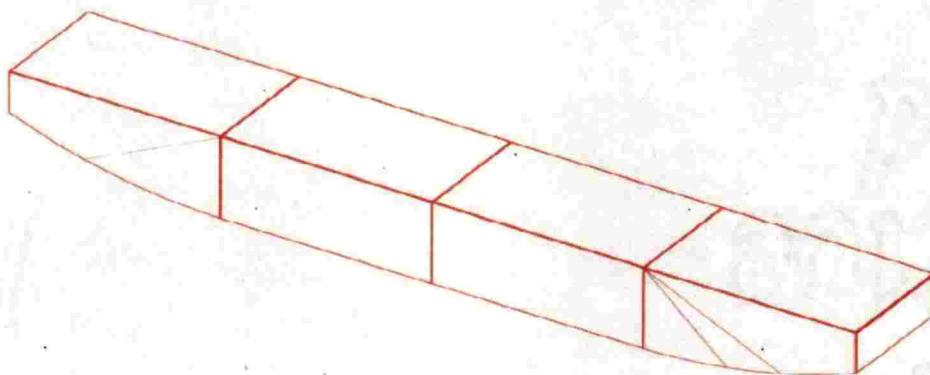

**Isometric view**

**Fig. 3.2 Floating barge of the existing prototype**



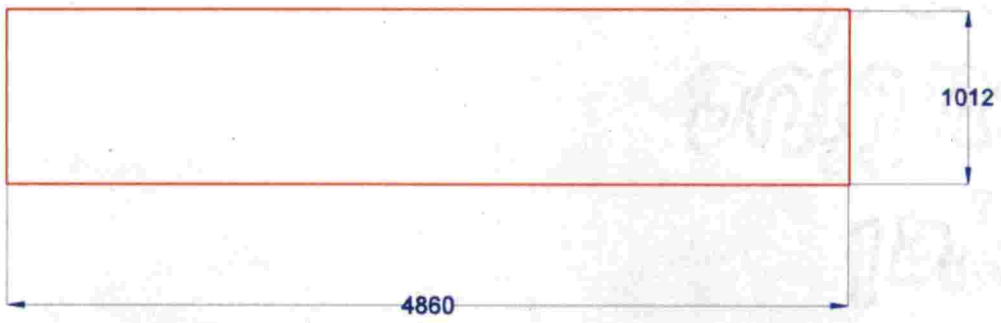

**Top view**

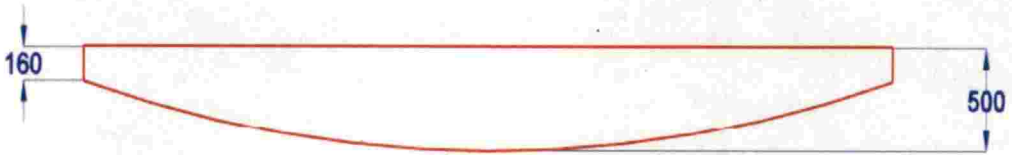

All the dimensions in mm

**Side view**

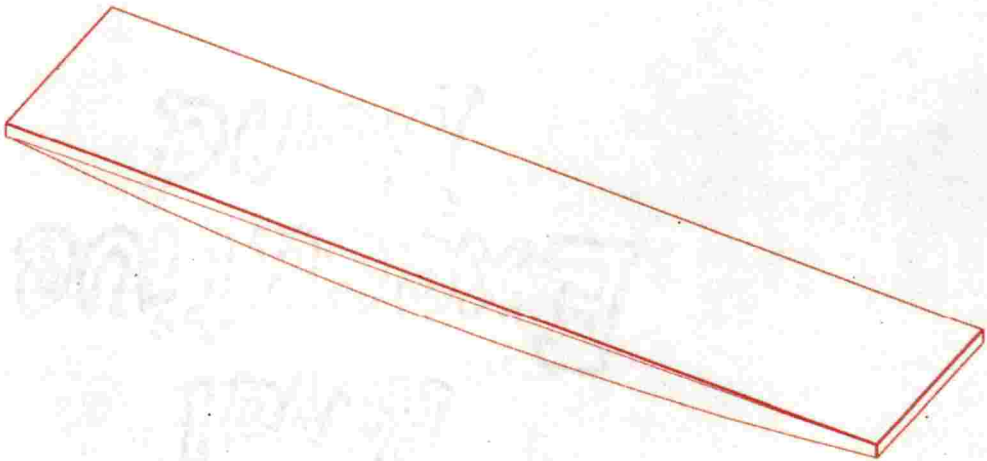

**Isometric view**

**Fig. 3.3 Air chamber of the existing prototype**

### 3.3.1.2 Traction belt

Tractive force is the ability of a vehicle tractive element to generate sufficient forces to overcome the soil resistance. Traction belts were made of polypropylene material having a thickness of 10 mm and size 12 x 0.65 m was provided in order to generate enough traction. Grousers (52 no's) with ledger plates (53 no's) (Fig.3.4) were revetted equidistantly on it. Each grouser was made of marine aluminium at a size of 45.0 x 9.0 x 0.5 cm. (Fig. 3.5).

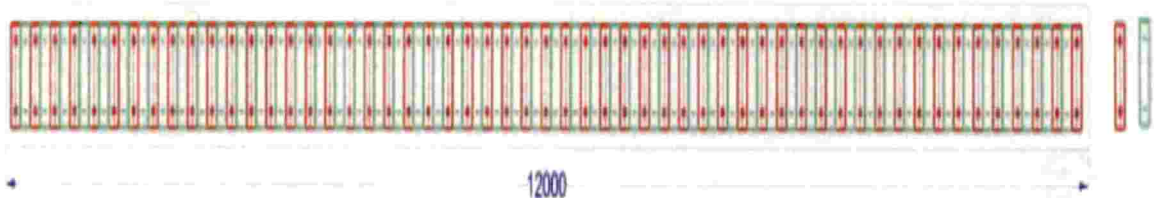

(a) Top view



All the dimensions in mm

(b) Side view

**Fig. 3.4 Traction belt of the existing prototype**

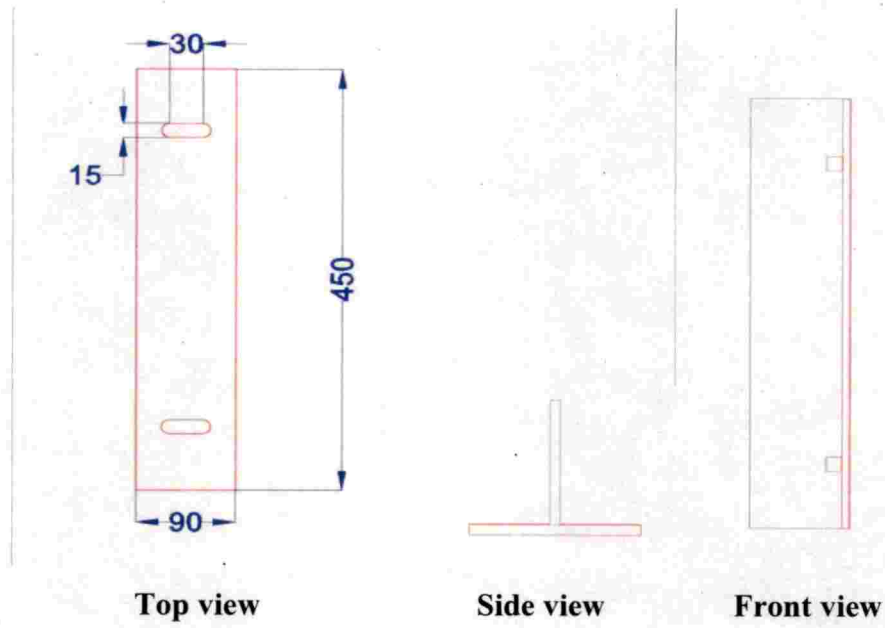

All the dimensions in mm

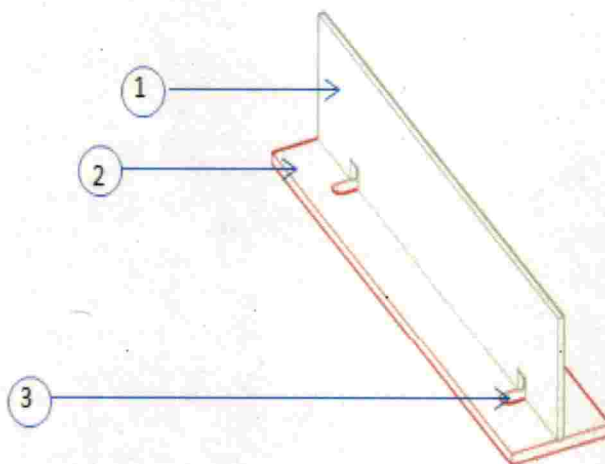

SLNo	Description
1	Flange
2	Base plate
3	Rivets

**Isometric view**

**Fig. 3.5 Grouser (cleat) of the existing prototype**

### 3.3.1.3 Paddle

Paddle is a mechanical device for propelling a floating machine attached to the rear side. A revolving shaft attached with eight broad and angled blades was provided. It was connected to a hydraulic motor (MAT 500SH) through chain drive. The size of the paddle was 0.4 x 0.75 m (Fig. 3.6).

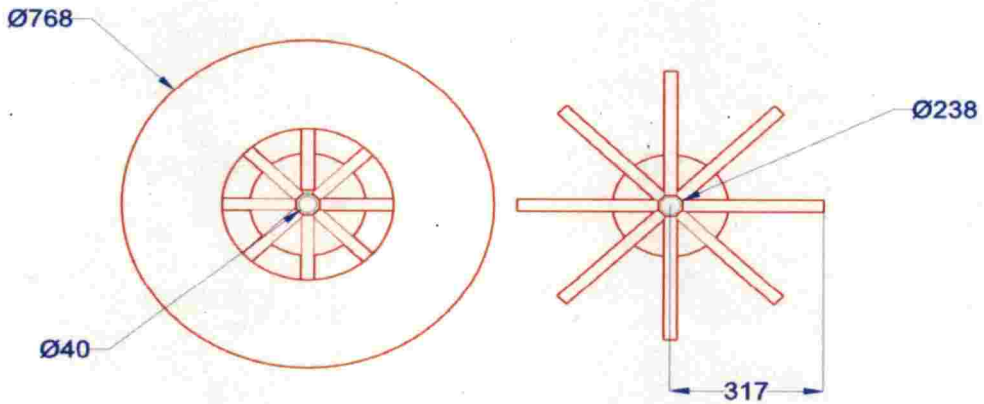

Side view

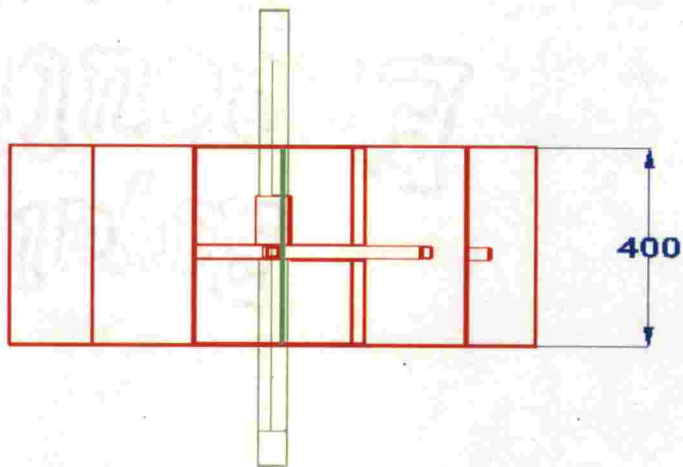

All the dimensions in mm

Top view

Fig. 3.6(a) Orthographic views of the paddle

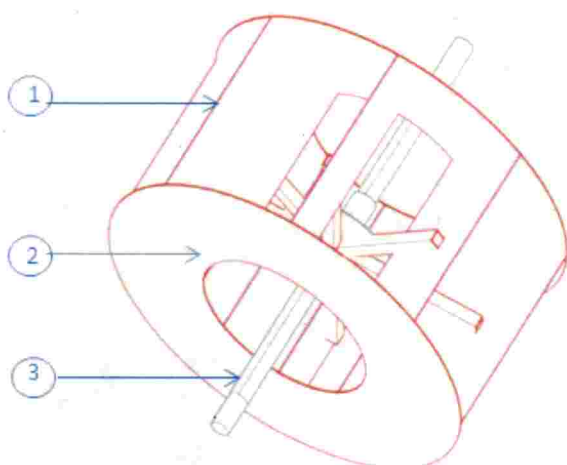

SL.No	Description
1	Angle blade
2	Casing
3	Shaft

**Isometric view**

**Fig. 3.6 Paddle of the existing prototype**

### 3.3.2 Design analysis of hydraulic system

Hydraulic system is a transmission system that uses pressurized hydraulic fluid to power hydraulic machines. Hydraulic drive system consisted of a hydraulic pump, pressure gauge, valves, filters, piping etc. to guide and control the system and actuators viz. a hydraulic motor or hydraulic cylinder to drive the harvester. Engine drives the hydraulic pump which in turn pressurises hydraulic oil and directs it to the direction control valves. The direction control valves were operated by six control levers fitted at the control panel in front of the operator seat. The pressurised fluid was to actuate the members viz., cutter bar with reel, front and centre conveyors, right and left hand floats with paddle wheel (propeller) and two hydraulic cylinders for operating up and down motion of the cutter bar, reel assembly and front conveyor. It was independently connected by separate motors and cylinders through separate levers (Fig.3.7).

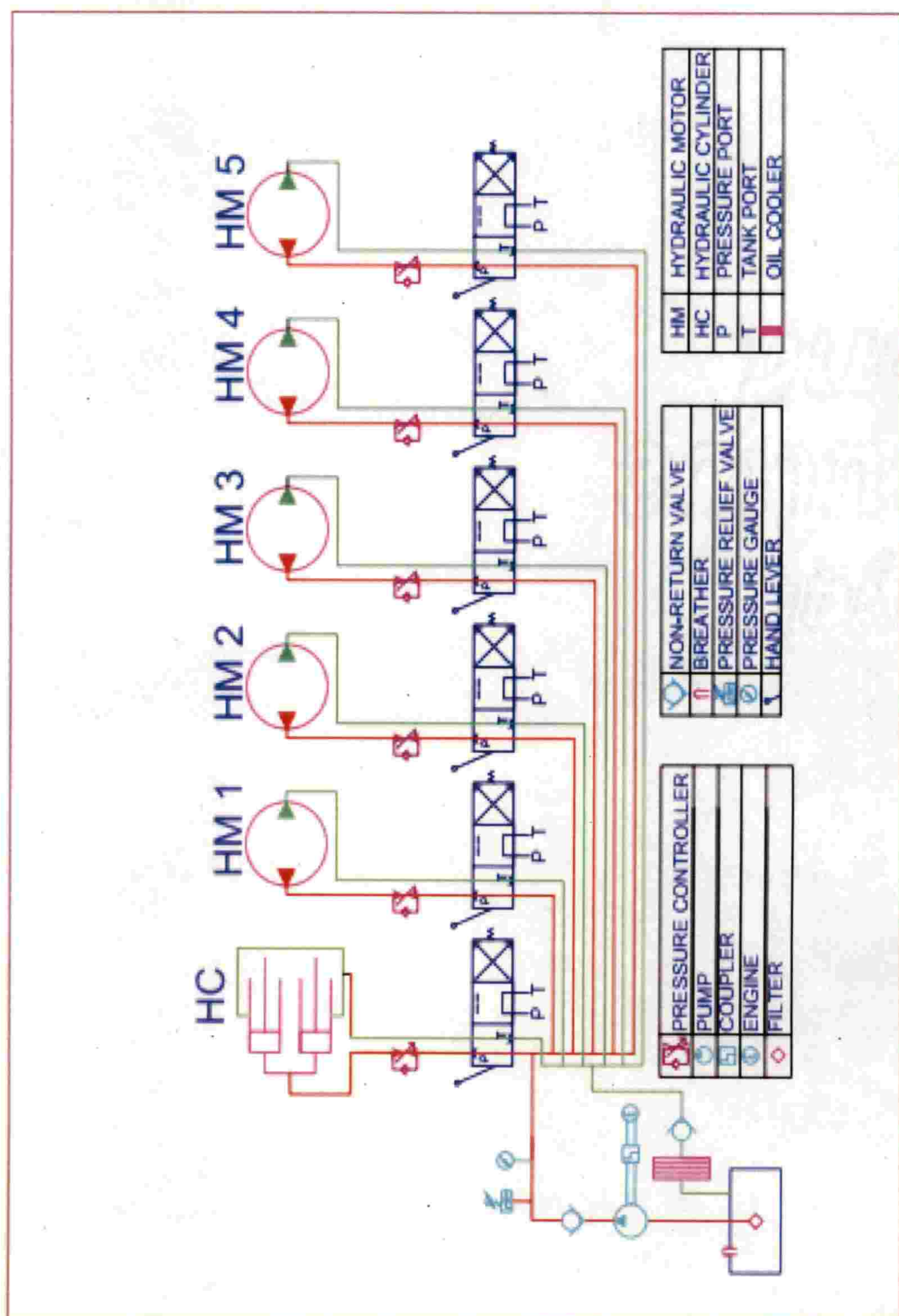

Fig. 3.7 Hydraulic circuit of the KAU Pokkali paddy harvester

### 3.3.2.1 Hydraulic tank

The capacity to meet the hydraulic oil requirement for operating Pokkali paddy harvester was 61 litres per minute. In order to ensure the required supply of hydraulic oil 2.5 times more than required hydraulic pump capacity was taken into consideration and hence a tank of capacity 150 litres was selected.

### 3.3.2.2 Hydraulic pump

The capacity to meet the hydraulic oil pressure for operating Pokkali paddy harvester was taken into consideration for the selection of hydraulic pump. A double acting pump having a capacity of 61 litres per minute was hence selected for its working. Seamless tubes with high wall thickness, higher tensile strength, better bending quality, etc. are some of the specific properties which make such tubes most suitable for use in many high pressure hydraulic systems.

### 3.3.2.3 Hydraulic cylinders

Hydraulic cylinder used for the conveyor system was a double acting hydraulic cylinder which provided linear displacement. The function of this hydraulic cylinder was to convert hydraulic power into linear mechanical force or motion. The cylinder was fixed in between the float frame and the front conveyor. The hydraulic cylinder of diameter of 50 mm, stroke of 30 cm with a piston of 40 mm was used. Inlet and outlet diameters of the ports were of 22 mm as shown in Fig.3.8. The hydraulic fluid enters to the cylinder through the inlet and outlet ports of the cylinder. When fluid flow was allowed to the back end port, the forward stroke takes place then the fluid from the rod end port returns to the reservoir. During this period the conveyor experienced an upward motion. When fluid flow was allowed to the rod end port, reverses the stroke and hence conveyor moves in downward direction. Two hydraulic cylinders were used for the up and down motion for the front conveyor along with the cutter bar and reel assembly.

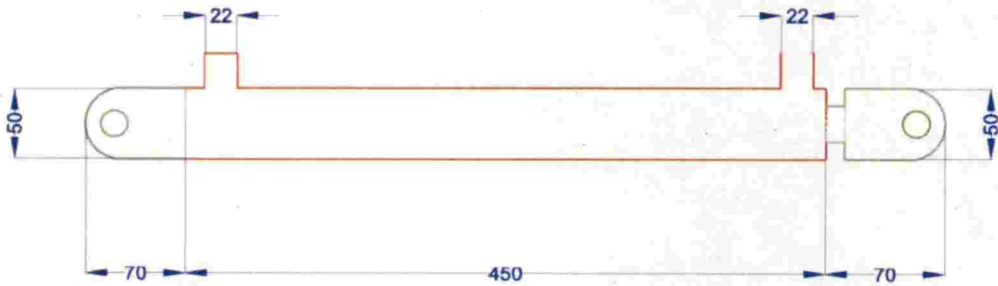

All the dimensions in mm

**Fig. 3.8 Hydraulic cylinder**

Pressure required for the working of the hydraulic system is calculated using the equation

$$(P) = \frac{F}{A} \quad \dots 3.6$$

Where,

P = pressure,  $\text{kg cm}^{-2}$

F = weight to be lifted, kg

A = Area of the cylinder bore,  $\text{cm}^2$

### 3.3.2.4 Hydraulic motors

Gerotor type motors were used in the harvester for actuating all the attached units of the harvester. Pressurized fluid was guided into the assembly using an axially placed plate-type distributor valve. Typically, the gerotor motors are having low-to-medium speed and medium-to-high torque. The five different hydraulic motors were used in the study viz. MR50 motor for cutter bar, MAH-400CB motor for both front and centre conveyors and MAT-500SH for both right and left side floats.





**Plate 3.4 Gerotor motor**

### **3.3.2.5 Direction control valves**

These valves are also called as on-off valves as they allow the fluid flow only in one direction (Jagadeesha, 2012). A directional control valve (Plate 3.5) is a device which controls the flow of fluid from the hydraulic pump to hydraulic cylinders. These valves are the primary devices used to sequence the motion of the harvester. The valve is generally specified by the number and positions of the ports in the system. For operating the floats, two-in-one directional control valve is required with 4 ports was used. The control valve consisted of two levers of which, lever-1 operates hydraulic motor of the left side float and lever-2 operates the hydraulic motor of the right side float. It is having an inlet port and outlet port. The hydraulic fluid from the pump passes through a main line and enters in to the inlet port of the control valve. When the control lever was pushed to forward the fluid will pass through outlet with high pressure, which caused the rotation of the gears in the hydraulic motor. It will facilitate the forward and backward movement of float. If lever-1 pushes forward, the left-float operates forward movement and lever push backward, it backward and place in neutral to stop the movement. If lever-2 push forward, the right hand float move forward and lever push backward, it move backward and place neutral to stop the movement.

For operating the front conveyor, one-in-one directional control valve with two ports was used. The control valve consists of one lever; lever-3 operates hydraulic motor of the front conveyor. If lever-3 pushes forward the front

conveyor operate forward movement and lever push backward, it operates backward movement and place in neutral to stop the movement. For operating the centre conveyor, hydraulic cylinders and cutter bar with reel, three-in-one directional control valve with 6 ports was used. The control valve consists of three levers; lever-4 operates hydraulic cylinders. If lever-4 push forward the hydraulic cylinders, piston rod extension and lift the upward front frame along with conveyor, cutter bar and reel assembly. If lever push backward the hydraulic cylinders, piston rod compressed and downward upward front frame along with conveyor, cutter bar and reel assembly. Lever-5 operates hydraulic motor for the centre conveyor. If lever-5 push forward, the back conveyor move forward and lever push backward, it move backward and place neutral to stop the movement. Lever-6 operates hydraulic motor of the cutter bar. If lever-6 push forward it causes reciprocating movement and lever push backward, it move backward and place neutral to stop the movement.



Lever 1 Lever 2



Lever 3

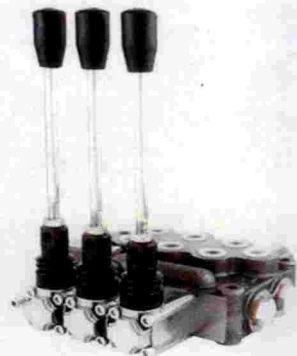

Lever 4 Lever 5 Lever 6

**Plate 3.5 Direction control valves**

### 3.3.3 Design analysis of harvesting unit

The operation of cutting panicle of a crop with part of the plant leaving the undesired portion in the soil is known as harvesting. Harvesting unit of the Pokkali paddy harvester consists of a reel, cutter bar and conveyor. Reel delivers the stalks to the cutting mechanism, the cutter bar cuts crop and conveys through front conveyor and transferred to in the central conveyor. The whole harvesting

assembly was procured directly from the manufacturer and assembled with the floating barge. The design analysis of the complete unit was separately carried out for reel, cutter bar and conveyor units.

### **3.3.3.1 Reel**

Reel delivers the stalks to the cutting mechanism. It holds the crop upright during cutting and delivers the cut stalks to the front conveyor. A fixed bat type reel (Fig. 3.9) assembly was used. It has a pentagonal frame fitted with five bats of length 182.5 cm fixed at a uniform spacing of 52 cm. The diameter of each bat was 5 cm. A total of eleven fingers, each would and firmly fixed at uniform interval of 15 cm. The reel assembly can be operated by a hydraulic motor (MR50) through chain drive. The design of the reel can be made according to the reel position with respect to cutter bar, reel speed with respect to forward speed, delivering the stalk to the cutting mechanism with minimum losses, holding the stalk upright while cutting and delivering the stalk to the conveyor. Also, the absolute velocity of the reel is greater than the forward speed of the harvester.

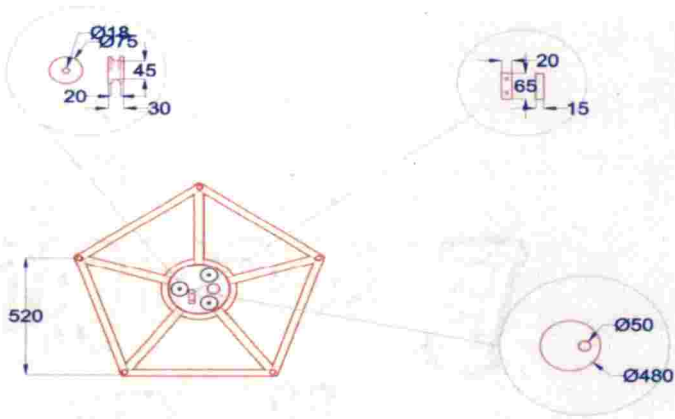

Side view

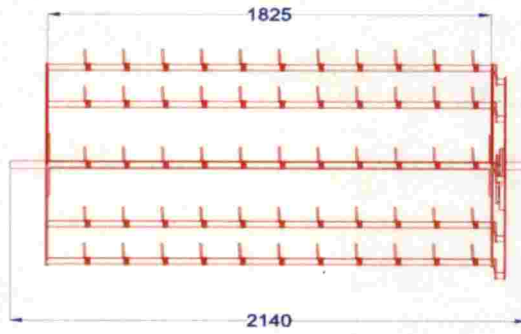

All the dimensions in mm

Front view

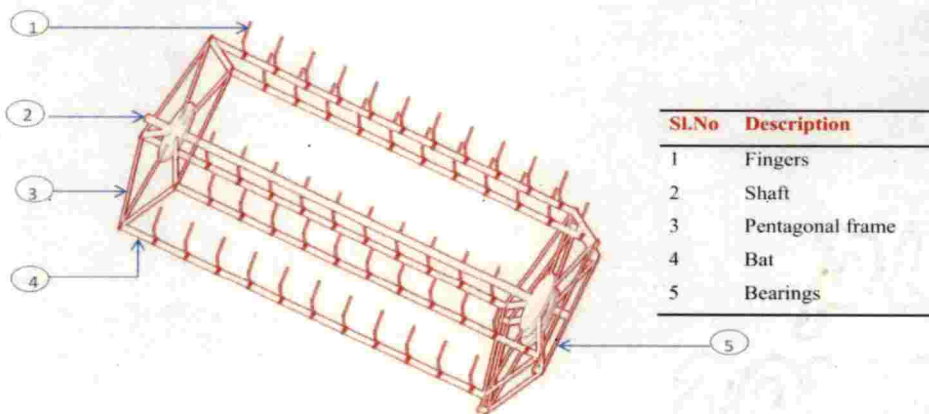

Isometric view

Fig. 3.9 Reel assembly of the existing prototype

The reel index was calculated based on the standard design procedures:

Reel index or velocity ratio ( $\lambda_i$ ) for reels is given by (Kanafojski and Karwowski, 1976):

$$\lambda_i = \frac{u_t}{v_m} \quad \dots 3.7$$

Where,

$u_t$  = tangential velocity of tip of the bats,  $m s^{-1}$

$v_m$  = forward velocity,  $m s^{-1}$

$$\text{Tangential velocity of tip of the bats, } u_t = \omega_r R_r \quad \dots 3.8$$

Where,

$\omega_r$  = angular velocity of reel,  $rad s^{-1}$

$R_r$  = radius of reel, mm

$$\omega_r = 2\pi N$$

$$= 2 \times 3.142 \times 16$$

$$= 100.54 \text{ rad min}^{-1}$$

$$= \frac{100.54}{60}$$

$$= 1.675 \text{ rad s}^{-1}$$

$$u_t = \omega_r R_r$$

$$= 1.675 \times 0.42$$

$$= 0.7035 \text{ m s}^{-1}$$

$$\begin{aligned} \text{Reel index } (\lambda_i) &= \frac{u_t}{v_m} \\ &= \frac{0.7035}{0.416} \\ &= 1.7 \end{aligned}$$

$$\text{Size (pitch) of reel } (P_r) = \frac{S_m}{Z}$$

Where,

$Z$  = number of bats on reel (5 Nos.)

$S_m$  = distance traversed by the machine during one revolution of the reel, mm

$$P_r = \frac{260}{5}$$

$$= 52 \text{ cm}$$

### 3.3.3.2 Cutter bar

Cutter bar is a major part of a harvester to cut the stalk. It was operated by a hydraulic motor (MR50) through a crank pitman. A reciprocating type cutter bar of 2.1 m length having 27 knife sections, each having a stroke of 76.2 mm was provided. A standard size twin guard was also provided on either ends of the cutter bar. These guards were provided to gather the crop and fed it to the cutter bar. In order to avoid slipping off the stalks, serrated knife sections were attached with the cutter bar. The pitch of serrated knife sections selected as two times smaller than the diameter of paddy stalk. Accordingly the pitch provided was 1.2 mm. Clearance between knives and ledger plates were maintained at 0.3 mm. The velocity of knife section was hence  $0.833 \text{ m s}^{-1}$  at a forward speed of  $3 \text{ km hr}^{-1}$ . Design analysis of the cutter bar was carried out for finding the optimum speed and number of knife sections based on the standard procedures.

The cutting of stalk is greatly affected by knife speed. The velocity of knife section is expressed as:

$$V_k = R \times V_m \quad \dots 3.9$$

Where,

$V_k$  = Average knife velocity,  $\text{m s}^{-1}$

$V_m$  = Forward speed of harvester,  $\text{m s}^{-1}$

R = Velocity ratio

According to Klenin (1985) the ( $\alpha$ ) angle between cutting edge and axis of knife section was  $31^\circ$  and the velocity assumed was  $1.5 \text{ m s}^{-1}$ . The value of R falls between 1.3 to 1.4 with available cutter knife.

Taking  $R = 1.3$  and  $V_m = 0.416 \text{ m s}^{-1}$  and putting values in above equation (3.9)

$$\begin{aligned} V_k &= 1.3 \times 0.416 \\ &= 0.536 \text{ m s}^{-1} \end{aligned}$$

$$\text{Number of knife sections} = \frac{L_c}{\text{size of knife section}} \quad \dots \text{ 3.10}$$

Where,

$L_c$  = Length of the cutter bar, cm

$$\begin{aligned} \text{No. of knife sections} &= \frac{210}{7.62} \\ &= 27.55 \text{ (say, the cutter bar has 27 knife sections)} \end{aligned}$$

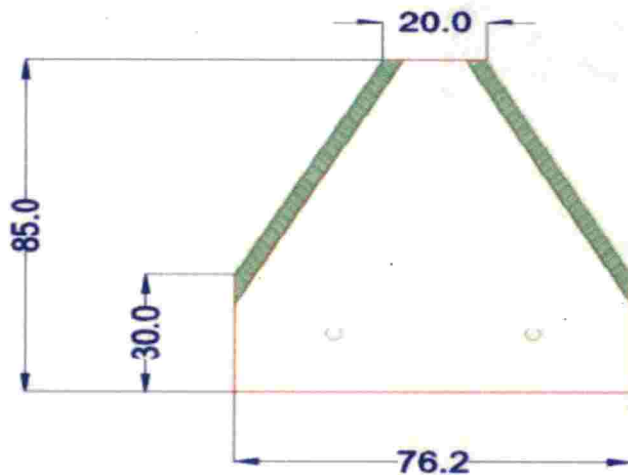

All dimensions in mm

**Fig. 3.10 Knife section of the cutter bar of the existing prototype**

### 3.3.3.3 Front conveyor

The crop cut by the cutter bar was conveyed to the conveyor (Fig.3.11) for easy collection. It was made of 3.0 mm polypropylene sheet with equidistantly spaced rubber bars. The conveyor was to convey the bunch of cut crop continuously without blockage. It was operated by a hydraulic motor MAH-400CB through the driving roller. This roller actuated the motion of the conveyor and the driven roller was provided at the tail end, trailed the conveyor forward and ensured continuous movement. The length of the conveyor belt was hence 3.0 x 1.0 m. The conveyor belt has to be wrapped over two rollers of 100 mm diameter and fixed separately on plummer blocks to stretch it firmly.

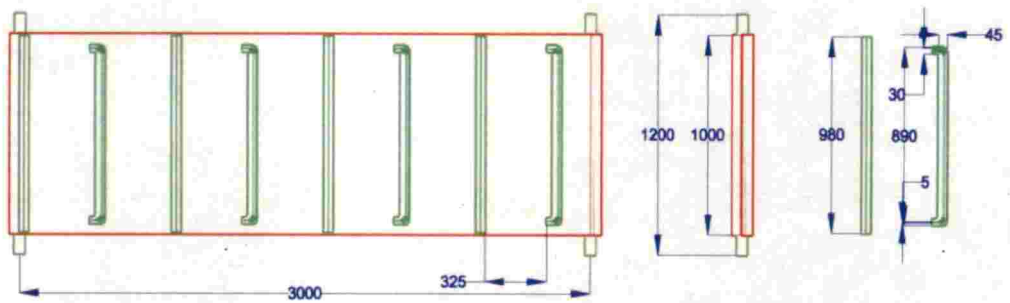

All the dimensions in mm

(a) Top view

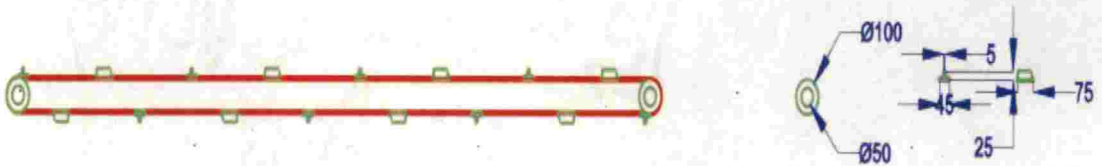

All the dimensions in mm

(b) Side view

**Fig. 3.11 Front conveyor of the existing prototype**



Design analysis of the front conveyor was carried out for finding the speed of conveyor belt, length of conveyor belt, pitch, clearance and height of lugs based on standard procedures.

Speed of conveyor belt:

For a lugged belt conveyor the belt speed is given by

$$V_b = \pi \frac{D_p N_p}{60} \quad \dots 3.11$$

Where,

$D_p$  = Diameter of conveyor belt roller, m

$N_p$  = Speed of conveyor belt roller, rpm

$V_b$  = Peripheral speed of flat belt, m s<sup>-1</sup>

$$\begin{aligned} V_b &= 3.142 \frac{0.1 \times 89}{60} \\ &= 0.47 \text{ m s}^{-1} \end{aligned}$$

### Length of conveyor belt:

It was calculated based on length of platform required for supporting the crop

Hence, centre to centre distance (C) between driving and driven roller was provided as 3.0 m.

The length of belt is given by,

$$\begin{aligned} L &= 2C + \pi \frac{(D+d)}{2} + \frac{(D+d)^2}{4C} \quad \dots 3.12 \\ &= 2 \times 3 + 3.142 \frac{(10+10)}{2} + \frac{(10+10)^2}{4 \times 3} \\ &= 6.32 \text{ m} \end{aligned}$$

The length of flat belt required for belt conveyor would be 6.32 m.

Pitch of lugs:

According to Devnani (1985), number of lugs on conveyor belt is

$$N = \frac{L}{P} \quad \dots 3.13$$

Where,

N = Number of lugs on conveyor belt

L = Length of belt, m

P = Pitch of lugs, m

$$N = \frac{6.32}{0.325}$$

$$= 19$$

Lug height and clearance:

The lug height was fixed in such a way that the height of bushes of cut crop that can be conveyed continuously without any blockage. This was only possible when conveyor output per unit time was greater than or equal to output from the cutter bar.

Therefore, output of conveyor  $\geq$  cutter bar output

$$h * w * \rho_2 \geq \rho_1 * w^2 * \frac{V_m}{V_c}$$

$$\text{Take } \frac{\rho_2}{\rho_1} = q = \frac{A_1}{A_2}$$

$$\text{Then, } h \geq \left(\frac{w^2}{q}\right) \times \left(\frac{V_m}{V_c}\right) \quad \dots 3.14$$

Where,

h = Height of lug, cm

$w$  = Cutting width of machine, cm

$V_m$  = Travelling speed of machine,  $m\ s^{-1}$

$V_c$  = Speed of belt conveyor,  $m\ s^{-1}$

$\rho_1$  = Density of plant in field,  $g\ cm^{-3}$

$\rho_2$  = Density of cut crop on the platform,  $g\ cm^{-3}$

$q$  = Gathered crop parameter

$A_1$  = Area of the field selected (say,  $1\ m^2$ )

$A_2$  = Cross-sectional area of plants cut from the selected area of  $1\ m^2$

For all cases we can take  $A_2 = 0.015\ m^2$

$$q = \frac{A_1}{A_2}$$

$$= \frac{1}{0.015} = 66.77$$

Putting values of  $q$  in the eqn. 3.14 we get,

$$h \geq \frac{210}{66.77} \times \frac{0.833}{0.833}$$

$$h = 3.15\ cm$$

Therefore, a clearance of 12-15 mm between conveyor belt and cutter unit was maintained.

### 3.3.4 Centre conveyor

The crop was conveyed from the front conveyor to the centre conveyor (Fig.3.12) for easy collection and storage of the cut crops. It was made of 3.0 mm polypropylene sheet. The conveyor was to convey the bunch of the cut crops. It was operated by a hydraulic motor MAH-400CB through the driving roller. This roller actuated the motion of the conveyor and the driven roller provided at the tail end trailed the conveyor forward and ensured continuous movement. The length

of the conveyor belt was 6.33 x 1.0 m. The conveyor belt may be wrapped over two rollers of 100 mm diameter, which were fixed separately on plummer blocks to stretch firmly.

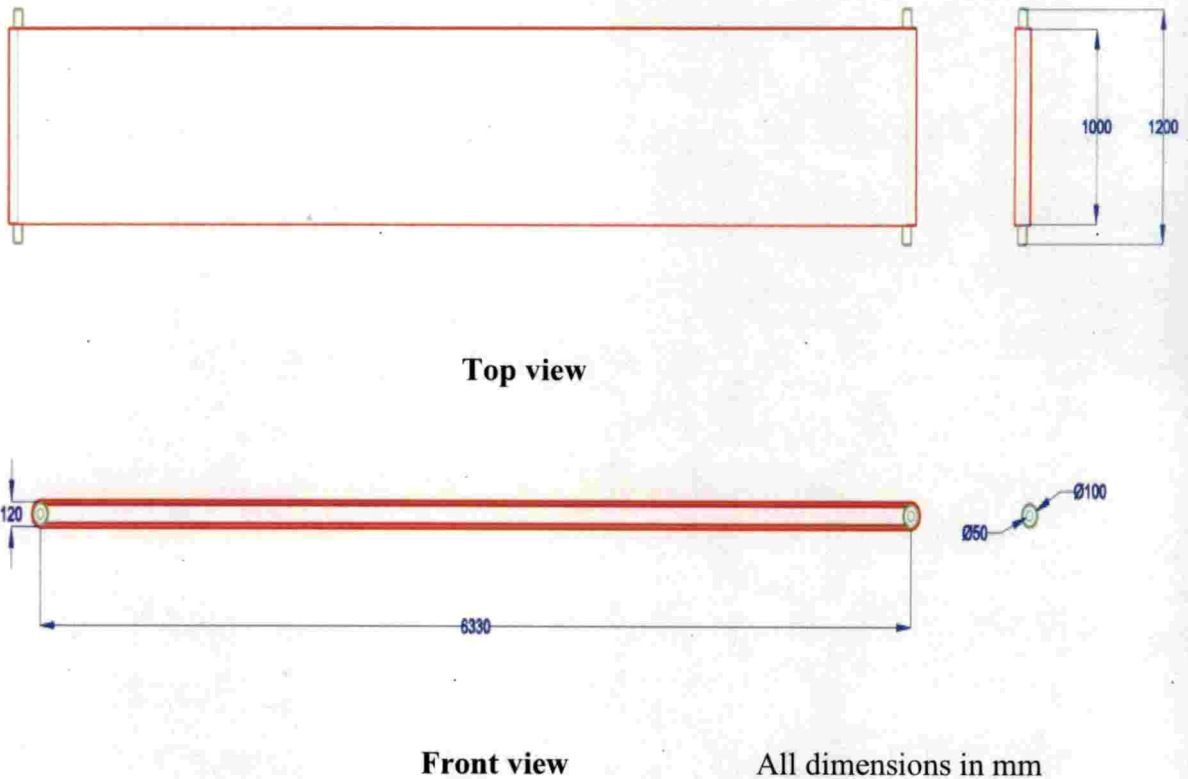

**Fig. 3.12 Centre conveyor of the existing prototype**

Design analysis of the centre conveyor was also carried out for finding the length of conveyor belt based on the standard procedures:

Length of conveyor belt:

It was calculated based on length of horizontal platform required for supporting the crop.

Length of horizontal platform = 6.33 m

Hence, centre to centre distance (C) between driving and driven roller was provided as 6.33m.

The length of belt is given by

$$L = 2C + \pi \frac{(D+d)}{2} + \frac{(D+d)^2}{4C} \quad \dots 3.15$$

$$= 2 \times 6.33 + 3.142 \frac{(0.1+0.1)}{2} + \frac{(0.1+0.1)^2}{4 \times 6.33}$$

$$= 12.98 \text{ m}$$

Hence, the length of flat belt provided for centre conveyor was 1298 cm.

### 3.3.4 Prime mover

The capacity to meet the power requirement for harvesting was taken into consideration for the selection of the prime mover. The total weight of the KAU Pokkali paddy harvester comes around 3000 kg. In order to operate cutter bar, reel assembly, front conveyor, centre conveyor and float with hydraulic motors and then to lift the front conveyor with hydraulic cylinders sufficient power shall be ensured. Hence, 45 hp diesel engine was selected as the prime mover.

### 3.3.5 Stability analysis

The float design and its stability analysis were carried out at Department of Ship Technology, CUSAT, Kochi. Buoyancy is an upward force exerted by a fluid that opposes the weight of an immersed object. When the floating barge is at certain weight of harvester, it sinks to a certain depth. This allows adequate freeboard to prevent any water from getting on board. A floating object is stable if it tends to restore itself to an equilibrium position after a small displacement. The upward buoyancy force on an object acts through the centre of buoyancy, being the centroid of the displaced volume of fluid. The weight force on the object acts through its centre of gravity.

One of the key design criteria for the scale down prototype is the stability requirement of the floating structure. The barge has to be stable in water and unaffected by waves, wind, tides and the mass of the cut crops.

### a) Transverse Stability

Transverse centre of buoyancy is the point through which the force of buoyancy on the supporting vessel acts vertically upwards. Transverse centre of gravity is the point through which all of the weight of the vessel including deadweight items acts vertically downwards. When the machine is upright, both the centre of buoyancy and the centre of gravity are on the centre line of the vessel.

i.e.  $T_{CG} = 0$

$$T_{CG} = \frac{\sum T_{mt}}{\sum W_t} = 0 \quad \dots 3.16$$

Where,

$T_{CG}$  = transverse centre of gravity, m

$W_t$  = weight of the machine, tonnes

$T_{mt}$  = transverse weight, tonnes

The transverse centre gravity for Pokkali paddy harvester is zero. Hence the harvester is stable to floating on the water.

### b) Longitudinal Stability

If longitudinal centre of gravity and longitudinal centre of buoyancy are in the same vertical line and if there is no trimming moment on the machine,

$$L_{CG} = \frac{\sum L_{mt}}{\sum W_t} \text{ meters.} \quad \dots 3.17$$

Where,

$L_{CG}$  = longitudinal centre of gravity, m

$W_t$  = weight of the machines, tonnes

$L_{mt}$  = longitudinal weight, tonnes

Pokkali paddy harvester is stable to float, the longitudinal centre of gravity lies near to the centre and adjacent to the front and rear side of the harvester, it become a well-balanced machine.

### c) Vertical stability

Let the  $W$  be the weight of the floating body and  $V_o$  be the submerged volume. Then downward weight of the body is balanced by the upward buoyant force ( $B$ ).

$$B = \rho_o V_o g$$

$$V_{CG} = \frac{\sum V_{mt}}{\sum W_t} \text{ meters.} \quad \dots 3.18$$

Where,

$V_{CG}$  = Vertical centre of gravity, m

$W_t$  = weight of the machine, tonnes

$V_{mt}$  = vertical weight, tonnes

### 3.4 DESIGN OF SCALE DOWN POKKALI PADDY HARVESTER

The KAU Pokkali harvester developed was of larger in size and weight; the manoeuvrability becomes a great problem for transportation and operation in small paddy fields. This necessitated in designing a scale down prototype of the harvester to operate in all Pokkali areas with easy transportation and good manoeuvrability features. Also, the study of stability aspects of the harvester considering buoyancy, floatation and traction parameters ensures a proper design for a scale down prototype of the KAU Pokkali paddy harvester. The scale down Pokkali paddy harvester is hence designed for harvesting and collecting of panicle (ear head) of the paddy, while moving through the waist depth water. It is also designed as an amphibian harvester where it can traverse in water and land or both along with the harvesting operation. Hence the major functions of a Pokkali

paddy harvester include floating in water, moving in puddled soil, cutting and conveying the ear head of the paddy crop. The design is hence sequentially carried out as design of floating barge, harvesting unit and hydraulic system.

### **3.4.1 Design of floating barge**

Floating barge is an air filled structure providing buoyancy. The floats contain a lot of reserve buoyancy and allow to carry loads. Floating body is partially immersed in a fluid that experiences an upward force (buoyancy) equal to the weight of the fluid displaced. The float be constructed with MS sheet metal of thickness 2.0 mm as that of the original prototype. But, each float (Fig. 3.13) should have dimensions of 3.0 x 0.45 x 0.6 m only. The side slope has to be made  $34^{\circ}$  to facilitate easy movement of the track belt. The two floats have to be provided on either sides of Pokkali paddy harvester.

In addition to the two floats, a separate air chamber be provided in between the two floats. When the chamber is partially immersed in a fluid, it experiences an upward force (buoyancy) equal to the weight of the fluid displaced. The chamber also be constructed with MS sheet metal (Gauge-12) of thickness 2 mm and of size 3.0 x 0.6 x 0.4 m (Fig. 3.14(a)).



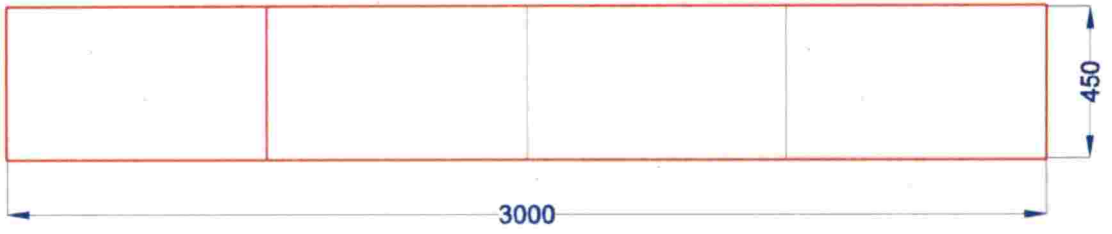

**Top view**

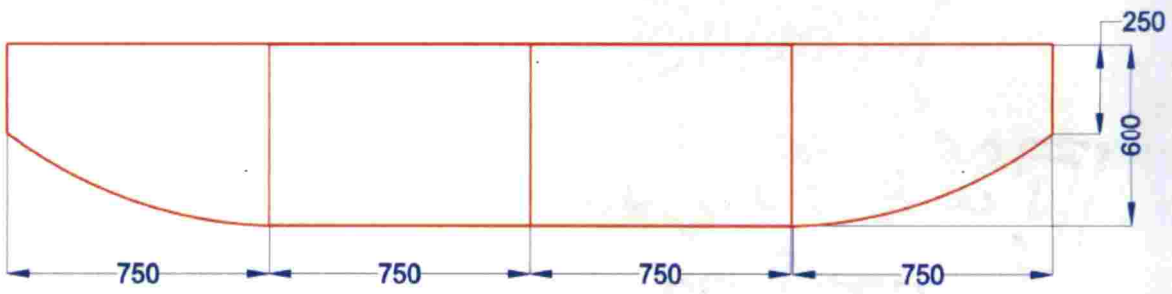

All dimensions in mm

**Side view**

**Fig. 3.13(a) Orthographic views of the floating barge**

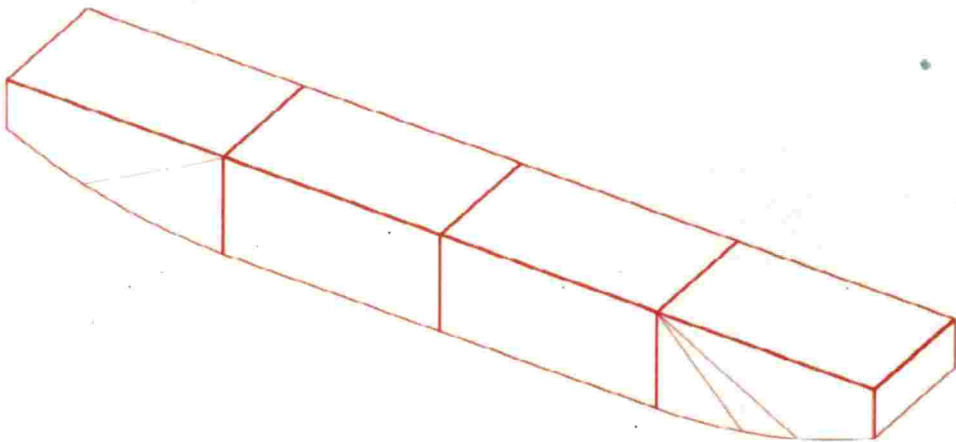

**(b) Isometric view**

**Fig. 3.13 Floating barge of the scale down prototype**

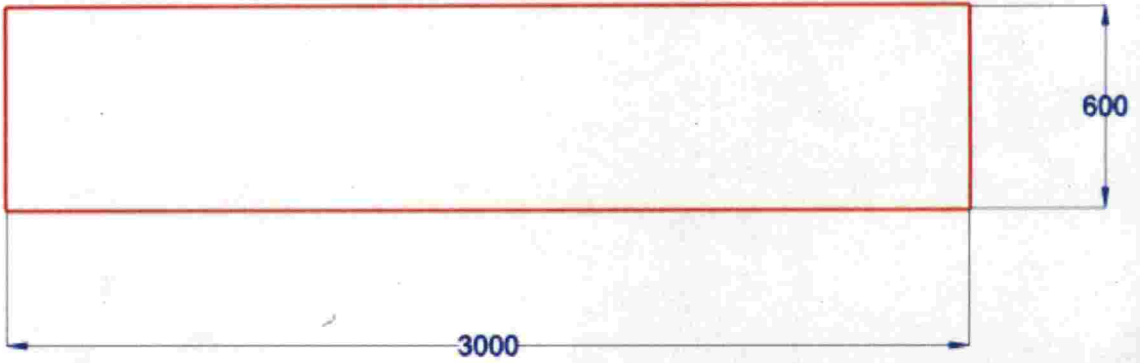

Top view

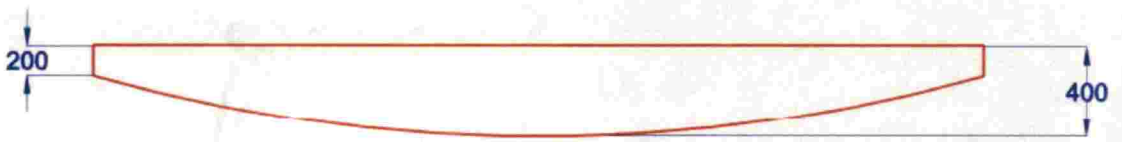

All dimensions in mm

Side view

Fig. 3.14(a) Orthographic views of the air chamber

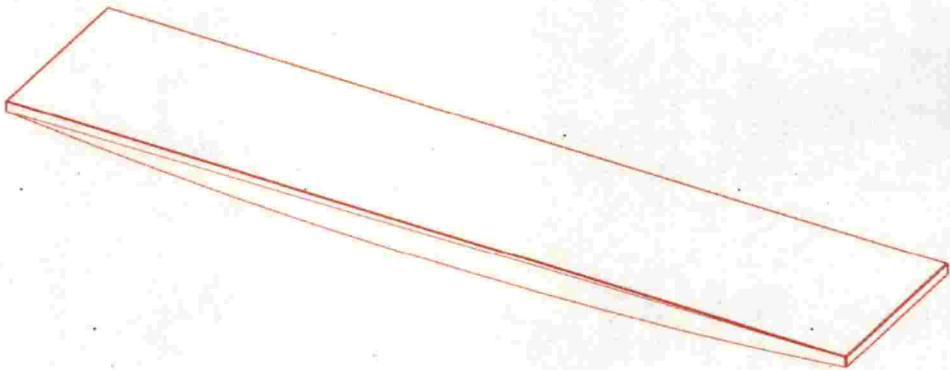

(b) Isometric view

Fig. 3.14 Air chamber of the scale down prototype

### 3.4.1.2 Traction belt

Tractive force is the ability of a vehicle tractive element to generate sufficient forces to overcome the soil resistance. Tractive belts made of Polypropylene having a thickness of 10 mm and size 6.60 x 0.45 m is provided to generate enough traction. Grousers (30 no's) with ledger plates (30 no's) (Fig.3.15) have to be riveted equidistantly on it. Each grouser has a 30 x 9 x 0.5 cm, be made of marine aluminium (Fig. 3.16).

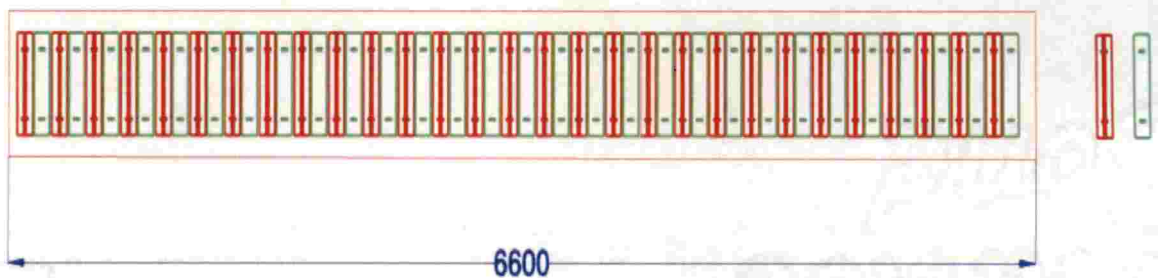

All dimensions in mm

(a) Top view



(b) Side view

**Fig. 3.15 Traction belt of the scale down prototype**

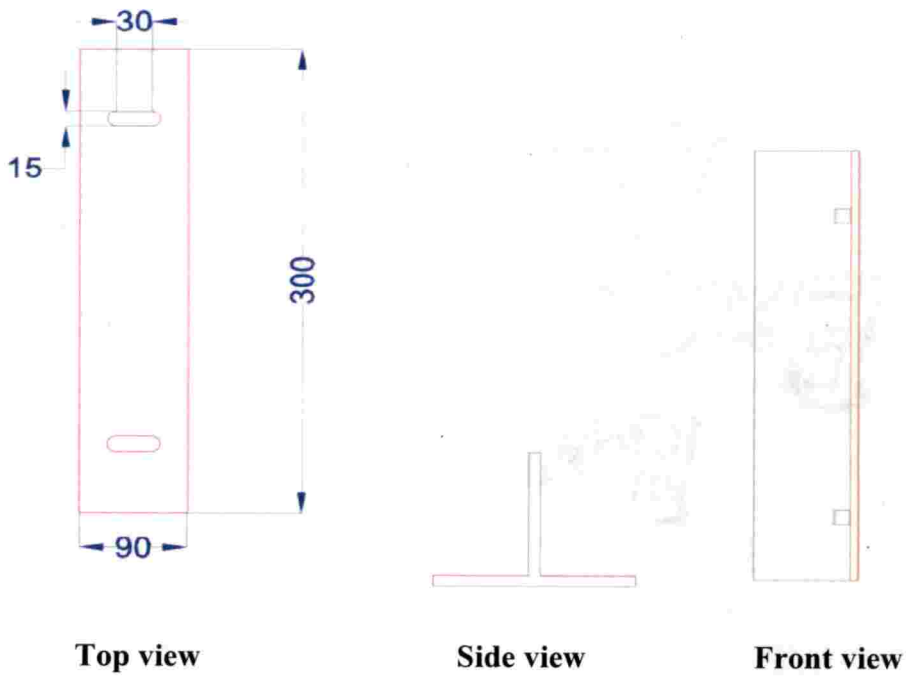

Top view

Side view

Front view

All dimensions in mm

Fig. 3.16(a) Orthographic views of the grouser

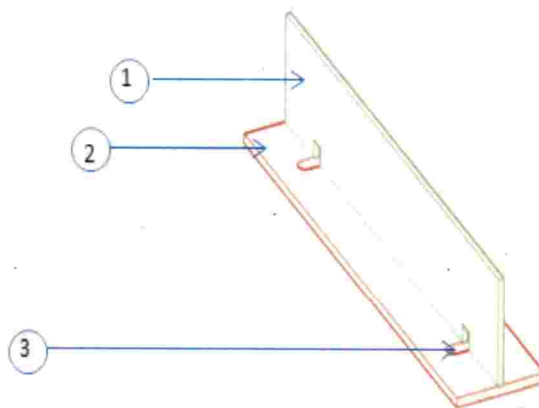

SLNo	Description
1	Flange
2	Base plate
3	Rivets

Isometric view

Fig. 3.16 Grouser (cleat) of the scale down prototype

### 3.4.1.3 Paddle

Paddle is a mechanical device for propelling a floating machine attached to the rear side. A revolving shaft attached with eight broad and angle blades is provided. It should be connected to hydraulic motor (MAT 500SH) through chain drive. The size of the paddle is 0.4x0.75m (Fig. 3.17).

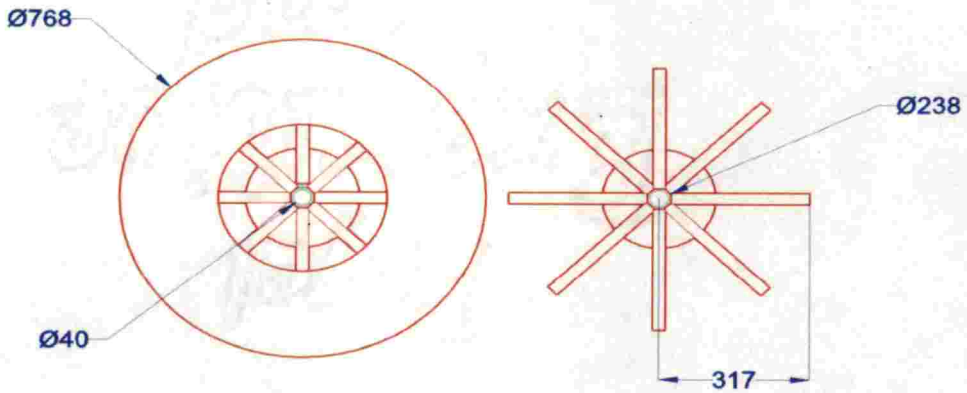

All dimensions in mm

Side view

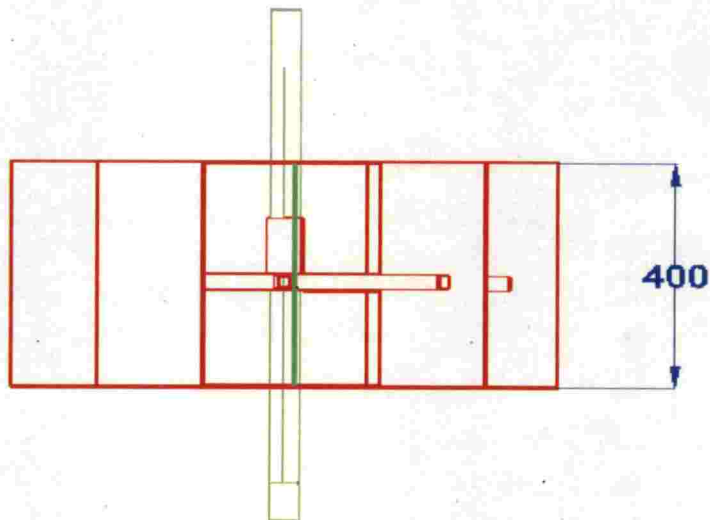

Top view

Fig. 3.17(a) Orthographic views of the paddle

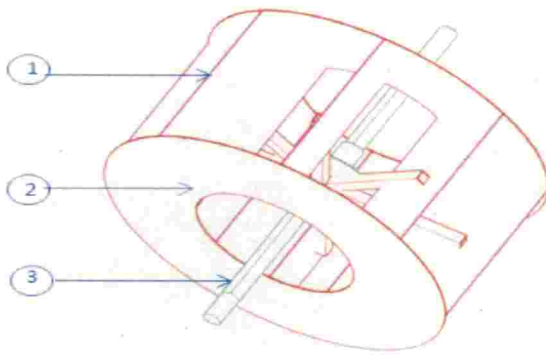

SLNo	Description
1	Angle blade
2	Casing
3	Shaft

**Isometric view**

**Fig. 3.17 Paddle of the scale down prototype**

### 3.4.2 Design of hydraulic system

The hydraulic system design for scale down Pokkali paddy harvester is designed as the existing KAU Pokkali paddy harvester. Hydraulic tank or reservoir is closed type reservoir which is the integral part of a system. The reservoir tank act as the main oil container for the entire system. The reservoir is designed in such a way that to drain the old, used oil and contaminants from the tank. Oil filter is placed on the top of the hydraulic tank and same is connected to return line hydraulic hoses so as to filter the contaminants in the oil. Sight and level gauges offer an inside view of fluid levels in the hydraulic tank. Based on the design and requirement of oil for the operation an around 150 litre capacity tank was fabricated and placed with good structural support in back of the operator seat. The overall dimension of the hydraulic tank is 0.5 x 0.6 x 0.5 m. Hydraulic pump is constant volume of fixed displacement pump and can work  $61 \text{ l min}^{-1}$ . They are relatively quiet and of simple construction. The pump is coupled to and driven by the prime mover of the system. The inlet side of the pump is connected to the reservoir: the outlet or pressure side is connected to the direction control valve and thus to rest of the system. Hydraulic motor used here is gerotor which is coupled with the gear box for rotation of complete assembly up to  $360^{\circ}$  on both the sides. Hydraulic motors can be instantly started, stopped, or

reversed under any degree of load; they can be stalled by overload without damage. The most familiar double acting cylinder is the single rod end is used to lift the front conveyor along with cutter bar and reel to the operational height. This type of cylinder provides power in both directions, with a pressure port at either end. In total there are five numbers of motors are used for the operations. In that two motors are fixed as floats in the left and right side. The two numbers of hydraulic motors are used as front and centre conveyor and one motor for the cutter bar operators at the time of operation. The diameter of the cylinder bore and piston are 40mm and 30mm. Seamless tubes with high wall thickness, higher tensile strength, better bending quality, etc. are some of the specific properties which make such tubes most suitable for use in many high pressure hydraulic systems. Hence, for the operation of floating harvester the seamless pipes with two size (22 OD/18 ID and 16 OD/12 ID). The 22 OD/18 ID pipes are used for inlet and outlet of hydraulic oil and 16 OD/12 ID pipes were used for the MAT 500SH hydraulic motors. The arrangements are made in such a way that all the operations like lifting and rotation can be done by the operator at the time of operation itself.

### **3.4.3 Design of harvesting unit**

Harvesting unit of the scale down Pokkali paddy harvester shall consist of a reel, cutter bar and conveyor. Reel delivers the stalks to the cutting mechanism, the cutter bar cuts the crop and conveys through front conveyor and is transferred to the central conveyor. The design of the complete unit was separately carried out for reel, cutter bar and conveyor units.

#### **3.4.3.1 Reel**

Reel delivers the stalks to the cutting mechanism. It holds the crop upright during cutting and delivers the cut stalks to the front conveyor. A fixed bat type reel (Fig. 3.18) assembly was used. It has a pentagonal frame fitted with five bats of length 180 cm fixed at a uniform spacing of 30 cm. The diameter of each bat shall be 5 cm. A total of eight fingers, each would and firmly at uniform intervals

of 15 cm. The reel assembly can be operated by a hydraulic motor (MR50) through chain drive. The design of the reel can be made according to the reel position with respect to cutter bar, reel speed with respect to forward speed, delivering the stalk to the cutting mechanism with minimum losses, holding the stalk upright while cutting and delivering the stalk to the conveyor. Also, the absolute velocity of the reel should be greater than the forward speed of the harvester.

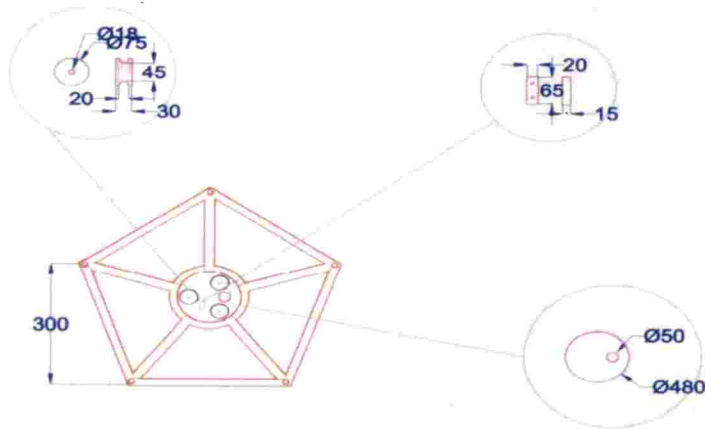

(a) Side view

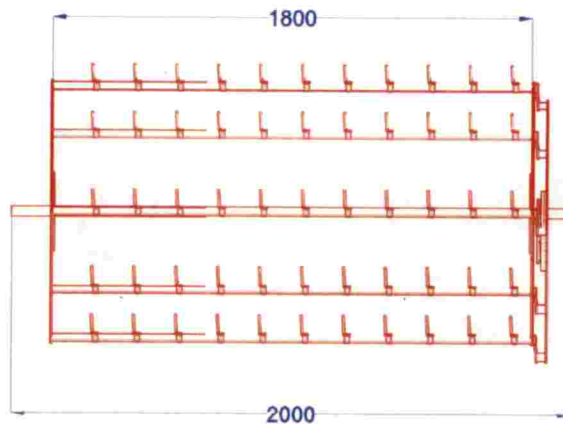

All the dimensions in mm

(b) Front view



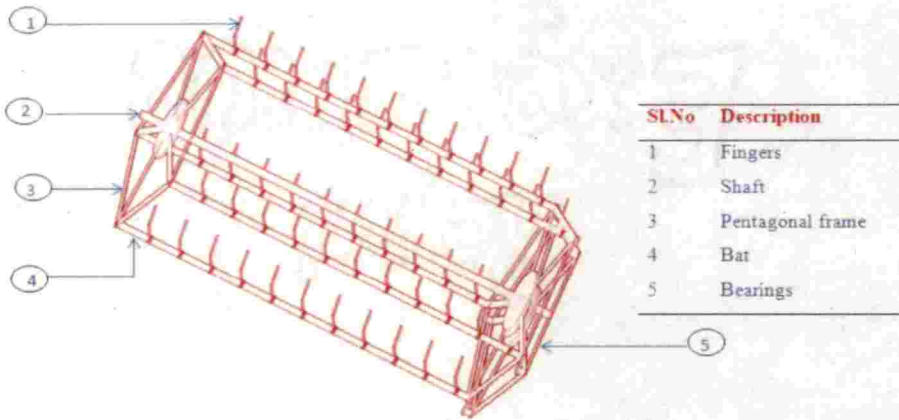

(c) Isometric view

**Fig. 3.18 Reel assembly of the scale down prototype**

The reel index was calculated based on the standard design procedures:

Reel index or velocity ratio ( $\lambda_i$ ) for reels is given by (Kanafojski and Karwowski, 1976):

$$\lambda_i = \frac{u_t}{v_m} \quad \dots 3.19$$

Where,

$u_t$  = tangential velocity of tip of the bats,  $m\ s^{-1}$

$v_m$  = forward velocity,  $m\ s^{-1}$

$$\text{Tangential velocity of tip of the bats, } u_t = \omega_r R_r \quad \dots 3.20$$

Where,

$\omega_r$  = angular velocity of reel,  $rad\ s^{-1}$

$R_r$  = radius of reel, mm

$$\omega_r = 2\pi N \quad (\text{assume } N = 16)$$

$$= 2 \times 3.142 \times 16$$

$$= 100.54 \text{ rad min}^{-1}$$

$$= \frac{100.54}{60}$$

$$= 1.675 \text{ rad min}^{-1}$$

$$u_t = \omega_r R_r$$

$$= 1.675 \times 0.30$$

$$= 0.5025 \text{ m s}^{-1}$$

$$\text{Reel index } (\lambda_i) = \frac{u_t}{v_m}$$

$$= \frac{0.5025}{0.416}$$

$$= 1.2$$

$$\text{Size (pitch) of reel } (P_r) = \frac{S_m}{Z} \quad \dots 3.21$$

Where,

$Z$  = number of bats on reel (5 Nos.)

$S_m$  = distance traversed by the machine during one revolution of the reel, mm

$$P_r = \frac{150}{5}$$

$$= 30 \text{ cm}$$

### 3.4.3.2 Cutter bar

Cutter bar of the scale down prototype is designed as that of the KAU Pokkali paddy harvester except its size. Cutter bar shall be operated by a hydraulic motor (MR50) through a crank pitman. A reciprocating type cutter bar of 1.8 m length having 24 knife sections, each having a stroke of 76.2 mm shall be provided. Standard size twin guards can also be provided on either ends of the cutter bar. These guards are provided to gather the crop and feed it to the cutter bar. In order to avoid slipping off the stalks serrated knife sections were attached

with the cutter bar. The pitch of serrated knife sections selected has to be two times smaller than the diameter of paddy stalk. Accordingly the pitch provided was 1.2 mm. Clearance between knives and ledger plates are to be maintained at 0.3 mm. The velocity of knife section shall be  $0.54 \text{ m s}^{-1}$  at a forward speed of  $1.5 \text{ km hr}^{-1}$ . Design of the cutter bar was carried out for finding the optimum speed of knife sections and number of knife sections based on the standard procedures.

The cutting of stalk is greatly affected by knife speed. The velocity of knife section is expressed as:  $V_k = R \times V_m$  ... 3.22

Where,

$V_k$  = Average knife velocity,  $\text{m s}^{-1}$

$V_m$  = Forward speed of harvester,  $\text{m s}^{-1}$

R = Velocity ratio

According to Klenin (1985) the angle between cutting edge and axis of knife section ( $\alpha$ ) shall be  $31^\circ$  the velocity should be  $1.5 \text{ m s}^{-1}$ . The value of R shall be in the range of between 1.3 to 1.4 with available cutter knife.

Taking  $R = 1.3$  and  $V_m = 0.416 \text{ m s}^{-1}$  ( $1.5 \text{ km h}^{-1}$ ) and putting values in above equation (3.23).

$$\begin{aligned} V_k &= 1.3 \times 0.416 \\ &= 0.54 \text{ m s}^{-1} \end{aligned}$$

$$\text{Number of knife sections} = \frac{L_c}{\text{size of knife section}} \quad \dots 3.23$$

Where,

$L_c$  = Length of the cutter bar, cm

$$\begin{aligned} \text{No. of knife sections} &= \frac{180}{7.62} \\ &= 23.62 \text{ (say, the cutter bar has 24 knife sections)} \end{aligned}$$

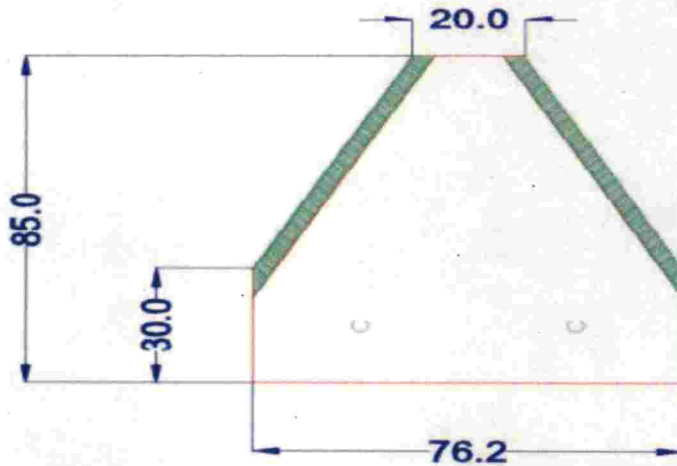

All dimensions in mm

**Fig. 3.19 Knife section of the cutter bar of the scale down prototype**

### 3.4.3.3 Front conveyor

The crop cut by the cutter bar is conveyed to the conveyor (Fig.3.20) for easy collection. It is made of 3.0 mm polypropylene sheet with equidistantly spaced rubber bars. The conveyor has to convey the bunch of cut crop continuously without blockage. It can be operated by a hydraulic motor MAH-400CB through the driving roller. This roller actuates the motion of the conveyor. The driven roller provided at the tail end, trails the conveyor forward and ensures continuous movement. The length of the conveyor belt shall be 1.7 x 0.6 m. The conveyor belt has to be wrapped over two rollers of 100 mm diameter and fixed on plummer blocks to stretch it firmly.

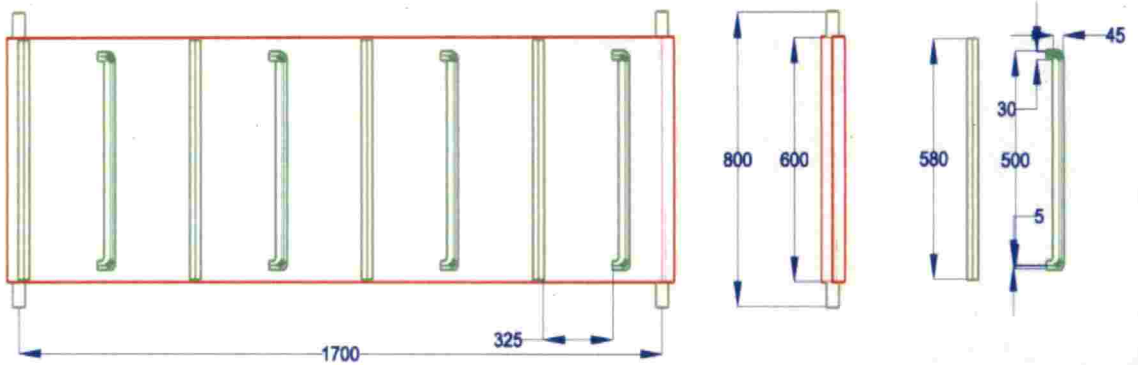

All dimensions in mm

(a) Top view

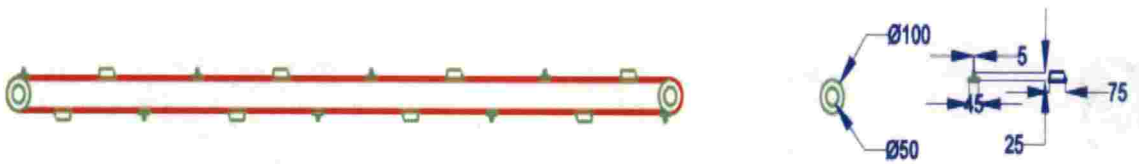

(b) Front view

**Fig. 3.20 Front conveyor of the scale down prototype**

Design of the front conveyor was carried out for finding the speed of conveyor belt, length of conveyor belt, pitch of lugs and lug height and clearance based on the standard procedures.

Speed of conveyor belt:

For lugged belt conveyor the belt speed is given by

$$V_b = \pi \frac{D_p N_p}{60} \quad \dots 3.24$$

Where,

$D_p$  = Diameter of conveyor belt roller, m

$N_p$  = Speed of conveyor belt roller, rpm

$V_b$  = Peripheral speed of flat belt,  $m\ s^{-1}$

$$V_b = 3.142 \frac{0.1 \times 89}{60}$$

$$= 0.47\ m\ s^{-1}$$

Length of conveyor belt:

It is calculated based on length of platform required for supporting the crop.

Length of platform = 1.7 m

Hence, centre to centre distance (C) between driving and driven roller is provided as 1.7 m.

The length of belt is given by

$$L = 2C + \pi \frac{(D+d)}{2} + \frac{(D+d)^2}{4C} \quad \dots\ 3.25$$

$$= 2 \times 1.7 + 3.142 \frac{(0.1+0.1)}{2} + \frac{(0.1+0.1)^2}{4 \times 1.7}$$

$$= 3.71\ m$$

The length of flat belt required for belt conveyor would be 3.71 m.

Pitch of lugs:

According to Devnani (1985), number of lugs on conveyor belt is

$$N = \frac{L}{P} \quad \dots\ 3.26$$

Where,

$N$  = Number of lugs on conveyor belt

$L$  = Length of belt, m

$P$  = Pitch of lugs, m

$$N = \frac{3.71}{0.25}$$

$$= 14.84 \text{ (say, the 15 number of lugs on conveyor)}$$

Lug height and clearance:

The lug height was fixed in such a way that the bunches of cut crop can be conveyed continuously without any blockage. This is only possible when conveyor output per unit time is greater than or equal to cutter output.

Therefore, output of conveyor  $\geq$  cutter bar output

$$h * w * \rho_2 \geq \rho_1 * w^2 * \frac{V_m}{V_c}$$

$$\text{Take } \frac{\rho_2}{\rho_1} = q = \frac{A_1}{A_2}$$

$$\text{Then, } h \geq \left(\frac{w^2}{q}\right) \times \left(\frac{V_m}{V_c}\right) \quad \dots 3.28$$

Where,

$h$  = height of lug, cm

$w$  = cutting width of machine, cm

$V_m$  = travelling speed of machine,  $m s^{-1}$

$V_c$  = speed of belt conveyor,  $m s^{-1}$

$\rho_1$  = Density of plant in field,  $g. cm^{-3}$

$\rho_2$  = Density of cut crop on the platform, g. cm<sup>-3</sup>

q = Gathered crop parameter

A<sub>1</sub> = Area of the field selected (say, 1 m<sup>2</sup>)

A<sub>2</sub> = Cross-sectional area of plants cut from the selected area of 1 m<sup>2</sup>

For all cases we can take A<sub>2</sub> = 0.015 m<sup>2</sup>

$$q = \frac{A_1}{A_2}$$

$$= \frac{1}{0.015} = 66.77$$

Putting values of q in the eqn. 3.14 we get,

$$h \geq \frac{120}{66.77} \times \frac{0.833}{0.833}$$

$$h = 1.8 \text{ cm}$$

Therefore, a clearance of 12-15 mm between conveyor belt and cutter unit was maintained.

#### 3.4.4 Centre conveyor

The crop is conveyed from the front conveyor to the centre conveyor (Fig.3.21) for easy collection and storage of the ear heads. It shall be made of 3.0 mm polypropylene sheet. The conveyor has to convey the bunch of cut crops. It shall be operated by a hydraulic motor MAH-400CB through the driving roller. This roller actuates the motion of the conveyor and the driven roller provided at the tail end trails the conveyor forward and ensures continuous movement. The length of the conveyor belt shall be 3.7 x 0.6 m. The conveyor belt has to be wrapped over two rollers of 100 mm diameter, which should be fixed on plummer blocks to stretch firmly.





Top view

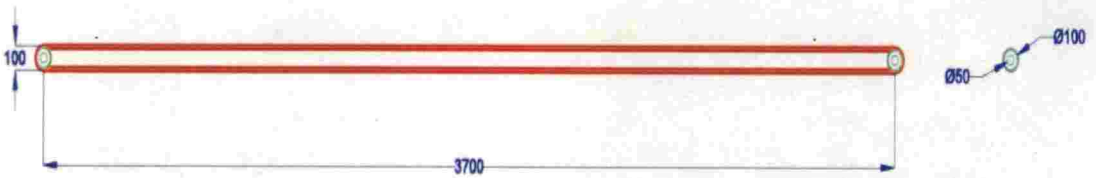

Front view

All dimensions in mm

**Fig. 3.21 Centre conveyor of the scale down prototype**

Design of the centre conveyor was also carried out for finding the length of conveyor belt based on the standard procedures:

Length of conveyor belt:

It is calculated based on length of horizontal platform required for supporting the crop

Length of horizontal platform = 3.7 m

Hence, centre to centre distance (C) between driving and driven roller is provided as 3.7 m.

The length of belt is given by

$$L = 2C + \pi \frac{(D+d)}{2} + \frac{(D+d)^2}{4C} \quad \dots \quad 3.29$$

$$= 2 \times 3.7 + 3.142 \frac{(0.1+0.1)}{2} + \frac{(0.1+0.1)^2}{4 \times 3.7}$$

$$= 6.582 \text{ m}$$

The length of flat belt required for back conveyor would be 6.582 m.

#### **3.4.4 Prime mover**

The capacity to meet the power requirement for harvesting is taken into consideration for the selection of the prime mover. The total weight of the scale down Pokkali paddy harvester comes around 1700 kg. In order to operate cutter bar, reel assembly, front conveyor, centre conveyor and float with hydraulic motors and then to lift the front conveyor with hydraulic cylinders sufficient energy should be supplied. Hence, 24 hp diesel engines have to be selected as the prime mover.

#### **3.4.5 Stability analysis**

Buoyancy is an upward force exerted by a fluid that opposes the weight of an immersed object. When the floating barge is at certain weight of harvester, it sinks to a certain depth. This allows adequate freeboard to prevent any water from getting on board. A floating object is stable if it tends to restore itself to an equilibrium position after a small displacement. The upward buoyancy force on an object acts through the centre of buoyancy, being the centroid of the displaced volume of fluid. The weight force on the object acts through its centre of gravity.

One of the key design criteria for the scale down prototype is the stability requirement of the floating structure. The barge has to be stable in water and unaffected by waves, wind, tides and at the same time safe for holding mass imposed on it.

##### **a) Transverse Stability**

Transverse centre of buoyance is the point through which the force of buoyancy supporting the vessel acts vertically upwards. Transverse centre of gravity is the point through which all of the weight of the vessel including deadweight items can be considered to act vertically downwards. When the machine is upright, both the centre of buoyancy and the centre of gravity are on the centre line of the vessel.

i.e.  $T_{CG} = 0$

$$T_{CG} = \frac{\sum T_{mt}}{\sum W_t} = 0 \quad \dots 3.30$$

Where,

$T_{CG}$  = transverse centre of gravity, m

$W_t$  = weight of the machine, t

$T_{mt}$  = transverse weight, t

The transverse centre gravity for scale down pokkali paddy harvester is zero. Hence the harvester is stable to floating on the water.

### b) Longitudinal Stability

If longitudinal centre of gravity and longitudinal centre of buoyancy are in the same vertical line and if there is no trimming moments on the machine,

$$L_{CG} = \frac{\sum L_{mt}}{\sum W_t} \text{ meters.} \quad \dots 3.31$$

Where,

$L_{CG}$  = longitudinal centre of gravity, m

$W_t$  = weight of the machines, t

$L_{mt}$  = longitudinal weight, t

### c) Vertical stability

Let the  $W$  be the weight of the Floating body and  $V_o$  be the submerged volume. Thus, downward weight of the body is balanced by the upward buoyancy force (B).

$$B = \rho_0 V_0 g$$

$$V_{CG} = \frac{\sum V_{mt}}{\sum W_t} \text{ meters.}$$

...3.32

Where,

$V_{CG}$  = Vertical centre of gravity, m

$W_t$  = weight of the machine, t

$V_{mt}$  = vertical weight, t

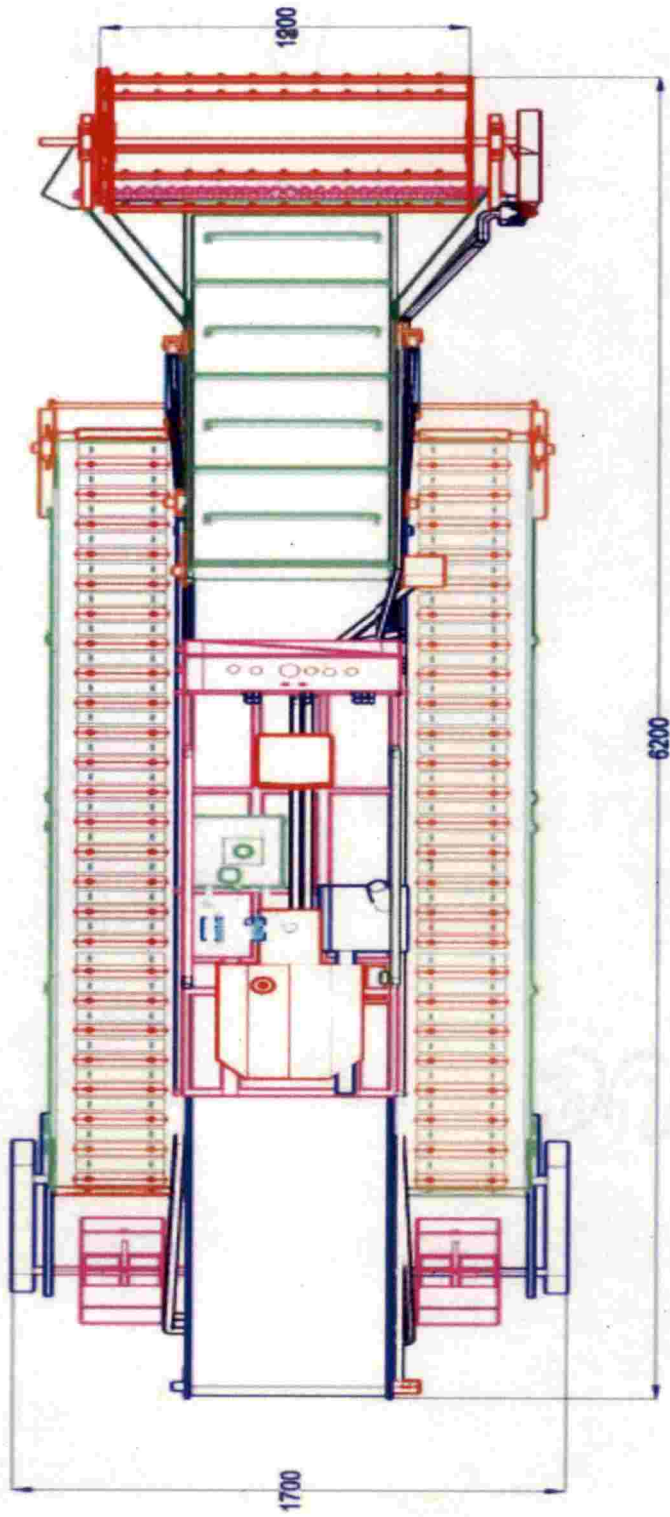

Fig.3.22 Top view of the scale down prototype

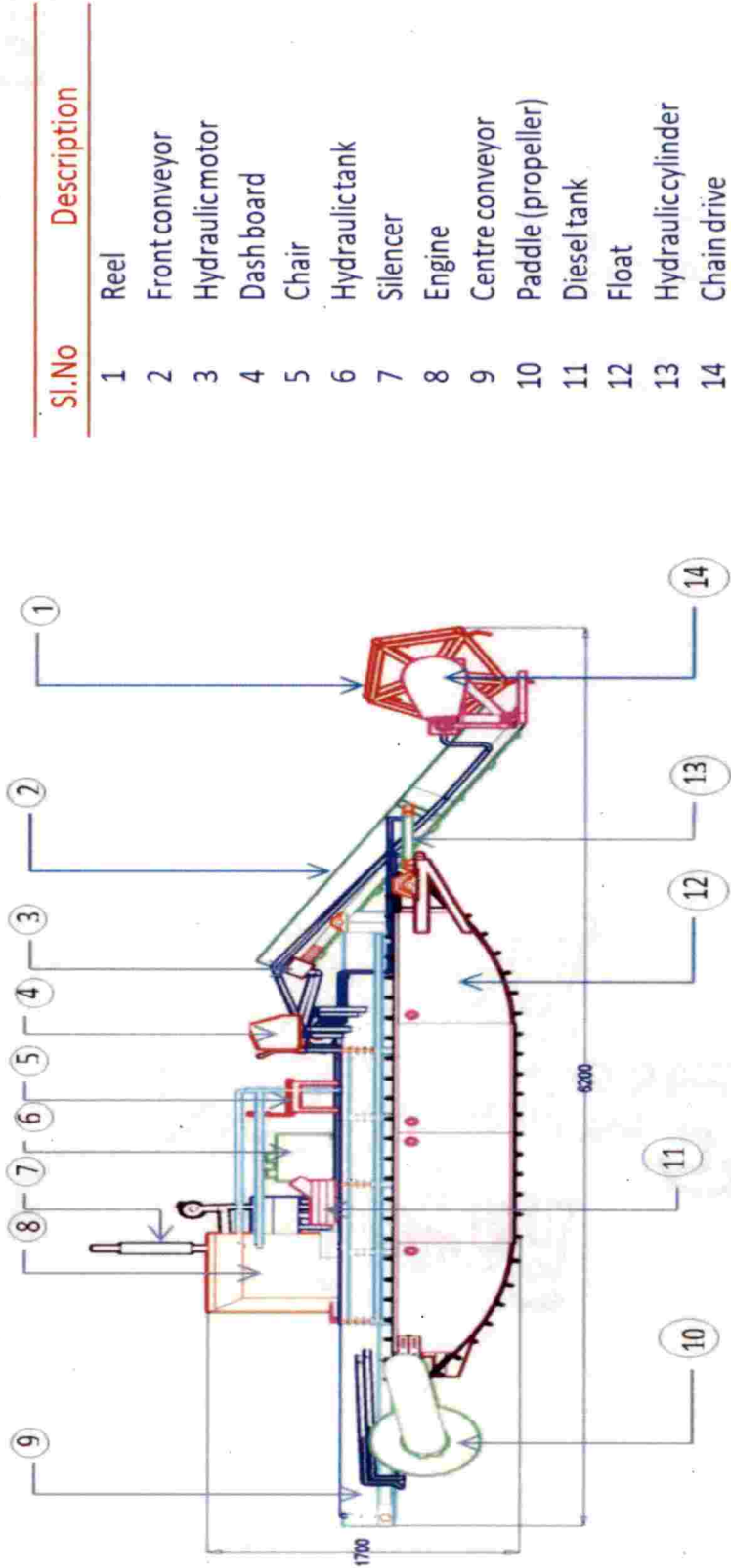

Fig.3.23 Side view of the scale down prototype

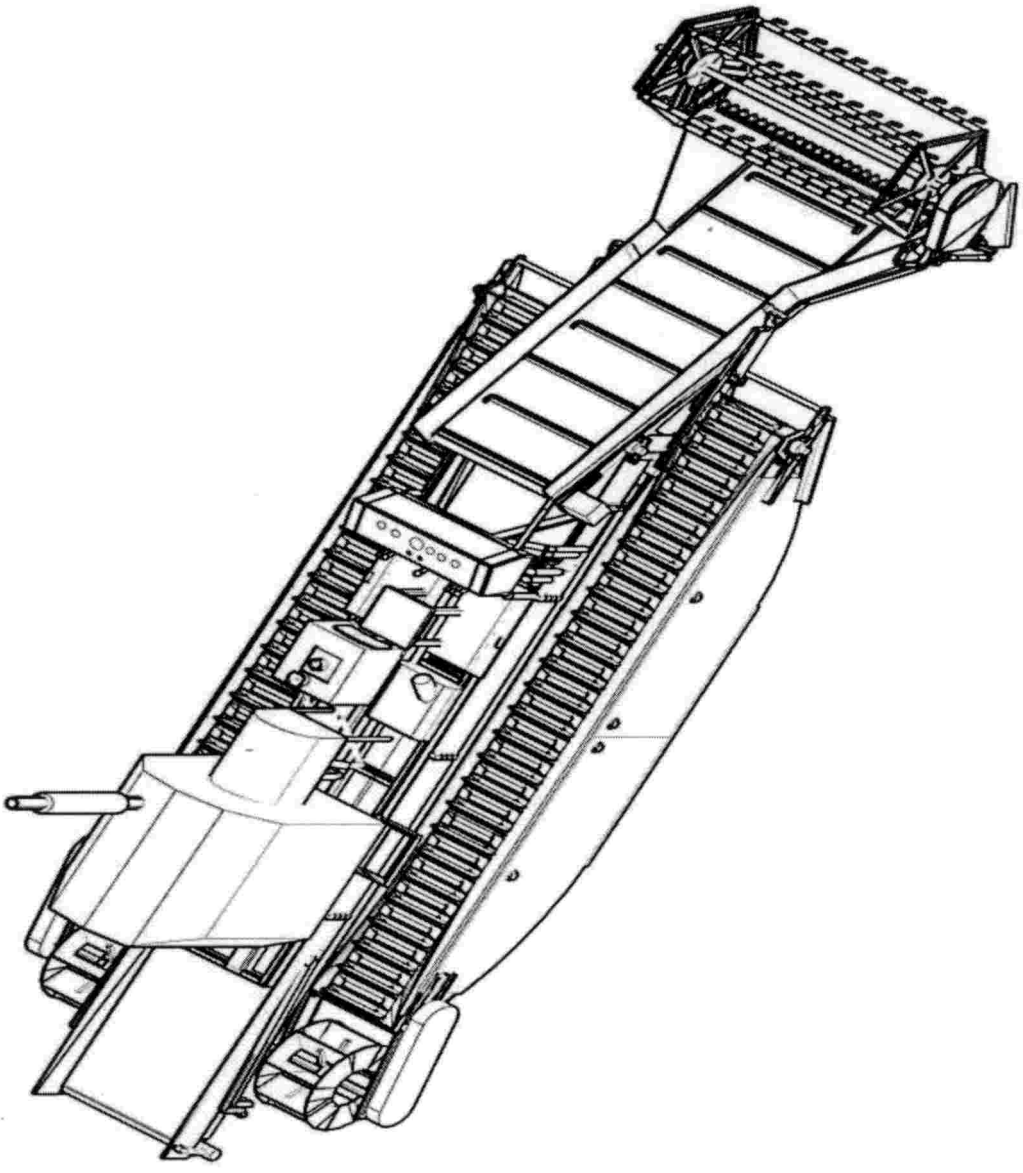

Fig.3.24 Isometric view of the scale down prototype

## RESULT AND DISCUSSION



## CHAPTER - IV

### RESULTS AND DISCUSSION

This chapter details the physical, mechanical and chemical properties of the Pokkali soil, design analysis of the KAU Pokkali paddy harvester and the design of its scale down proto type.

#### 4.1 Physical mechanical and chemical properties of soil

Physical properties such as moisture content, bulk density, shear strength and soil resistance influenced the traction and floatation of the Pokkali paddy harvester were determined.

##### 4.1.1 Moisture content

Moisture content was determined as by oven dry method. Soil samples from six different locations in the study area at specified intervals were determined using the equation as explained in section. 3.1.1. The average moisture content was found out as 44.5 per cent. The recorded values and its calculations are given in Appendix I.

##### 4.1.2 Bulk density

The bulk density of the soil in the experimental field was measured by core cutter method. The average bulk density of the soil was found to be  $1.658 \text{ g cm}^{-3}$ . The observations and calculations are given in Appendix II.

##### 4.1.3. Shear strength

Shear strength of soil at depths of 30, 45 and 60 cm was measured to find the strength of soil. The shear strength was determined by in-situ vane shear test apparatus as explained in section. 3.1.3. The average shear strength (S) at depths of 30, 45 and 60 cm of the soil from the experimental plot was found out as

0.0047 kg cm<sup>-2</sup>. The calculations of shear strength at different depths are given in Appendix III.

#### **4.1.4 Soil resistance**

The resistance of the soil in the experimental field was measured by a cone penetrometer. The average resistance of the soil was found out as 22.42 KN.m<sup>-2</sup>. The observations are given in Appendix IV.

#### **4.1.5 Chemical properties of the Pokkali soil**

Pokkali soils are classified as acid saline. The pH of the soil is 4.69. The soil is extremely acidic due to intermittent submergence and aeration. Aeration of the soil leads to oxidation of sulphides to sulphuric acid, which rapidly increases the soil acidity. Electrical conductivity of the soil was found to be very high with a mean value of 0.48 dSm<sup>-1</sup>. Inundation of sea water might have contributed significant amount of soluble salts and hence increases the electrical conductivity. Pokkali soil is rich in organic matter is 1.86 per cent, which is quite high and be attributed to addition of organic materials like FYM, compost and incorporation of straw and stubbles after harvest of rice besides maintaining moisture level at saturated condition. Chemicals available are N, P, K, Ca, Mg, Fe, Cu, Mn, Zn, S and B. The observations and calculations are given in Appendix V & VI.

#### **4.2 Design analysis of existing pokkali paddy harvester**

The design of the existing KAU Pokkali paddy harvester was analysed for finding out its safety and stability. Also envisaged its subsequent design of the scale down prototype. Its design features are explained in section 3.3.

##### **4.2.1 Float**

The float design of existing Pokkali paddy harvesting was explained in section 3.3.1. The overall dimension of the float is 4800 x 600 x 800 mm. traction belt made of 10.0 mm thickness polypropylene sheet was wound over the floats. Grousers 90 x 450 x 5 mm made of marine aluminium material are

selected to improve traction of the harvester as that of the prototype. The traction belt was driven by means of rollers. The speed of the roller was 45 rpm and float travelling speed was  $0.4713 \text{ ms}^{-1}$  ( $1.7 \text{ km hr}^{-1}$ ). The float details of the existing Pokkali paddy harvester are shown in Table 4.1.

**Table 4.1 Specification of float of the existing prototype**

Sl. No	Particulars	Specifications
1	Over all dimensions	
	i. Length, mm	4800
	ii. Width, mm	600
	iii. Height, mm	800
	iv. Material	MS sheet metal (Gauge-12)
2	Traction belt	
	i. Length, mm	12000
	ii. Width, mm	650
	iii. Thickness, mm	10
	iv. Material	Polypropylene
3	Legs / cleats	
	i. Length, mm	90
	ii. Width, mm	450
	iii. Thickness, mm	5
	iv. Material	Marine aluminium
4	Roller	
	i. Number of rollers	2
	ii. Diameter, mm	200
	iii. Speed of roller, rpm	45
	iv. Material	GI sheet (Gauge-12)
5	Air chamber	
	i. Length, mm	4860
	ii. Width, mm	1012

	iii.	Height, mm	500
	iv.	Material	MS sheet metal (Gauge-12)
6		Hydraulic motor	Model: MAT-500SH

#### 4.2.2 Hydraulic system

The hydraulic system of the harvester includes a motor, pump and direction control valves. The total hydraulic oil required to operate harvester is found to be  $60.6 \text{ l min}^{-1}$ . Hence, double acting hydraulic pump of  $61 \text{ l min}^{-1}$  capacity was selected calculations are given in Appendix VIII. The hydraulic cylinder design for existing Pokkali paddy harvester is described in section 3.3.2. The hydraulic cylinders have to lift 500 kg weight of front conveyer, cutter bar assembly and reel assembly and hence the pressure required was  $40 \text{ kg.cm}^{-2}$ . Hence, a hydraulic cylinder having outer diameter of 50 mm with piston rod diameter of 40 mm is used as the dimensions of the hydraulic cylinder.

The hydraulic motor design for existing Pokkali paddy harvester is described in section 3.3.2.4. The model: MR 50 was used for cutting unit having maximum speed of 970 rpm at displacement  $397 \text{ cc rev}^{-1}$ . The maximum oil flow of  $75 \text{ l min}^{-1}$  at maximum inlet pressure 175 bar. Model: MAH 400CB is used for both front and centre conveyor having a maximum motor speed 183 rpm at 86.4 Nm torque. The maximum oil flow of  $75 \text{ l min}^{-1}$  at a displacement of  $406.4 \text{ cc rev}^{-1}$  is suggested. Model: MAT 500SH is used for both left and right float having maximum motor speed 235 rpm at 122 Nm torque. The maximum oil flow  $125 \text{ l min}^{-1}$  at a displacement  $523.5 \text{ cc rev}^{-1}$  is used. The details of the hydraulic motor for existing Pokkali paddy harvester are shown in Table 4.2.

**Table 4.2 Specification of hydraulic motor**

Sl. No.	Particulars	Specifications				
		Max. speed(rpm)	Torque (Nm)	Max. oil flow(l/min)	Max. inlet pressure(bar)	Displacement (c.c/rev)
1	Hydraulic motors(types)					
	i. MR 50	970	61	75	175	397
	ii. MAH 400CB	183	86.4	75	200	406.4
	iii. MAT 500SH	235	122	125	210	523.5

**4.2.3 Reel**

The reel was designed for the KAU Pokkali paddy harvester is explained in section 3.3.3.1. The reel index is 1.7 and its pitch is 52 cm.

**4.2.4 Cutter bar**

The cutting unit was designed for the KAU Pokkali paddy harvester is explained in section 3.2.2. The reciprocating knife section of 2.1 m length of cutter bar was used. The knife section was of serrated blade in trapezoidal shape with 76.2 mm length and 85 mm height. High carbon steel was used as material for knife section. The 0.3 mm of clearance between knife and ledger plate is used to increase the efficiency of cutting unit. The details of the cutter bar used in the Pokkali paddy harvester are shown in Table 4.3.

**Table 4.3 Specification of cutting unit of the existing prototype**

Sl. No.	Particulars	Specifications
1	Type of cutter bar	Reciprocating knife sections
2	Length of cutter bar	2.1 m
3	Knife section	Standard
	i. Type	Trapezoidal
	ii. Blade	Serrated
	iii. Length x Height	76.2 mm, 85 mm
	iv. Angle between cutting edge and axis of knife section	33°
	v. Rake angle	22°
	vi. Pitch of serrating	1.2 mm
	vii. Clearance between knife and ledger plate	0.3 mm
	viii. Number of knife sections	27
	ix. Material	High carbon steel

#### 4.2.5 Front conveyor

The front conveyor designed for the KAU Pokkali paddy harvester is explained in section 3.3.3.3. The overall dimension of conveyor was 3000 x 1000 x 100 (Lx W x H) mm and 3 mm thickness polypropylene conveyor belt was selected to convey the cutting paddy stalk at operating speed of  $0.47 \text{ ms}^{-1}$ . Two rollers such as driven and driving rollers were used to operate the conveyor belt. It was provided with a lug having a pitch of height of 31.45 mm to convey the paddy stalk without any blockage and slipping. The front conveyor details of the Pokkali paddy harvester are shown in Table 4.4.

**Table 4.4 Specification of front conveyor of the existing prototype**

Sl. No	Particulars	Specifications
1	Over all dimensions	
	i. Length, mm	3000
	ii. Width, mm	1000
	iii. Height, mm	100
2	Conveyor belt	
	i. Length, mm	6318
	ii. Width, mm	1000
	iii. Thickness, mm	3
	iv. Material	Polypropylene
3	Pitch of lugs, mm	325
4	Lug height, mm	31.45
5	Roller	
	i. Number of rollers	2
	ii. Diameter, mm	100
	iii. Speed of roller, rpm	89
	iv. Material	GI sheet (Gauge-12)
6	Hydraulic motor	Model: MAH-400CB
7	Speed of conveyor belt, ms <sup>-1</sup>	0.47

#### 4.2.6 Centre conveyor

The centre conveyor was designed for the KAU Pokkali paddy harvester is explained in section 3.3.3.4. The overall size provided for conveyor was 6330 x 1000 x 100 mm. A made of polypropylene of 3.0 mm thickness conveyor belt was selected to convey and store of the paddy stalk at an operating speed of 0.416 ms<sup>-1</sup>. The rollers were provided to operate the conveyor belt. The centre conveyor details of the Pokkali paddy harvester are shown in Table 4.5.

**Table 4.5 Specification of centre conveyor of the existing prototype**

Sl. No	Particulars	Specifications
1	Over all dimensions	
	i. Length, mm	6330
	ii. Width, mm	1000
	iii. Height, mm	100
2	Conveyor belt	
	i. Length, mm	12980
	ii. Width, mm	1000
	iii. Thickness, mm	3
	iv. Material	Polypropylene
3	Roller	
	i. Number of rollers	2
	ii. Diameter, mm	100
	iii. Speed of roller, rpm	79
	iv. Material	GI sheet (Gauge-12)
4	Hydraulic motor	Model: MAH-400CB

#### 4.2.7 Stability of harvester

The stability of KAU Pokkali paddy harvesting is explained in section 3.3.5. The overall size of the KAU Pokkali paddy harvester is 9.6 x 2.2 x 2.2 m with a total weight of about 3000 kg. A KAU Pokkali paddy harvester is designed in such a way that to suit for fragmented Pokkali areas. The vertical centre of gravity of the scale down prototype is 0.874 m, longitudinal centre of gravity is 4.512 m and transverse centre of gravity is zero. As the transverse centre of gravity is zero, scale down Pokkali paddy harvester is stable to float and longitudinal centre of gravity lies near to the centre and adjacent to the front and rear side of the harvester, it become a well-balanced machine. A draft of 47 cm



for floats, 32 cm for air chamber was observed for the KAU Pokkali paddy harvester of 3 tonnes.

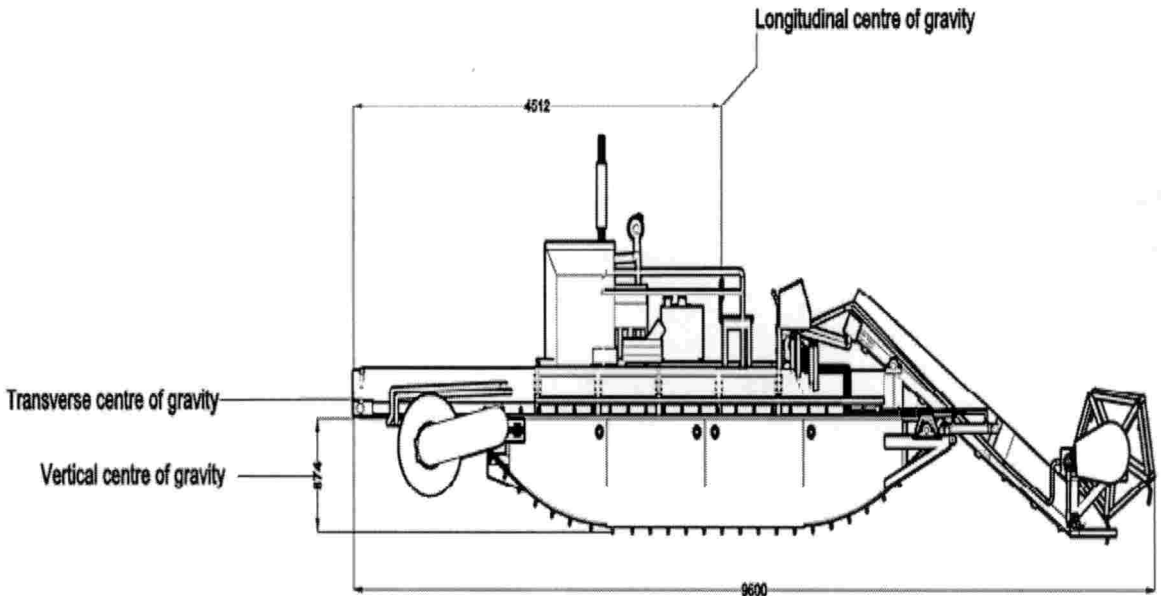

All the dimension in mm

**Fig. 4.1 Stability aspects of the scale down prototype**

### 4.3 Design of scale down prototype

The scale down Pokkali paddy harvester was designed in such a way to operate the harvester in fragmented fields of pokkali areas. Its design features are explained in section 3.4.

#### 4.3.1 Float

The float design of the scale down Pokkali paddy harvesting is explained in section 3.4.1. The overall dimension of float is 300 x 450 x 600 mm, 10 mm thickness polypropylene traction belt and overall dimension of cleat is 90 x 450 x

5 mm and marine aluminium material for cleats is selected to improve traction of the harvester. The driven and driving rollers are operating the traction belt. The speed of the roller is 77 rpm and float travelling speed is  $0.416 \text{ m s}^{-1}$  ( $1.5 \text{ km hr}^{-1}$ ). The float details of the scale down Pokkali paddy harvester are shown in Table 4.6.

**Table 4.6 Specification of float of the scale down prototype**

Sl. No	Particulars	Specifications
1	Over all dimensions	
	i. Length, mm	3000
	ii. Width, mm	450
	iii. Height, mm	600
	iv. Material	MS sheet metal (Gauge-12)
2	Traction belt	
	i. Length, mm	6600
	ii. Width, mm	450
	iii. Thickness, mm	10
	iv. Material	Polypropylene
3	Legs / cleats	
	i. Length, mm	90
	ii. Width, mm	300
	iii. Thickness, mm	5
	iv. Material	Marine aluminium
4	Roller	
	i. Number of rollers	2
	ii. Diameter, mm	100
	iii. Speed of roller, rpm	77
	iv. Material	GI sheet (Gauge-12)
5	Air chamber	
	i. Length, mm	3000

	ii.	Width, mm	600
	iii.	Height, mm	400
	iv.	Material	MS sheet metal (Gauge-12)
6		Hydraulic motor	Model: MAT-500SH

### 4.3.2 Hydraulic system

The hydraulic system of the harvester viz., hydraulic motor, cylinder and pump. The total hydraulic oil required to operate harvester is  $60.6 \text{ l min}^{-1}$ . So, we selected capacity  $(45+16) \text{ l min}^{-1}$  double acting hydraulic pump calculations are given in Appendix VIII. The hydraulic cylinder design for existing Pokkali paddy harvester was described in section 3.4.2. The hydraulic cylinders have to lift 500 kg weight of front conveyer, cutter bar assembly and reel assembly and pressure required  $40 \text{ kg cm}^{-2}$ . So, we selected 50 mm outer diameter and 40 mm piston rod diameter of hydraulic cylinder.

The hydraulic motor design for existing Pokkali paddy harvester is described in section 3.4.2. The model: MR 50 used for cutting unit, maximum speed 970 rpm at displacement  $397 \text{ cc rev}^{-1}$ . and maximum oil flow is  $75 \text{ l min}^{-1}$  at maximum inlet pressure 175 bar. Model: MAH 400CB is used for both front and back conveyer having maximum motor speed 183 rpm at 86.4 Nm torque and maximum oil flow  $75 \text{ l min}^{-1}$  at displacement  $406.4 \text{ cc rev}^{-1}$ . Model: MAT 500SH is used for both left and right float having maximum motor speed 235 rpm at 122 Nm torque and maximum oil flow  $125 \text{ l min}^{-1}$  at displacement  $523.5 \text{ cc rev}^{-1}$ . The hydraulic motor details of the existing Pokkali paddy harvester.

### 4.3.3 Reel

The reel was designed for the scale down prototype was explained in section 3.4.3.1. The reel index is 1.2 and pitch of reel is 30 cm.

#### 4.3.4 Cutter bar

The cutting unit was designed for the scale down Pokkali paddy harvester is explained in section 3.4.3.2. The reciprocating knife section of 1.8 m length of cutter bar was used. The knife section was of serrated blade in trapezoidal shape with 76.2 mm length and 85 mm height. High carbon steel was used as material for knife section. The 0.3 mm of clearance between knife and ledger plate is used to increase the efficiency of cutting unit. The cutter bar details of the Pokkali paddy harvester are shown in Table 4.7

**Table 4.7 Specification of cutting unit of the scale down prototype**

Sl. No.	Particulars	Specifications
1	Type of cutter bar	Reciprocating knife sections
2	Length of cutter bar	1.8 m
3	Knife section	Standard
	i. Type	Trapezoidal
	ii. Blade	Serrated
	iii. Length x Height	76.2 mm, 85 mm
	iv. Angle between cutting edge and axis of knife section	33°
	v. Rake angle	22°
	vi. Pitch of serrating	1.2 mm
	vii. Clearance between knife and ledger plate	0.3 mm
	viii. Number of knife sections	16
	ix. Material	High carbon steel

### 4.3.5 Front conveyor

The front conveyor designed for the scale down Pokkali paddy harvester was explained in section 3.4.3.3. The overall dimension of conveyor was 1700 x 600 x 100 mm and 3 mm thickness polypropylene conveyor belt was selected to convey the cutting paddy stalk at operating speed of  $0.47 \text{ m s}^{-1}$ .

Two rollers such as driven and driving rollers were used to operate the conveyor belt. It was provided with a lug having pitch of height of 18 mm. To convey paddy stalk without any blockage and slipping. The front conveyor details of the Pokkali paddy harvester are shown in Table 4.8.

**Table 4.8 Specification of front conveyor of the scale down prototype**

Sl. No	Particulars	Specifications
1	Over all dimensions	
	i. Length, mm	1700
	ii. Width, mm	600
	iii. Height, mm	100
2	Conveyor belt	
	i. Length, mm	3700
	ii. Width, mm	600
	iii. Thickness, mm	3
	iv. Material	Polypropylene
3	Pitch of lugs, mm	250
4	Lug height, mm	18
5	Roller	
	i. Number of rollers	2
	ii. Diameter, mm	100
	iii. Speed of roller, rpm	89
	iv. Material	GI sheet (Gauge-12)
6	Hydraulic motor	Model: MAH-400CB
7	Speed of conveyor belt, $\text{m s}^{-1}$	0.47

### 4.3.6 Centre conveyor

The centre conveyor is designed for the scale down Pokkali paddy harvester was explained in section 3.4.4. The overall size provided for conveyor was 3700 x 600 x 100 mm. A thickness of 3 mm polypropylene conveyor belt was selected to convey and store of the cutting paddy stalk at operating speed of  $0.416 \text{ m s}^{-1}$ . The driven and driving rollers were provided to operate the conveyor belt. The centre conveyor details of the Pokkali paddy harvester are shown in Table 4.9.

**Table 4.9 Specification of centre conveyor of the scale down prototype**

Sl. No	Particulars	Specifications
1	Over all dimensions	
	i. Length, mm	3700
	ii. Width, mm	600
	iii. Height, mm	100
2	Conveyor belt	
	i. Length, mm	6582
	ii. Width, mm	600
	iii. Thickness, mm	3
	iv. Material	Polypropylene
3	Roller	
	i. Number of rollers	2
	ii. Diameter , mm	100
	iii. Speed of roller, rpm	79
	iv. Material	GI sheet (Gauge-12)
4	Hydraulic motor	Model: MAH-400CB

#### **4.2.7 Stability of harvester**

The stability of scale down Pokkali paddy harvesting is explained in section 3.4.5. The overall size of the newly designed scale down prototype is 6.2 x 1.7 x 1.7 m with a total weight of about 1700 kg. A scale down prototype of the harvester is designed in such a way that to suit for fragmented Pokkali areas. The vertical centre of gravity of the scale down prototype is 0.58 m, longitudinal centre of gravity is 2.67 m and transverse centre of gravity is zero. As the transverse centre of gravity is zero, scale down Pokkali paddy harvester is stable to float and longitudinal centre of gravity lies near to the centre and adjacent to the front and rear side of the harvester, it become a well-balanced machine. A draft of 47 cm for floats, 39 cm for air chamber was observed for the scale down prototype of harvester of 1.70 tonnes.

SUMMARY AND CONCLUSION



## CHAPTER - V

### SUMMARY AND CONCLUSIONS

Pokkali rice farming is an age old, eco- friendly, organic method of paddy cultivation followed in the coastal regions of Ernakulum, Alappuzha and Thrissur Districts bordering the Arabian Sea in the state of Kerala. Pokkali rice is the oldest variety of rice in Kerala cultivated for the past 3000 years. This rice has high market value and also numerous medicinal properties attributed to it. Further, it has been awarded the status of registered Geographical Indication (GI) in the year 2008. In Pokkali farming system, rice cultivation is followed by prawn cultivation.

In conventional method of Pokkali paddy harvesting, manual harvesting using sharp sickles are practiced. For the harvesting, highly labour intensive, drudgery and more time consuming operations are required. This has curtailed the area under Pokkali from 25,000 ha, a few decades back to a mere 8,500 ha now. Out of which, only 5,500 ha is under rice cultivation, the rest is either left fallow or used only for prawn farming. The paddy cultivation goes on decreasing every year. Hence, there was a great demand for a suitable harvesting machine, especially for harvesting the paddy, which is under water at the time of harvest due to tidal effects.

To overcome these problems, KAU Pokkali paddy harvester was developed at KCAET, Tavanur. It was operated by the hydraulic system, which consisted of a hydraulic cylinders and motors with a control valve. The Pokkali paddy harvester consists of floating barge, hydraulic system and harvesting unit viz. reel, cutter bar and conveyors. There were several problems associated with the construction especially with respect to the over size and weight, the manoeuvrability become a great problem for transportation and operation in small paddy lands. It necessitated designing a scale down proto type of the harvester to operate in all Pokkali areas with easy transportation and good manoeuvrability features.

The physical and mechanical properties of soil affecting the design analysis of Pokkali paddy harvester were studied. The four major soil properties, *viz.*, moisture content, bulk density, shear strength and soil resistance affecting the trafficability to the Pokkali paddy harvester were determined in the present study. Soil samples from different locations of the Pokkali fields were collected in containers to determine the above mentioned properties of the soil. The tests were conducted in the Soil and Water Laboratory at RRS, Vyttila and KCAET, Tavanur.

The soil test was conducted at RRS, Vyttila. The Pokkali soil having soil shear strength  $0.0047 \text{ kg cm}^{-2}$  and soil resistance  $22.42 \text{ KN.m}^{-2}$ . The physical and mechanical properties of the soil have an effect directly or indirectly at the soil-machine interface. The major two physical properties of soil *viz.*, moisture content and bulk density and the most influential mechanical property of soil *viz.*, shear strength and soil resistance were determined using standard test procedures. Bore holes at depths of 30, 45 and 60 cm were dug out. Torque applicator was fixed on the stand with the help of spikes. A vane size of 37.5 mm diameter was selected. The vane was lowered to the above required depths. It was pushed downward with a moderate steady force up to a depth of 50mm below the bottom of the bore hole and allowed for 5 minutes after the insertion of the vane. The vane was rotated at the rate of  $0.1^\circ$  per second, this in turn help to get a uniform rate of 12 turns per minute. Vane was rotated completely ten times to disturb the soil. Torque indicator dial gauge reading was noted at half minute interval and rotation of vane was continued until the reading drops appreciable from the maximum was observed and recorded.

The KAU Pokkali paddy harvester developed was studied in detail. The scale down Pokkali paddy harvester was designed for harvesting the panicles (ear heads) of paddy crop. The harvester was operated by a hydraulic system. The total weight of the scale down Pokkali paddy harvester comes around 1700 kg. In order to operate with this, a sufficient hydraulic lifting capacity and operate harvesting unit (reel, cutter bar and conveyors) and floating barge was needed. Hence, the tractor engine of 24 hp selected as the prime mover. The capacity to

meet the hydraulic oil requirement for operating scale down Pokkali paddy harvester is  $61 \text{ l min}^{-1}$ , double acting pump and hence a tank capacity of 150 litres was selected. 50 mm diameter of hydraulic cylinder with 30 cm of stroke is selected to lift the 500 kg of front frame with reel assembly, cutter bar and conveyor. It required  $40 \text{ kg cm}^{-2}$  pressure to lift the frame. The five different types of hydraulic motors are used to operate the scale down Pokkali paddy harvester. The MR50 hydraulic motor for cutter bar and to operate 200 rpm of cutter bar a total discharge of  $10 \text{ l min}^{-1}$  is required. The MAH 400CB hydraulic motors for conveyors to convey the ear head, the belt speed at  $5 \text{ m min}^{-1}$  and a total discharge of  $5.3 \text{ l min}^{-1}$  is required. The MAT 500SH hydraulic motors for floats to traverse the harvester, the speed at  $25 \text{ m min}^{-1}$  and a total discharge of  $20 \text{ l min}^{-1}$  is required.

In addition to the two floats, a separate air chamber can be provided in between the two floats. It is partially immersed in a fluid and experiences an upward force (buoyancy) equal to the weight of the fluid displaced. The size of float is  $3.0 \times 0.45 \times 0.6 \text{ m}$  (L x W x H). The side slope has to be made  $34^\circ$  to facilitate the track belt and it can be constructed with MS sheet metal (Gauge-12) of thickness 2 mm and size of chamber  $3.0 \times 0.6 \times 0.4 \text{ m}$ . In this designed float and chamber can be able to float the water at weight of 1700 kg.

Draft (depth) of the float and chamber at a weight of harvester 1700 kg is 47 and 39 cm respectively. This floating harvester is an amphibious type to facilitate movement both in standing water and land. If the standing water is less; it can be traverse through traction belt.

The stability of KAU Pokkali paddy harvester was founded out in terms of vertical centre of gravity for harvester is 0.874 m and longitudinal centre of gravity which was at 4.512 m and transverse centre of gravity at zero. If transverse centre of gravity is zero, KAU Pokkali paddy harvester is stable to float. When the longitudinal centre of gravity is centre to the front and rear side of the harvester, it is balanced. Accordingly, the stability of scale down Pokkali

paddy harvester is also designed and suggested that the vertical centre of gravity for harvester as 0.54 m and longitudinal centre of gravity as 2.67 m and transverse centre of gravity as zero.

174473



REFERENCES

## REFERENCES

- [Anonymous]. 2007. Vane shear test. *Indian insti. of Technol. Department of Civil Eng.* pp: 1-2 (in Press).
- Abhilash Joseph, E. 2016. Rice cultivation in saline tracts of Kerala. *Int. J. of Fish. and Aquat. Stud.* 4(4): 355-358.
- Adeniran, K.A. and Babatunde, O.O. 2010. Investigation of Wetland Soil Properties affecting Optimum Soil Cultivation. *J. of Eng. Sci. and Technol.* pp: 23-26.
- Agodzo, S.K. and Adama, I. 2003. Bulk density, cone index and water content relations for some ghanaian soils. Kwame Nkrumah *Univ. Sci. Technol.* Kumasi-Ghana. pp: 6-8.
- Aman Pande, Ankit Jain, Moinak Banerjee and Sangeeth, P. 2015. Designing of a hand-held Combined Harvester for Indian Farming Markets. *Int. J. of Mod. Eng. Res.*
- Ananth, K., Vaitla Rakesh and Pothamsetty Kasi Visweswarao, 2013. Design and selecting the proper conveyor-belt. *Int. J. of Adv. Eng. Technol.*
- Antony, A., Mercy, A., and Shaju, S.S. 2014. Effect of Rotational Pokkali cultivation and Shrimp farming on the Soil Characteristics of two different Pokkali field at Chellanam and Kadamakudi, Kochi, Kerala. *Int. Res. J. of Environ. Sci.* Vol. 3(9): 61-64.
- Arman Jalali and Reza Abdi, 2014. The Effect of Ground Speed, Reel Rotational Speed and Reel Height in Harvester Losses. *J. of Agric. and Sustain.* ISSN 2201-4357 Vol (5): 221-231.
- Awadhwal, N.K. and Singh, C.P. 1985. Dynamic behaviour of wet soil, tillage and traction in wet soil. *Agric. Mechanisation in Asia, Afr. and Latin Am.* 16(2): 11-90.
- Bansal, R. K. 2005. Fluid Mechanichs and Hydraulic Machines. Nineth edition, Laxmi Publications (P) Ltd., New Delhi-110006, India.

- Bautista, E., Regalado, J.S., Juliano, A., Ishihara, S., Monobe, H., Ramos, J., and Molinawe, L. 2005. The PhilRice-JICA rotary rice reaper: redesigning a technology for Filipino farmers and manufacturers. *Rice is life: scientific perspectives for the 21st century* 7, pp: 229-232.
- Bawatharani, R., Jayatissa, D.N., Dharmasena, D.A., and Bandara, 2013. Impact of Reel Index on Header Losses of Paddy and Performance of Combine Harvesters. *Trop. Agric. Res.* Vol. 25 (1): 1-13
- Blake, G.R. and Hartge, K.H. 1986. Methods of soil analysis. Part 1, physical and mineralogical methods. 2nd ed., Agronomy Monograph No. 9. Madison, WI: *Soil Sci. Soc. of Am.* pp: 363-375.
- Brandelik, A. and Hibner, C. 1996. Soil moisture determination - accurate, larger and deep. *Phys. Chem. Earth.* 21(3): 157-160.
- Celik, A. 2001. Design and operating characteristics of a push type cutter bar mower Present Situation of Agricultural Mechanization in Turkey. Country Report for Group Training Course on Farm Machinery Design. Japan International Cooperation Agency, TBIC, JR, 01-203, Tsukuba, Japan.
- Dalayeli, H. and Madineh, A. R. 2002. Industrial Hydraulics System Design. 2<sup>nd</sup> Edn., Kanoon Pazhoresh Press, Esfehan, Iran.
- Darling, J. and Tilley, D.G. 1999. A centralized hydraulic system for passenger cars. *J. Automobile Eng.*, 213: 425-434.
- Ephrem Zeleke Kassa., and Ing Zewdu Abdi, 2014. Design and Modification of Appropriate Reel Mechanism to Harvest Tef Crop. *Int. J. of Res. in Mechanical Eng.* Vol. (2): 15-25
- Gayathri, R. N. and Raveendran, K. 2009. Exploration of untapped potentiality of coastal paddy fields of Kerala (India)-A case study. *Middle-East J. Sci. Res.* 4 (1): 44 - 47.

- Gamez-Montero, Salazar, E., Castilla, R., Freire J., Khamashta, M., and Codina, E. 2009. Misalignment effects on the load capacity of a hydraulic cylinder. *Int. J. Mech. Sci.* ISSN NO: 1510–1213.
- Giles, R. V., Evett, J. B., and Liu, C. 1994. Fluid Mechanics and Hydraulics. McGraw-Hill, Singapore. 58p.
- Grigal, D.F., Brovold, S.L., Nord, W.S., and Ohmann, L.F. 1989. Bulk density of soils and peat in the north central United States. *Can. J. Soil Sci.* pp: 895–900.
- Jackson, M.L. 1958. *Soil Chemical Analysis* (Indian Reprint, 1967). Prentice Hall of India Private Ltd., New Delhi, 498 p.
- Jagadeesha, T. 2012. Fluid Power Control Systems, *Mech. Eng. Dep.* NIT Calicut pp: 1-12
- Jagdishwar Sahay, 1971. *Elements of Agricultural Engineering*. Standard publishers and distributors. 1705-B Nai Sarak, post box No. 106, Delhi-110006.
- Jayan, P.R. and Sathyanathan, N. 2010. Overview of farming practices in the water-logged areas of Kerala, India. *Int. J. Agri. & Bio. Eng.* 3(4):1-16.
- Jayan, P.R., 2012. Development of Innovative Farm Mechanisation Package for Kerala, Kerala Agricultural University, KAU (P.O), Thrissur.
- Jiang Youshan and Zou Guangde, 2009. Study on hydraulic motor selection of full hydraulic bulldozer. *Construction mechanization*, pp: 45-48.
- Jignesh Vasava and Hitesh Raiyani, 2016. Modeling and Analysis of Telescopic Hydraulic Cylinder for Increase Load Capacity. *Int. J. for Sci. Res. & Dev.* Vol. 4(3).
- Kaewprakaisaengkul, C.1985. Harvesting of water hyacinth. *J. of agric. Mechanization in Asia, Afr. and Latin Am.*



- Kanafojsi, C.Z., and Karwowski, W.C., 1976. In: *Agricultural Machines, Theory and construction*. Crop Harvesting Machines. United States Departments of Agriculture, and National Foundation, Washinton, D.C, II.
- Kepner, R.A., Roy Bainer, and Barger, E. L., 1978. *Principles of Farm Machinery*. CBS publishers and Distrubutors.
- Klenin, N.I., Popv, I.F., and Sakun, V.A., 1985. *Agricultural Machines*. Amerind Publishing Company Pvt. Ltd, New Delhi, India.
- Koh, H.S., and Lim, Y.B., 2009. The floating platform at the Marine Bay, Singapore, Structural engineering International: *J. of the int. asso. For Bridge and struct. Eng.*
- Maly, V. and Kucera, M. 2014. Determination of mechanical properties of soil under laboratory conditions. *Res. Agr. Eng.*, pp: 66–69.
- Manorama Thampatti, K.C. and Padma kumar, K.G. 1999. Rice Bowl in Turmoil: The Kuttanad Wetland Ecosystem. *Nat. Watch Resonance*.
- Mohammad Abolhassani, 2011. Rotational satiability of floating bodies. Dept. of navel architecture.
- Mullen, J.K. and M. Williams, 2004. Maintenance and repair expenditures: Determinants and tradeoffs with new capital goods. *J. Econ. Bus.*, 56: 483-499.
- Oduori, M. F. 1994. Basic Principles of Combine Harvester Reel Design and Operation. An Unpublished Ph. D. Thesis. Fukuoka, Japan: Kyushu University.
- Omofunmi, O. E., Ebifemi, S. A., and Eweina, A. B. 2016. Design of Water Hyacinth (*Eichhornia crassipes*) Harvester. *J. of Sci. Res. & Rep.* 10(5): 1-10.
- Pillai, S.M. 2003. Fishery and production of shrimps from perennial and seasonal fields of Kerala. *Indian J. Fish.* 50(2):173–180.

- Reddy, K.M. 2002. Engineering properties of soils based on laboratory testing. Department of Civil and Materials Engineering University of Illinois, Chicago. pp: 1-174.
- Sahay, K.M. and Singh, K.K., 1994. *Unit Operations of Agricultural Processing*. Vikas Publishing House Private Limited, New Delhi, India.
- Sasidharan, N. K., Abraham, C.T. and Rajendran, C.G. 2012. Spatial and temporal integration of rice, fish, and prawn in the coastal wetlands of central Kerala, India. *J. of Trop. Agric.* 50(2): 15-23.
- Shamna, N. 2014. Study on farmers perception on prospects and problems of pokkali rice farming in the state of Kerala. Published MSc Thesis, Department of Agricultural Extension College of Agriculture, Acharya n. G. Ranga Agricultural University Rajendranagar, Hyderabad-500 030.
- Sharma, D.N., and Mukesh, S., 2008. *Principles and problems, Farm Machinery Design*. Jain brothers publications.
- Srivastava, A. K., Goering, C. E., and Rohrbach, R. P. 1993. *Engineering principles of agricultural machines*. *Am. Soc. of Agri. Eng.* pp: 414-416.
- Steven, k. and Omi. 1985. Soil Compaction: Effects on Seedling Growth. Intermountain Nurseryman's Association Meeting Fort Collins, Colorado. pp: 1-6.
- Tupper, and Eric, 1996. Introduction to Naval Architecture. Oxford, England: Butterworth-Heinemann.
- Vanaja, T. 2013. KAIPAD - a Unique, Naturally Organic, Saline Prone Rice Ecosystem of Kerala, India, *Am. J. of Environ. Prot.* Vol. 2(2): 42-46.
- Varshney, A.C., Tiwari, P.S., Suresh Narang and Mehta, C.R., 2004. *Data Book for Agricultural Machinery Design*.
- Wang Jiwei, Zhang Hongjia and Huang Yi, 2005. Hydraulic and pneumatic transmission. Beijing:Mechanical Industry Press.

Xie Fuxiang, 2014. Design on Full-Hydraulic Drive System of Corn Combine Harvester. *Int. Conf. on Mech. Electr. Ind. and Control Eng.*

APPENDICES

## Appendix - I

### Determination of moisture content

Sl.no	Weight of container (w <sub>1</sub> )	Weight of container + wet soil (w <sub>2</sub> )	Weight of container + dry soil (w <sub>3</sub> )	Moisture content ( $\frac{w_2 - w_3}{w_3 - w_1}$ )	Moisture content (%)
1	4	300	204	0.48	48
2	4	390	288	0.359	35.9
3	4	310	220	0.459	45.9
4	4	310	200	0.561	56.1
5	4	334	244	0.375	37.5
6	4	432	302	0.436	43.6

#### Sample calculations:

Mass of container, m<sub>1</sub> (g) = 4

Mass of container + wet soil, m<sub>2</sub> (g) = 300

Mass of container + dry soil, m<sub>3</sub> (g) = 204

Moisture content, % =  $[(m_2 - m_3) / (m_3 - m_1)] \times 100$

$$= (300 - 204) / (204 - 4)$$

$$= 96 / 200$$

$$= 0.48 \times 100$$

Moisture content (%) = 48.00

## Appendix - II

## Determination of bulk density

Mass of core cutter(g)	Mass of core cutter + wet soil(g)	Mass of wet soil (g)	Height of core cutter (cm)	Internal diameter (cm)	Volume (cm <sup>3</sup> )	Bulk density (g/cm <sup>3</sup> )
984	2640	1656	12.5	10	981.25	1.687
984	2608	1624	12.5	10	981.25	1.655
984	2632	1648	12.5	10	981.25	1.679
984	2394	1410	12.5	10	981.25	1.436
984	2656	1672	12.5	10	981.25	1.703
984	2748	1764	12.5	10	981.25	1.79

**Sample calculations:**

Mass of core cutter, g = 984

Mass of core cutter + wet soil, g = 2640

Mass of wet soil, g = 1656

Height of core cutter, cm = 12.5

Internal diameter, cm = 10

Volume, cm<sup>3</sup> = 981.2

Bulk density, g cm<sup>-3</sup> = Mass/ volume

= 1656 / 981.25

= 1.687 g cm<sup>-3</sup>

**Appendix - III**  
**Determination of Shear strength**

Soil depth (cm)	Height of vane cm	Diameter of vane cm	Torque dial gauge reading kg-cm	Shear strength kgf-cm <sup>2</sup>
30	10	5	2.6	0.0056
45	10	5	1.8	0.00392
60	10	5	2.2	0.0048

**Sample calculation:**

Torque in kgf. cm = 2.6

Diameter of vane, cm = 5

$$\text{Shear strength kgf-cm}^2, S = \frac{T}{\pi \left( \frac{D^2 H}{2} + \frac{D^3}{6} \right)}$$

If  $H = 2D$  the equation reduces to

$$\begin{aligned} S &= \frac{3T}{11D^3} \\ &= \frac{3 \times 2.6}{11 \times D^3} \\ &= 0.0056 \text{ kgf-cm}^2 \end{aligned}$$



**Appendix - IV**  
**Determination of soil resistance**

Sl. no	Soil depth (cm)	Dial readings							Penetro meter reading from curve(N)	Penetrat ion force (KN)	Resistance (KN/m <sup>2</sup> )
		1	2	3	4	5	6	mean			
1	10	14.5	16	23	26	20	18	19.58	20	0.196	24.968
2	15	20.7	22	9.5	22	10	15	16.53	17	0.166	21.146
3	25	17	15	16	20	12	19	16.5	17	0.166	21.146

**Sample calculation:**

Soil depth = 10

Mean dial gauge reading, PR = 20 N

Penetration force, PF = PR x 0.0098

$$= 20 \times 0.0098$$

$$= 0.196 \text{ KN}$$

Resistance = PF / BA

$$= 0.196 / (\pi/4 \times (0.10)^2)$$

$$= 0.196 / 0.00785$$

$$= 24.968 \text{ KN.m}^{-2}$$



## Appendix – V

## Determination of Physical properties of Pokkali soil

Clay %	59.78
Silt %	17.67
Coarse sand %	4.10
Fine sand %	18.45
Texture	Clay
Bulk density Mg m <sup>-3</sup>	0.71
Moisture content% (0.3 bar)	44.91
Moisture content% 15 bar	28.11

## Appendix - VI

## Determination of chemical properties of Pokkali soil

Chemical properties		
pH	EC (dSm <sup>-1</sup> )	OC (%) (kg ha <sup>-1</sup> )
4.69	0.48	1.86

## Available nutrients

N	P	K	Fe	Cu	Zn	Mn	B	Ca	Mg	S
(kg ha <sup>-1</sup> )	(kg ha <sup>-1</sup> )	(kg ha <sup>-1</sup> )	(mg/kg)	(mg/kg)	(mg/kg)	(mg/kg)	(mg/kg)	(mg/kg)	(mg/kg)	(mg/kg)
110.39	68.3	105.9	869.4	0.6016	0.5744	33.21	0.419	152.9	11.951	15.105

### Appendix - VII

#### Specifications of existing KAU Pokkali paddy harvester

PARTS	SPECIFICATIONS
Overall Dimensions	Length - 9.67 m Width - 2.22 m Height - 2.22 m
Float	Length – 4.80m Width - 0.60m Height – 1.00 m
Depth	Empty - 40 cm Loaded - 65 cm
Engine	45 HP Diesel engine
Pump	Hydraulic double pump
Motors for Conveyors and Cutters	Hydraulic motors (M+S make)
Lift	Hydraulic Cylinders
Conveyors	Metal or polypropylene belt suitable for paddy
Fuel & Oil Storage Tanks	Fuel Tank – 50 litres ; Oil Tank – 150 litres
Navigation	Rubber belts with flaps, Independently operated for forward, reverse & turning
Operator Cabin	Comfortable seat with canopy  Storage boxes for tools, life jackets etc.
Controls	Hydraulic DC valves with levers for hand operation

---

Control Panel	Ammeter, Voltmeter, RPM meter, Oil Pressure Gauge, Temperature gauge, Hour Meter, Light Switches
Transportation & Handling	Hooks provided for lifting and hauling
Finish	Epoxy - Corrosion resistant ; Colour – As per customer choice
Material for Construction	Marine aluminum steel ; SS is optional at extra cost

---

## Appendix - VIII

### Design of hydraulic system

#### 1) Hydraulic cylinders

Diameter of cylinder = 40 mm

Radius = 20 mm

Area of bore =  $\pi \times R^2$

$$= 3.142 \times 2^2$$

$$= 12.5 \text{ cm}^2$$

Weight to be lifted = 500 kgf

Since force (F) = P x A

Pressure required (P) =  $\frac{F}{A}$

$$= \frac{500}{12.5}$$

$$= 40 \text{ kg cm}^{-2}$$

#### 2) Hydraulic motors

##### i. Cutter bar hydraulic motor

Model: MR 50

Discharge: 50 cc rev<sup>-1</sup>

Assume RPM as 200

Total discharge = 200 x 50

$$= 10000 \text{ cc rev}^{-1}$$

$$= 10 \text{ lit min}^{-1}$$

##### ii. Front conveyor hydraulic motor

Model: MAH- 400CB

Discharge: 400 cc rev<sup>-1</sup>

Assume: 5 m min<sup>-1</sup>

$$\text{RPM of roller} = \frac{5}{0.3768}$$

$$= 13.26 \text{ rpm}$$

$$\begin{aligned}\text{Total discharge} &= 400 \times 13.26 \\ &= 5307 \text{ cc rev}^{-1} \\ &= 5.3 \text{ lit min}^{-1}\end{aligned}$$

**iii. Back conveyer hydraulic motor**

Model: MAH- 400CB

Discharge: 400 cc rev<sup>-1</sup>

Assume: 5 m min<sup>-1</sup>

$$\begin{aligned}\text{RPM of roller} &= \frac{5}{0.3768} \\ &= 13.26 \text{ rpm}\end{aligned}$$

$$\begin{aligned}\text{Total discharge} &= 400 \times 13.26 \\ &= 5307 \text{ cc rev}^{-1} \\ &= 5.3 \text{ lit min}^{-1}\end{aligned}$$

**iv. Float- Left hydraulic motor**

Model: MAT 500SH

Discharge: 500 cc rev<sup>-1</sup>

Assume: 1.5 km/hr or 25 m min<sup>-1</sup>

With diameter of drive roller = 200 mm

$$\begin{aligned}&= 2\pi r \\ &= 2 \times 3.142 \times 0.1 \\ &= 0.628 \text{ m}\end{aligned}$$

$$\begin{aligned}\text{RPM of roller} &= \frac{25}{0.628} \\ &= 40 \text{ rpm}\end{aligned}$$

$$\begin{aligned}\text{Total discharge} &= 500 \times 40 \\ &= 20000 \text{ cc rev}^{-1} \\ &= 20 \text{ lit min}^{-1}\end{aligned}$$

**v. Float- Right hydraulic motor**

Model: MAT 500SH

Discharge: 500 cc rev<sup>-1</sup>

Assume: 1.5 km/hr or 25 m/min

With diameter of drive roller = 200 mm

$$= 2\pi r$$

$$= 2 \times 3.142 \times 0.1$$

$$= 0.628 \text{ m}$$

$$\text{RPM of roller} = \frac{25}{0.628}$$

$$= 40 \text{ rpm}$$

Total discharge = 500 x 40

$$= 20000 \text{ cc rev}^{-1}$$

$$= 20 \text{ lit min}^{-1}$$

Total oil flow = 10+5.3+5.3+20+20

$$= 60.6 \text{ lit min}^{-1}$$

## Appendix - IX

### Selection of prime mover of the existing prototype

#### Cutter bar:

$$\text{Power} = \frac{2\pi NT}{60} \quad (\text{Jagdishwar Sahay, 1971})$$

Assume 200 rpm

For cutter bar 20-30 N draft is required per meter

For 2.1 m energy required is =  $2.1 \times 30 = 63 \text{ N}$

For reel the torque equation is  $T = \frac{1}{2} I\omega^2$

$$\begin{aligned} I &= mk^2 \\ &= 44 \times 0.45^2 \\ &= 8.91 \end{aligned}$$

Where, I = moment of inertia

$\omega$  = angular velocity

m = mass, kg

k = radius of gyration, m

$$\begin{aligned} T &= 0.5 \times 8.91 \times 1.67^2 \\ &= 12.4245 \text{ Nm} \end{aligned}$$

$$\begin{aligned} \text{Power} &= \frac{2\pi NT}{60} \\ &= \frac{2 \times 3.142 \times 210 \times 205.425}{60} \\ &= 4518 \text{ w} \\ &= \frac{4518}{746} \\ &= 6.05 \text{ hp} \end{aligned}$$

Where, N = speed of the knife section, rpm

T = torque, Nm

**Front conveyor:**

$$HP = \frac{\text{Belt speed, m/min}}{0.3048} \times \frac{(A+B)(3.281 L)}{100} \quad (\text{Sahay, K.M. and Singh, K.K. 1994})$$

Assume 31 rpm at a speed of 2.0 km hr<sup>-1</sup>

$$HP = \frac{31}{0.3048} \times \frac{(0.60+0.00350)(3.281 \times 3)}{100}$$

$$= 6.04 \text{ hp}$$

Where,

L = length of belt, m

A & B = constants (frictional resistance of the belt and pulley)

**Centre conveyor:**

$$\text{Power} = \frac{\text{Belt speed, m/min}}{0.3048} \times \frac{(A+B)(3.281 L)}{100}$$

Assume 25 rpm at a speed of 2.0 km hr<sup>-1</sup>

$$\text{Power} = \frac{25}{0.3048} \times \frac{(0.60+0.00350)(3.281 \times 6.63)}{100}$$

$$\text{Power} = 10.76 \text{ hp}$$

Where,

L = length of belt, m

A & B = constants (frictional resistance of the belt and pulley)

**Float - 1:**

$$\text{Power} = \frac{2\pi NT}{60}$$

Assume 45 rpm at a speed of 2.0 km hr<sup>-1</sup>

$$= \frac{2 \times 3.142 \times 45 \times 1220}{60}$$

$$= 5750 \text{ w}$$

$$= \frac{5750}{746}$$

$$= 7.7 \text{ hp}$$



Where,

N = speed of the rollers, rpm

T = torque, Nm

**Float - 2:**

$$\text{Power} = \frac{2\pi NT}{60}$$

Assume 45 rpm at a speed of 2.0 km hr<sup>-1</sup>

$$= \frac{2 \times 3.142 \times 45 \times 1220}{60}$$

$$= 5750 \text{ w}$$

$$= \frac{5750}{746}$$

$$= 7.7 \text{ hp}$$

Where, N = speed of the rollers, rpm

T = torque, Nm

Total power required for motors in hp for KAU Pokkali paddy harvester is

$$6.05 + 6.04 + 10.78 + 7.7 + 7.7 = 38.25 + 3.825 = 42.07 \text{ hp}$$

Assuming 10% of losses.

## Appendix - X

### Selection of prime mover of the scale down prototype

#### Cutter bar:

$$\text{Power} = \frac{2\pi NT}{60} \quad (\text{Jagdishwar Sahay, 1971})$$

Assume 200 rpm

For cutter bar 20-30 N draft is required per meter

For 1.8 m energy required is =  $1.8 \times 30 = 54 \text{ N}$

For reel the torque equation is  $T = \frac{1}{2} I\omega^2$

$$\begin{aligned} I &= mk^2 \\ &= 30 \times 0.30^2 \\ &= 2.7 \end{aligned}$$

Where, I = moment of inertia

$\omega$  = angular velocity

m = mass, kg

k = radius of gyration, m

$$\begin{aligned} T &= 0.5 \times 2.7 \times 1.67^2 \\ &= 3.765 \text{ Nm} \end{aligned}$$

$$\begin{aligned} \text{Power} &= \frac{2\pi NT}{60} \\ &= \frac{2 \times 3.142 \times 210 \times 169.7}{60} \\ &= 3732.38 \text{ w} \\ &= \frac{3732.38}{746} \\ &= 5 \text{ hp} \end{aligned}$$

Where, N = speed of the knife section, rpm

T = torque, Nm

**Front conveyor:**

$$\text{Power} = \frac{\text{Belt speed, m/min}}{0.3048} \times \frac{(A+B)(3.281 L)}{100} \quad (\text{Sahay, K.M. and Singh, K.K. 1994})$$

Assume 31 rpm at a speed of 2.0 km hr<sup>-1</sup>

$$\text{Power} = \frac{31}{0.3048} \times \frac{(0.36+0.00224)(3.281 \times 1.7)}{100}$$

$$\text{Power} = 2.05 \text{ hp}$$

Where,

L = length of belt, m

A & B = constants (frictional resistance of the belt and pulley)

**Centre conveyor:**

$$\text{Power} = \frac{\text{Belt speed, m/min}}{0.3048} \times \frac{(A+B)(3.281 L)}{100}$$

Assume 25 rpm at a speed of 2.0 km hr<sup>-1</sup>

$$\text{Power} = \frac{25}{0.3048} \times \frac{(0.36+0.00224)(3.281 \times 3.7)}{100}$$

$$\text{Power} = 3.6 \text{ hp}$$

Where,

L = length of belt, m

A & B = constants (frictional resistance of the belt and pulley)

**Float - 1:**

$$\text{Power} = \frac{2\pi NT}{60}$$

Assume 72 rpm at a speed of 2.0 km hr<sup>-1</sup>

$$= \frac{2 \times 3.142 \times 72 \times 446}{60}$$

$$= 3363.2 \text{ w}$$

$$= \frac{3363.2}{746}$$

$$= 4.5 \text{ hp}$$

Where,

N = speed of the rollers, rpm

T = torque, Nm

**Float - 2:**

$$\text{Power} = \frac{2\pi NT}{60}$$

Assume 72 rpm at a speed of 2.0 km hr<sup>-1</sup>

$$= \frac{2 \times 3.142 \times 72 \times 446}{60}$$

$$= 3363.2 \text{ w}$$

$$= \frac{3363.2}{746}$$

$$= 4.5 \text{ hp}$$

Where,

N = speed of the rollers, rpm

T = torque, Nm

Total power required for motors in hp for scale down prototype is

$$5+2.05+3.6+4.5+4.5 = 19.65 + 1.965 = 21.6 \text{ hp}$$

Assuming 10% of losses.

## Appendix - XI

## Centre of gravity of the components of KAU Pokkali paddy harvester

Sl. No	Part List	Weight (t)	LCG (m)	VCG (m)	TCG (m)	LMT	VMT	TMT
1	i)Propeller (Left)	0.00257	1.136	0.672	0.75	0.00292	0.00172	0.00192
	ii)Propeller (Right)	0.00257	1.136	0.672	-0.75	0.00292	0.00172	-0.00192
2	Hydraulic motor for back conveyer	0.0123	0.08	0.937	0.585	0.000984	0.01152	0.00719
3	i)Hydraulic motor for float(Left)	0.02298	0.16	0.028	0.02	0.0036768	0.00064	0.00045
	ii)Hydraulic motor for float(Right)	0.02298	0.16	0.028	-0.02	0.0036768	0.00064	-0.00045
4	i)Float (Left)	0.66317	4.249	0.57	0.75	2.817809	0.37800	0.4973
	ii)Float(Right)	0.66317	4.249	0.57	-0.75	2.817809	0.37800	-0.4973
5	Air chamber	0.48528	4.249	0.45	0	2.061954	0.21837	0
6	Centre conveyer	0.139	3.405	0.9	0	0.473295	0.1251	0
7	Chassis	0.122	4.9725	1.29	0	0.606645	0.15738	0
8	Engine	0.254	2.77	2.055	0	0.70358	0.52197	0
9	Hydraulic tank	0.13698	4.062	1.405	-0.29	0.55641	0.19245	-0.0405
10	Diesel tank	0.0462	3.52	1.26	0.375	0.16262	0.05821	0.01732
11	Chair	0.02	4.862	1.33	0	0.09724	0.0266	0

12	Front conveyor	0.132	7.53	1.29	0	0.99396	0.17028	0
13	Front conveyor frame	0.1216	7.53	1.29	0	0.91564	0.15686	0
14	Hydraulic motor for front conveyor	0.0123	3.005	1.29	0.75	0.03696	0.01586	0.00922
15	i)Hydraulic cylinder (Left)	0.006	7.53	1.29	1.57	0.04518	0.00774	0.00942
	ii)Hydraulic cylinder(Right)	0.006	7.53	1.29	-1.57	0.04518	0.00774	-0.00942
16	Cutter bar	0.075	9.145	1.29	0	0.68587	0.09675	0
17	Hydraulic motor for cutter bar	0.0068	9.145	1.79	1	0.06218	0.01217	0.0068
18	Reel assembly	0.044	9.61	1.79	0	0.42284	0.07876	0
	<b>TOTAL</b>	<b>2.9969</b>	<b>100.035</b>	<b>23.487</b>	<b>2.414</b>	<b>13.5193</b>	<b>2.61854</b>	<b>0</b>

**A) Vertical stability**

$$V_{CG} = \frac{\sum V_{mt}}{\sum Wt} \text{ meters.}$$

$$= \frac{2.618}{2.996}$$

$$= 0.874 \text{ m}$$

**B) Longitudinal Stability**

$$L_{CG} = \frac{\sum L_{mt}}{\sum Wt} \text{ meters.}$$

$$= \frac{13.52}{2.996}$$

$$= 4.512 \text{ m}$$

**C) Transverse Stability**

$$T_{CG} = \frac{\sum T_{mt}}{\sum Wt}$$

$$= \frac{0}{2.996}$$

$$= 0$$

## Appendix - XII

## Centre of gravity of the components of scale down Pokkali paddy harvester

Sl. No	Part List	Weight (t)	LCG (m)	VCG (m)	TCG (m)	LMT	VMT	TMT
1	i)Propeller (Left)	0.0185	0.62	0.43	-0.554	0.01147	0.007955	-0.01024
	ii)Propeller (Right)	0.0185	0.62	0.43	0.554	0.01147	0.007955	0.01024
2	Hydraulic motor for back conveyer	0.0123	0.06	0.618	0.38	0.000738	0.007601	0.00467
3	i)Hydraulic motor for float(Left)	0.0229 8	1.14	0.53	-0.27	0.026197	0.012179	-0.00620
	ii)Hydraulic motor for float(Right)	0.0229 8	1.14	0.53	0.27	0.026197	0.012179	0.006204
4	i)Float (Left)	0.267	2.815	0.37	-0.54	0.751605	0.09879	-0.14418
	ii)Float (Right)	0.267	2.815	0.37	0.54	0.751605	0.09879	0.14418
5	Air chamber	0.096	2.815	0.29	0	0.27024	0.02784	0
6	Centre conveyor	0.139	1.5	0.618	0	0.2085	0.085902	0
7	Chassis	0.1	2.21	0.731	0	0.221	0.0731	0
8	Engine	0.18	1.681	1.273	0	0.30258	0.22914	0
9	Hydraulic tank	0.137	2.71	1.05	-0.15	0.37127	0.14385	-0.02055
10	Diesel tank	0.03	2.67	0.9	0.168	0.0801	0.027	0.00504
11	Chair	0.02	3.071	1.022	0	0.06142	0.02044	0
12	Front conveyor	0.117	4.91	0.55	0	0.57447	0.06435	0



13	Front conveyor frame	0.059	4.91	0.55	0	0.28969	0.03245	0
14	Hydraulic motor for front conveyor	0.0123	3.98	1.02	0.43	0.048954	0.012546	0.00528
15	i)Hydraulic cylinder (Left)	0.006	4.89	0.523	-0.39	0.02934	0.003138	-0.00234
	ii)Hydraulic cylinder(Right)	0.006	4.89	0.523	0.39	0.02934	0.003138	0.00234
16	Cutter bar	0.04	5.8	0.03	0	0.232	0.0012	0
17	Hydraulic motor for cutter bar	0.0068	5.7	0.37	0.6	0.03876	0.002516	0.00408
18	Reel assembly	0.03	6.08	0.4	0	0.1824	0.012	0
19	Man	0.1						
	<b>TOTAL</b>	<b>1.70</b>	<b>67.02</b>	<b>13.128</b>	<b>1.424</b>	<b>4.5078</b>	<b>0.985</b>	<b>0</b>

**a) Vertical stability**

$$V_{CG} = \frac{\sum V_{mt}}{\sum Wt} \text{ meters.}$$

$$= \frac{0.985}{1.70}$$

$$= 0.58 \text{ m}$$

**b) Longitudinal Stability**

$$L_{CG} = \frac{\sum L_{mt}}{\sum Wt} \text{ meters.}$$

$$= \frac{4.50}{1.70}$$

$$= 2.67 \text{ m}$$

**c) Transverse Stability**

$$T_{CG} = \frac{\sum T_{mt}}{\sum Wt}$$

$$= \frac{0}{1.70}$$

$$= 0$$

**Appendix - XIII****Specifications of scale down prototype of the Pokkali paddy harvester**

<b>PARTS</b>	<b>SPECIFICATIONS</b>
Overall Dimensions	Length - 6.2 m Width - 1.7 m Height - 1.7 m
Float	Length – 3.0m Width - 0.45m Height – 0.60 m
Engine	24 HP Diesel engine
Pump	Double acting hydraulic pump
Motors for Conveyors and Cutters	Hydraulic motors (M+S make)
Lift	Hydraulic Cylinders
Conveyors	polypropylene
Fuel & Oil Storage Tanks	Fuel Tank – 40 litres ; Oil Tank – 150 litres
Operator Cabin	Comfortable seat with canopy storage boxes for tools, life jackets etc.
Controls	Hydraulic DC valves with levers for hand operation
Control Panel	Ammeter, Voltmeter, RPM meter, Oil Pressure Gauge, Temperature gauge, Hour Meter, Light Switches
Transportation & Handling	Hooks provided for lifting and hauling
Finish	Epoxy - Corrosion resistant ; Colour – As per customer choice
Material for Construction	Marine aluminum steel

Appendix - XIV

Function diagrams of hydraulic motors

MR 50 – Hydraulic motor

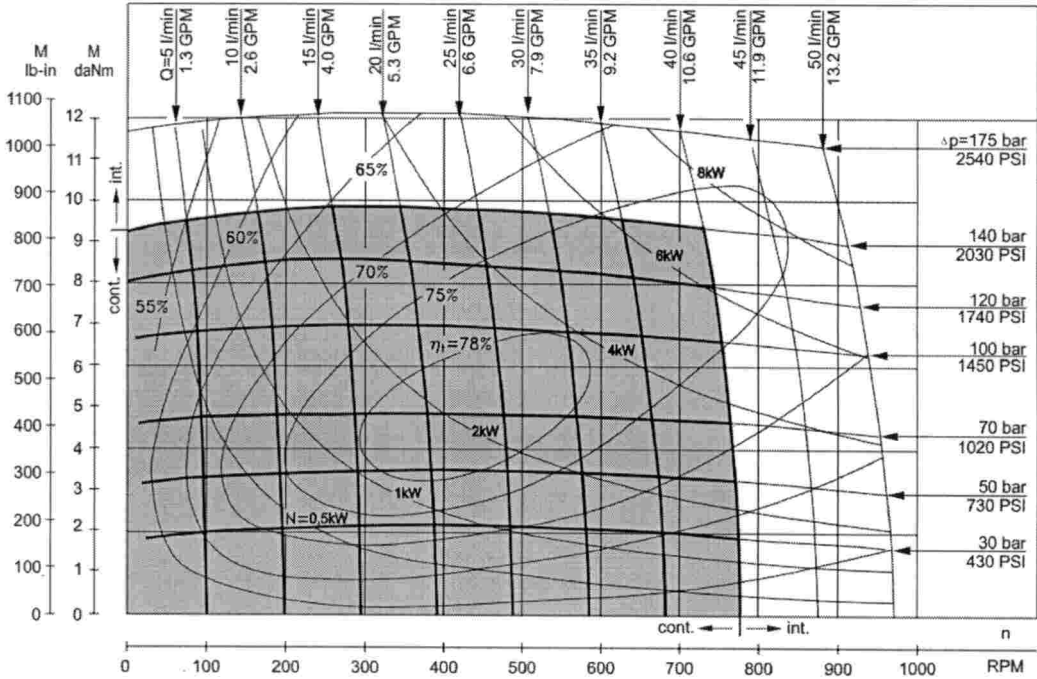

MAH 400 CB – Hydraulic motor

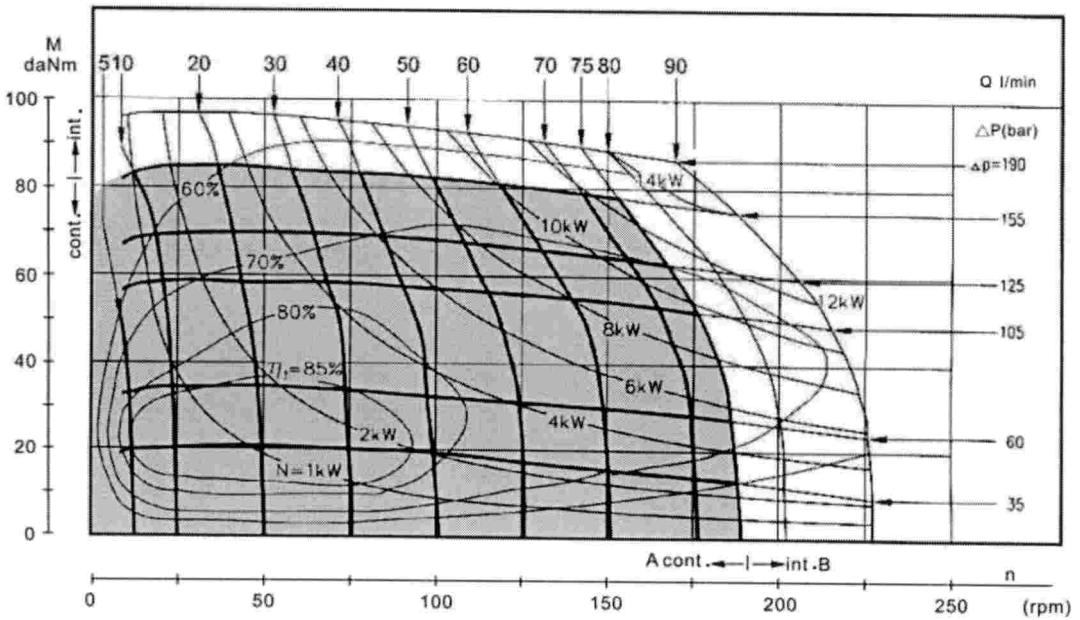

Power transmission circuit diagram of the Pokkali paddy harvester

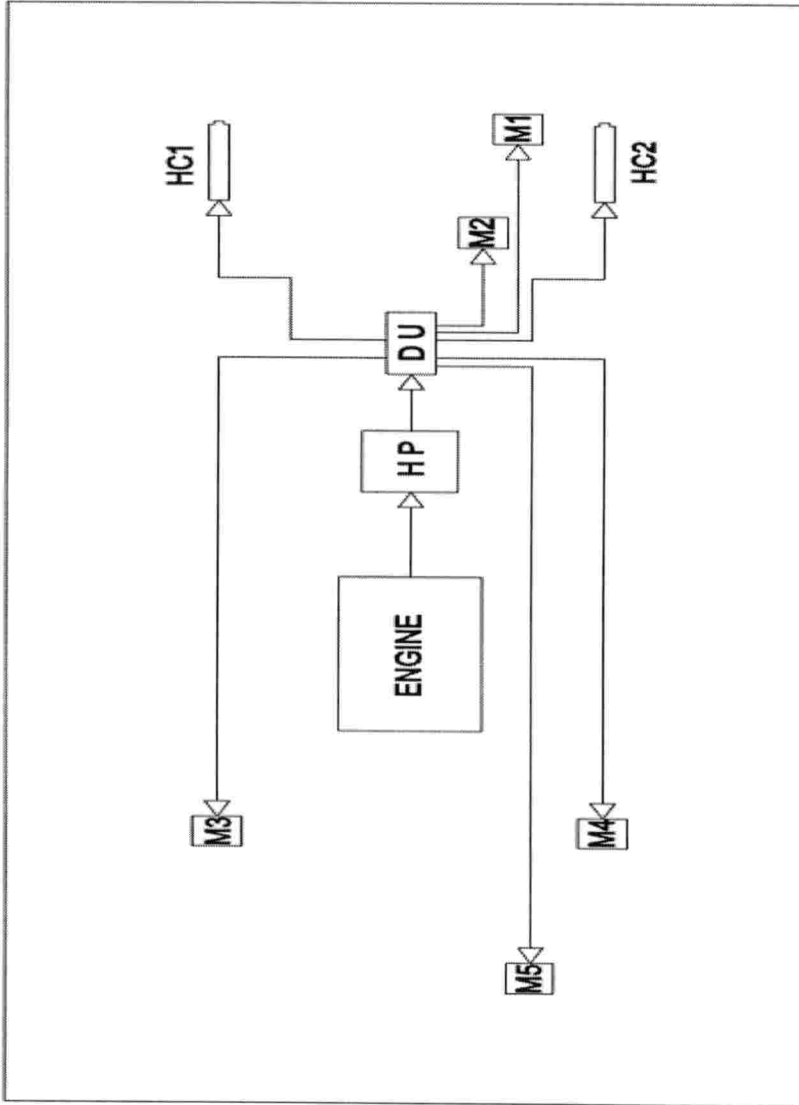

Particulars	Descriptions
HP	Hydraulic pump
DU	Distributor unit
M1	Hydraulic motor for cutter bar
M2	Hydraulic motor for front conveyor
M3	Hydraulic motor for left float
M4	Hydraulic motor for right float
M5	Hydraulic motor for centre conveyor
HC1	Hydraulic cylinder 1
HC2	Hydraulic cylinder 2

Appendix - XVI  
Components of existing KAU Pokkali paddy harvester

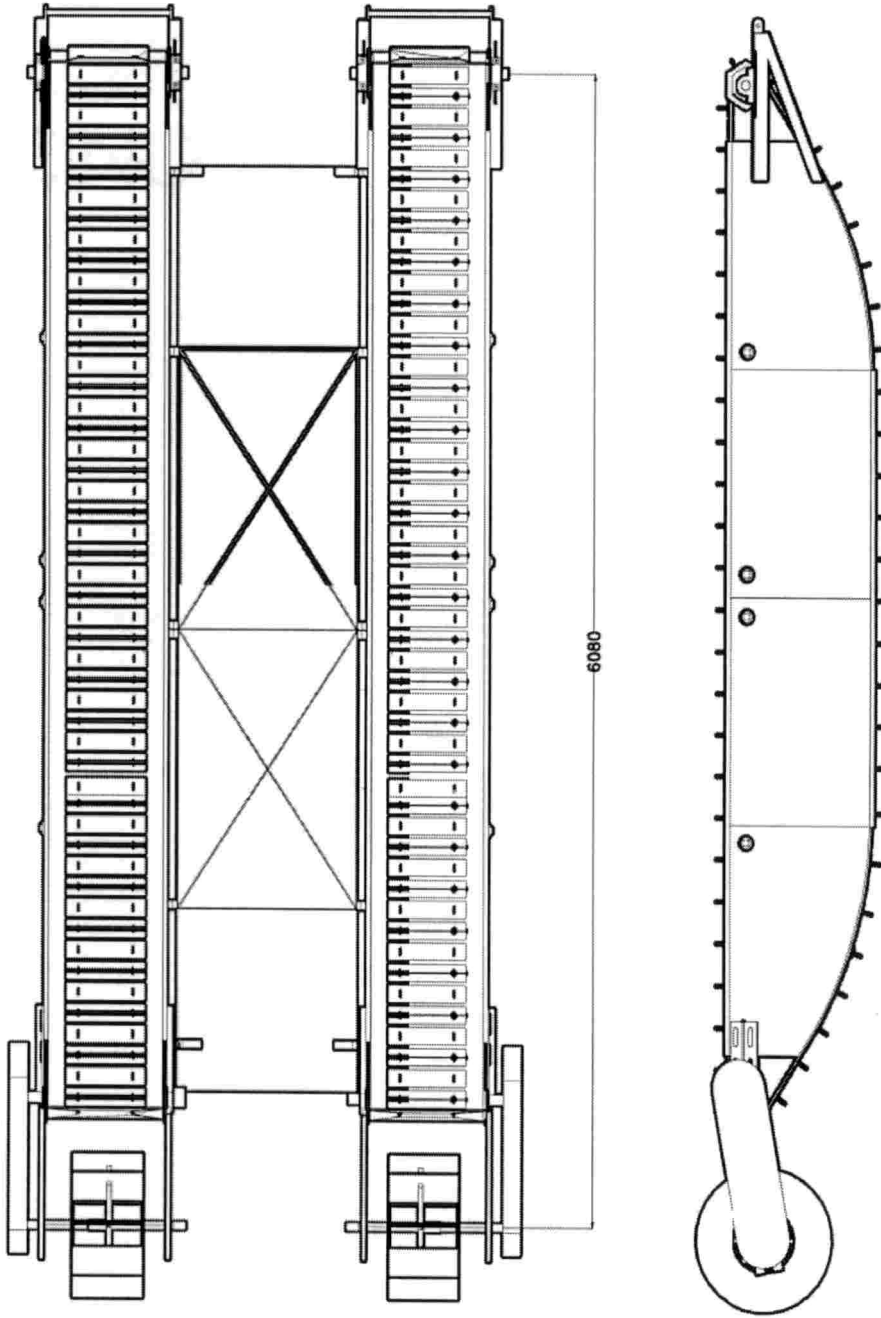

Fig. 1. Floats with propeller of the KAU Pokkali paddy harvester

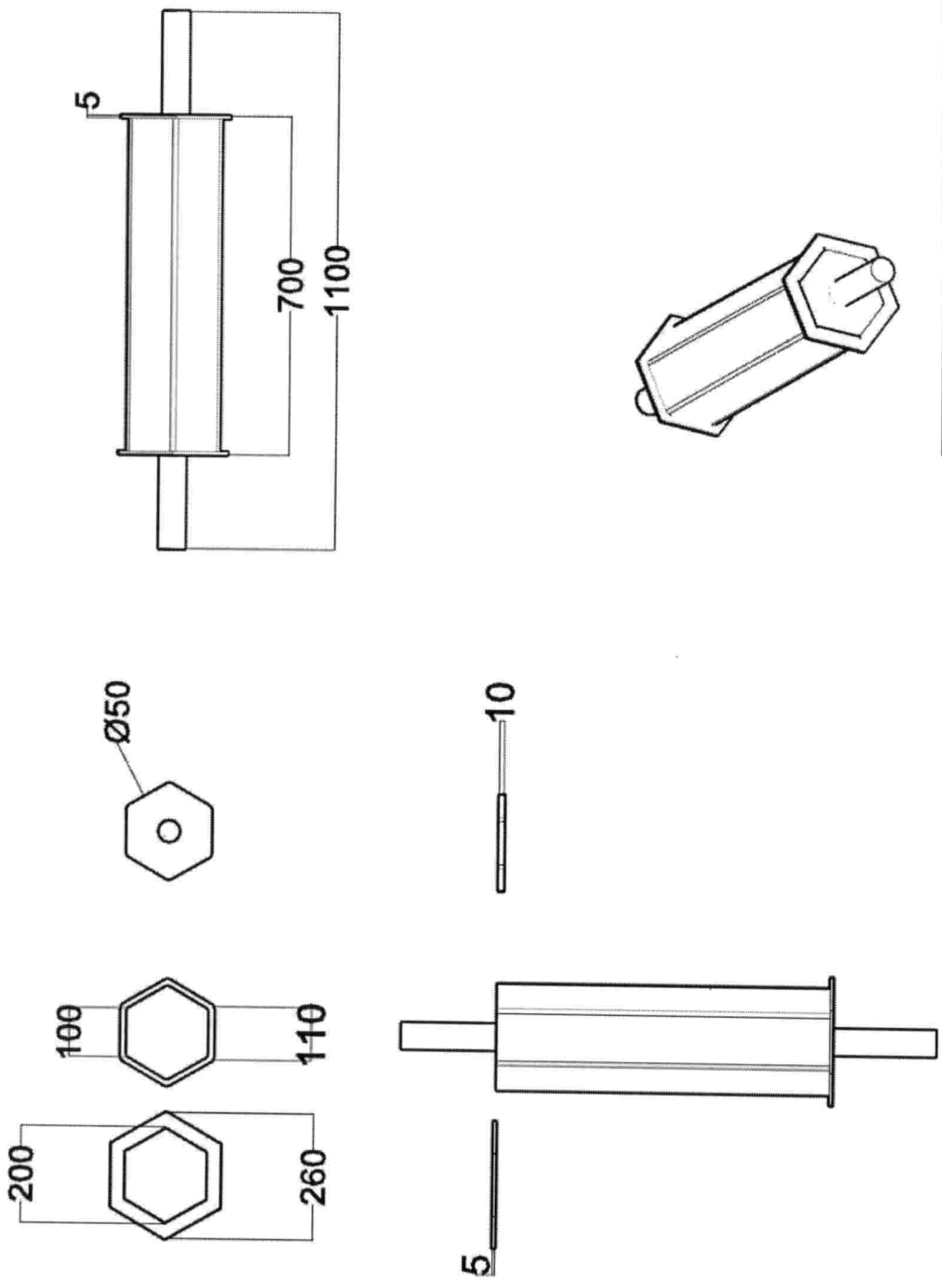

Fig. 2. Float roller of the KAU Pokklai paddy harvester

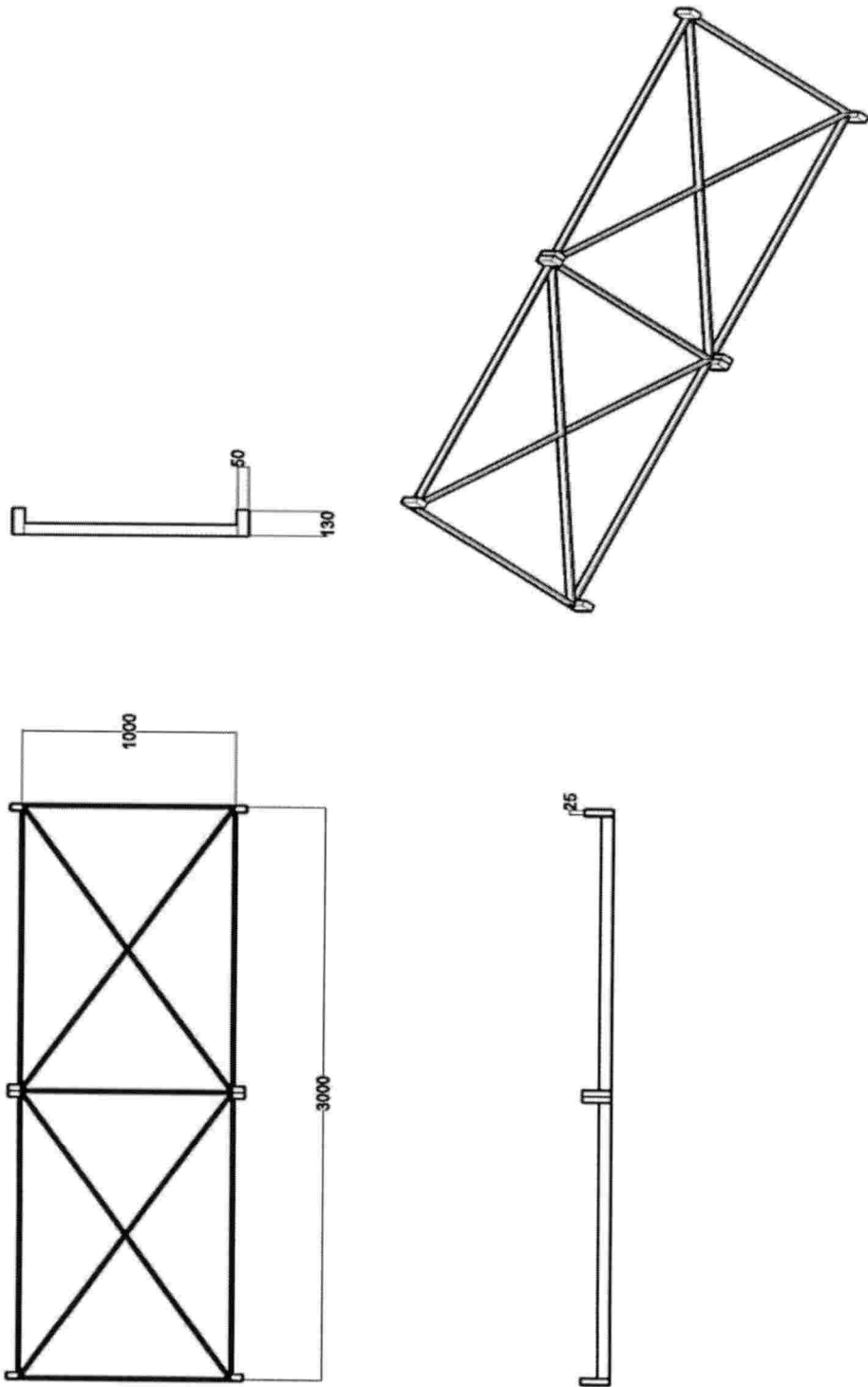

Fig. 3. Supporting frame for centre conveyor of the KAU Pokkali paddy harvester



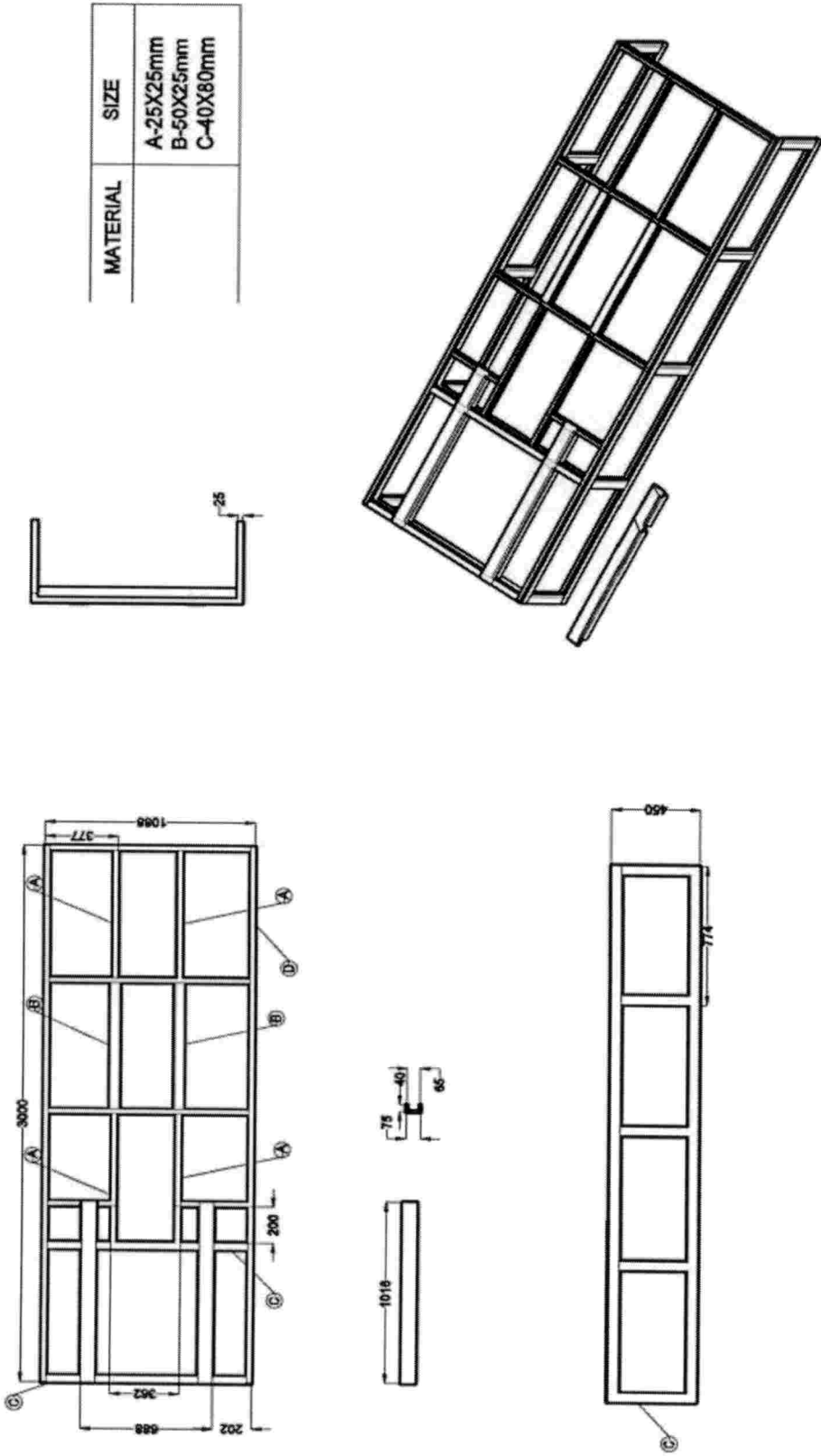

Fig. 4. Chassis of the KAU Pokkali paddy harvester

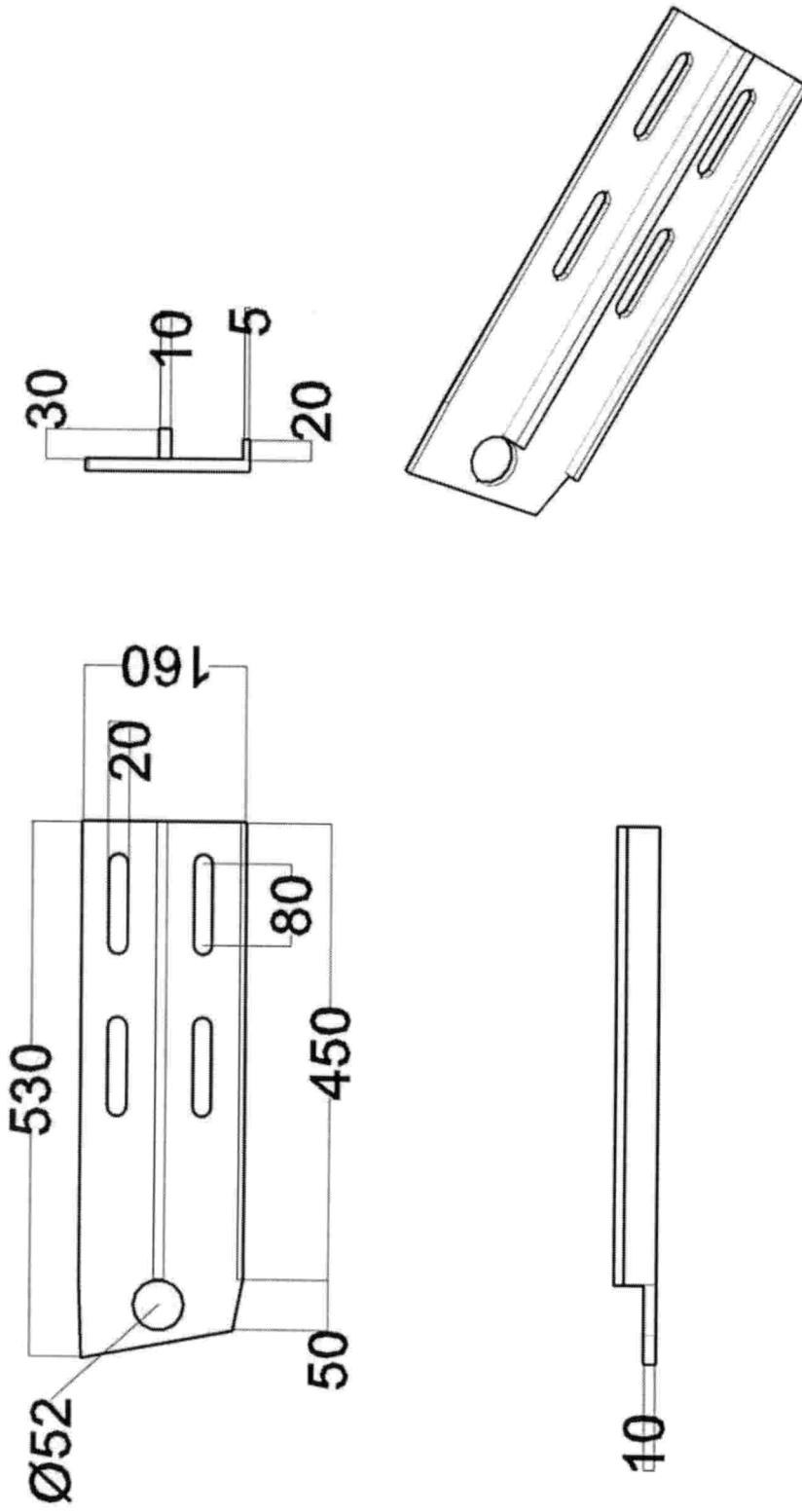

Fig. 5. Supporting plate for rollers and float

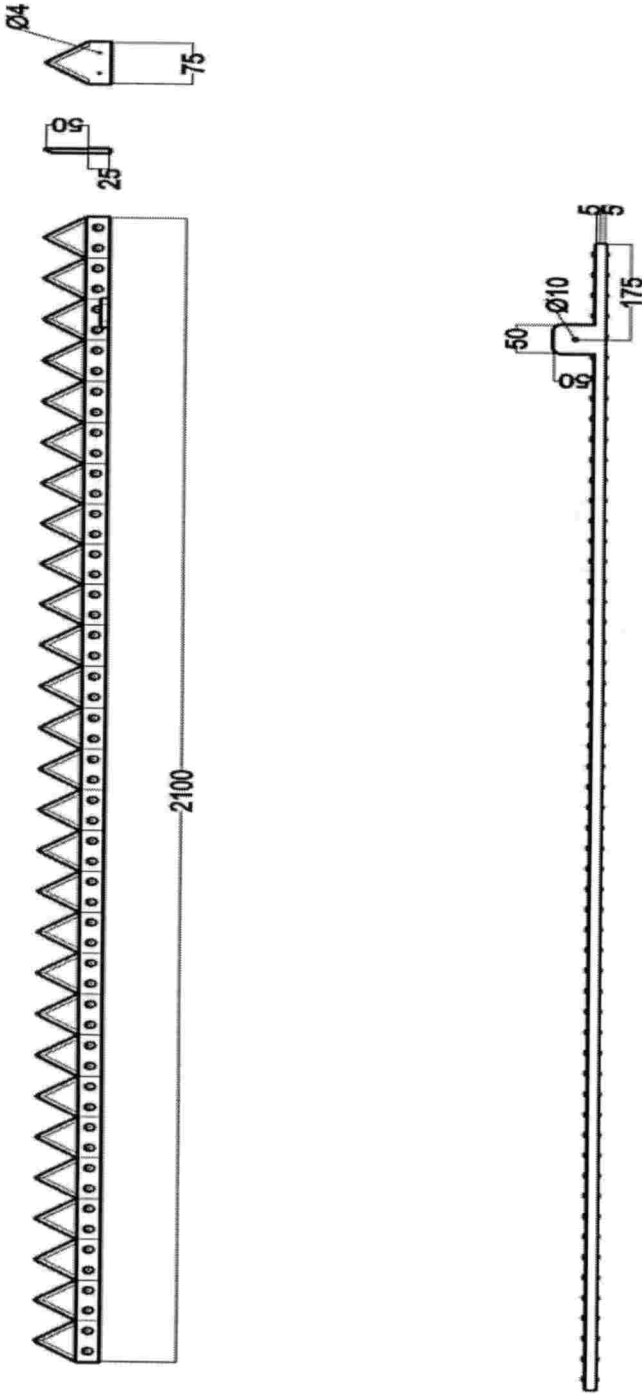

Fig. 6. Knife section of the KAU Pokkali paddy harvester

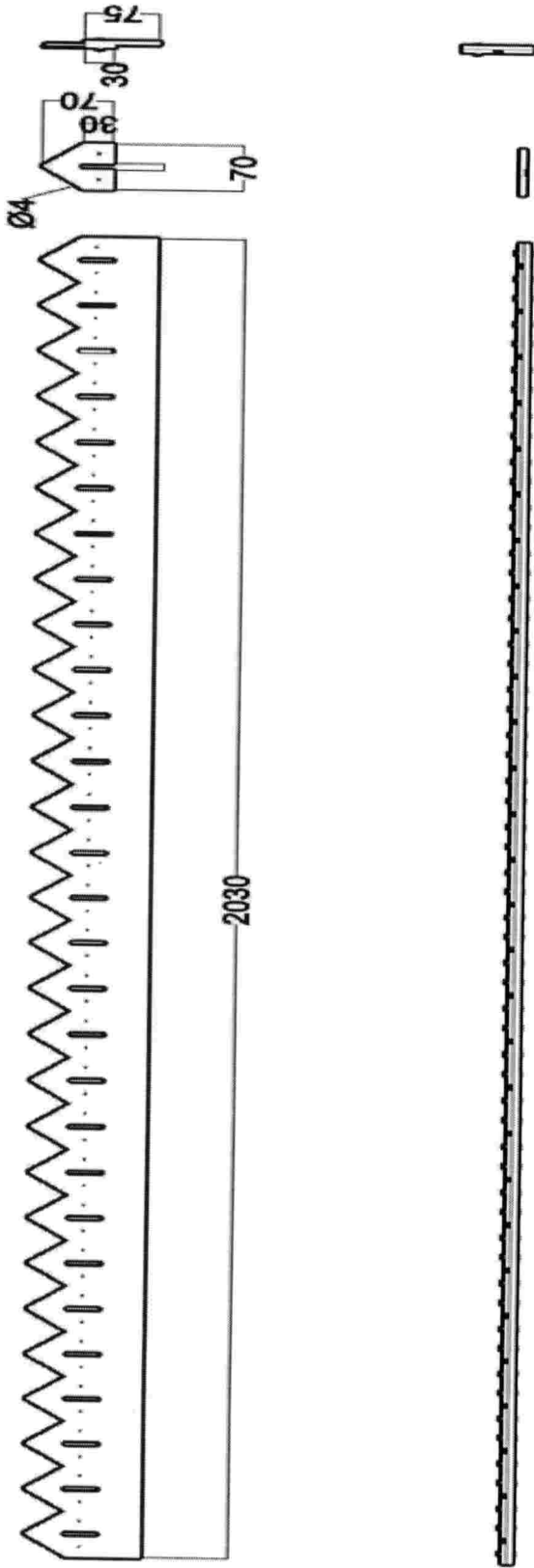

Fig. 7. Ledger plate of the KAU Pokkali paddy harvester

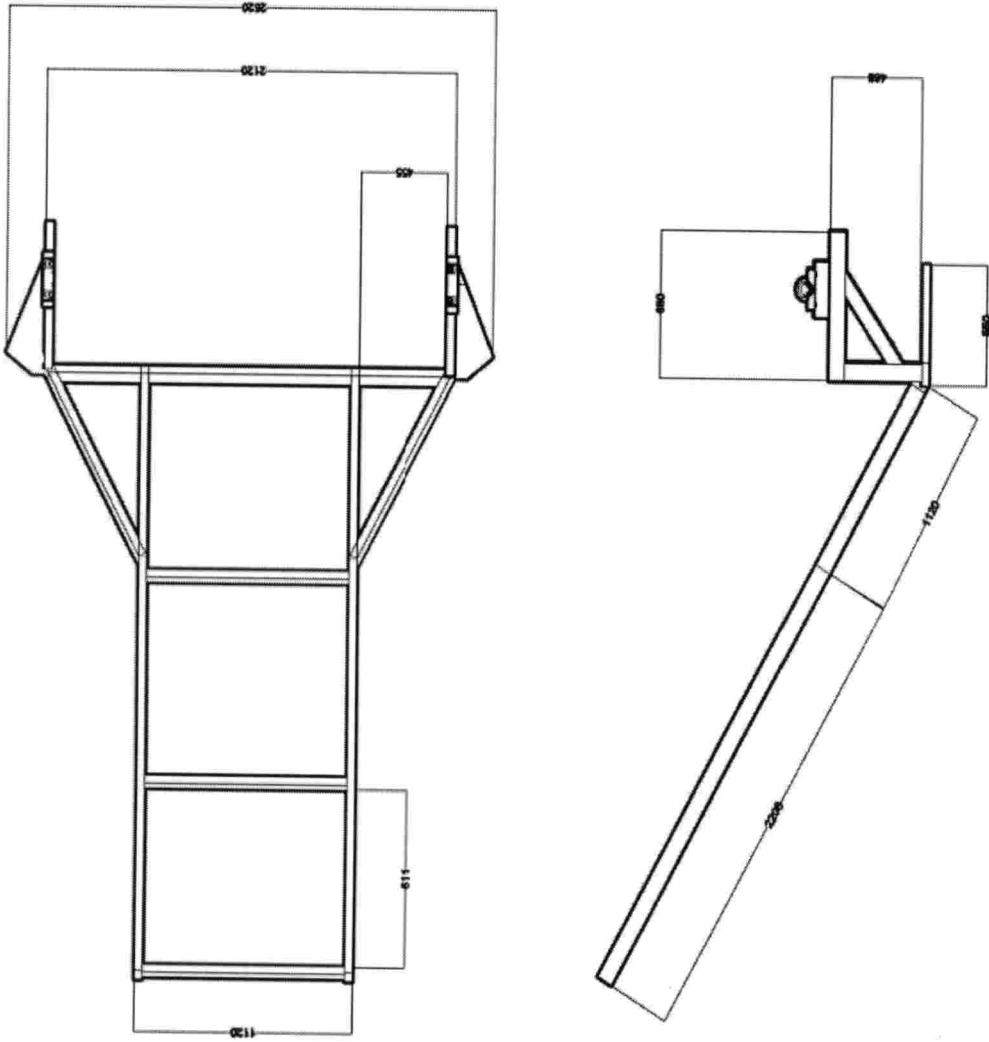

Fig. 8. Frame for Front conveyor, Reel and cutter bar of the KAU Pokkali paddy harvester

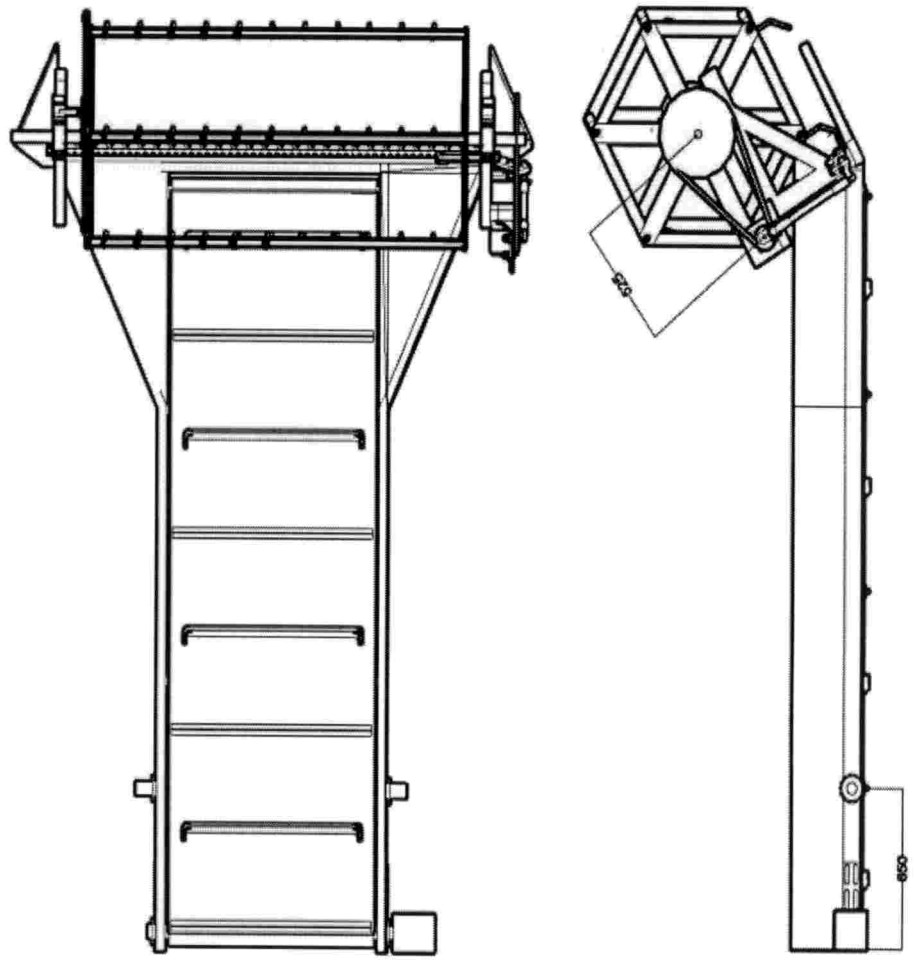

Fig. 9. Front conveyor with Reel and cutter bar assembly of the KAU Pokkali paddy harvester

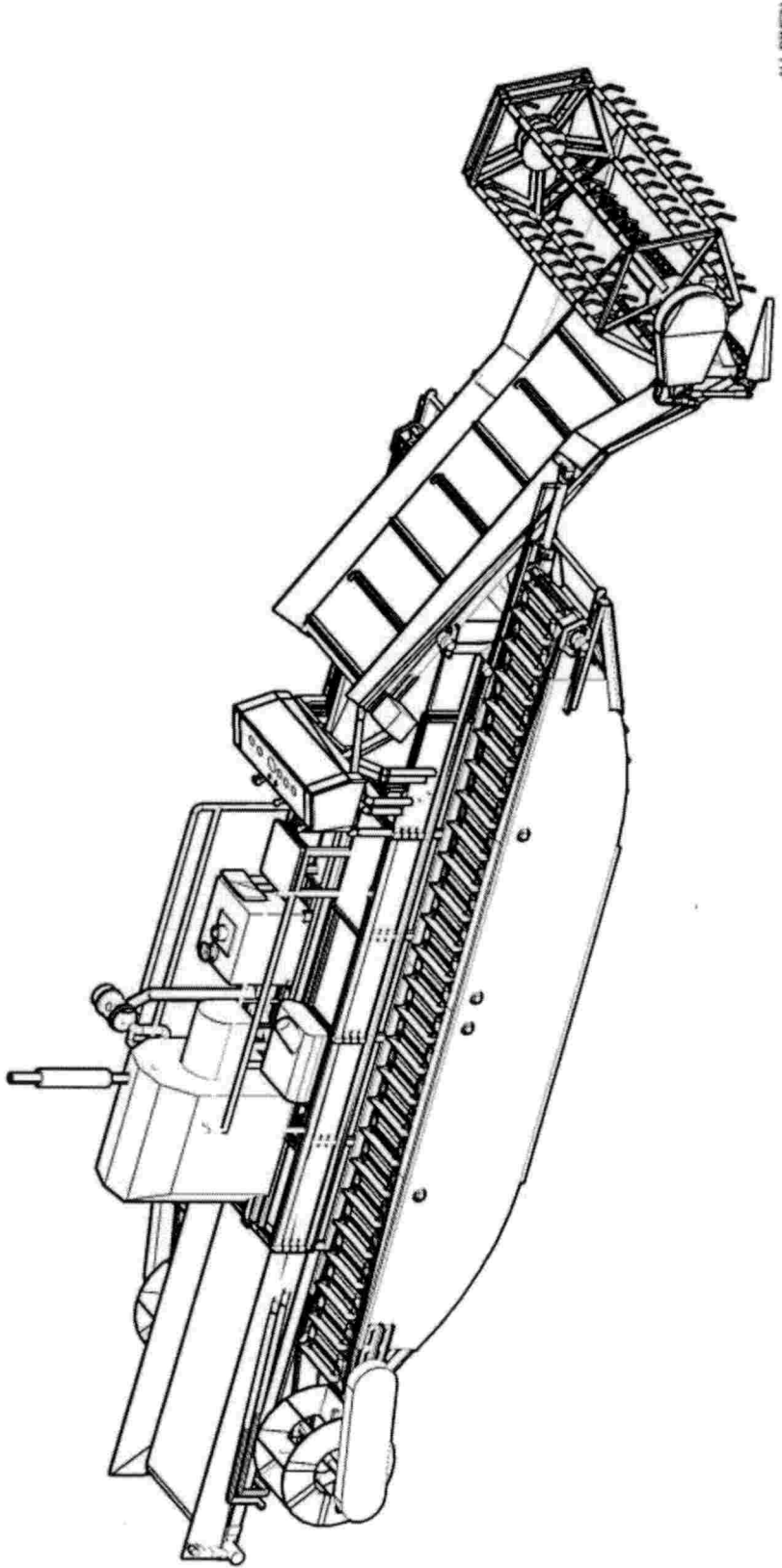

Fig. 10 Isometric view of the KAU Pokkali paddy harvester

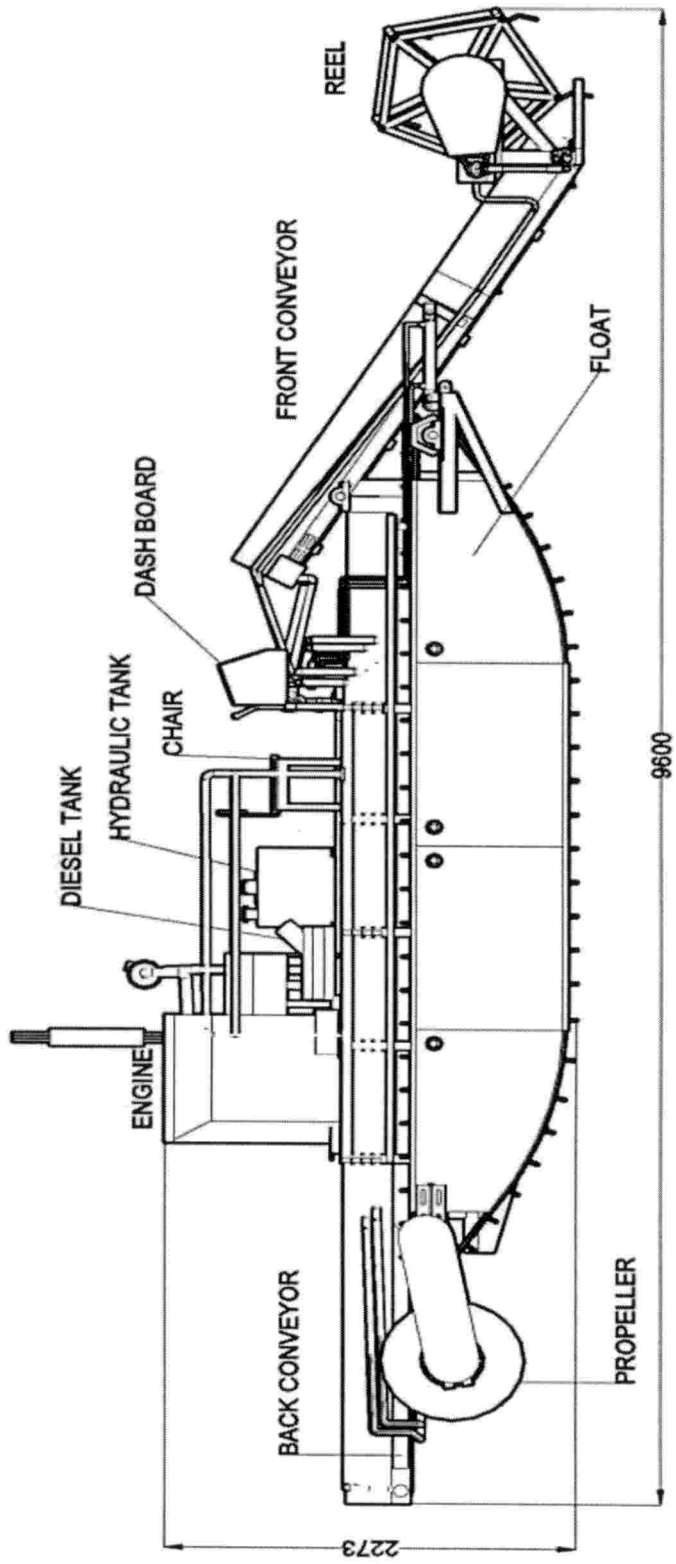

Fig. 11 Elevation view of the KAU Pokkali paddy harvester



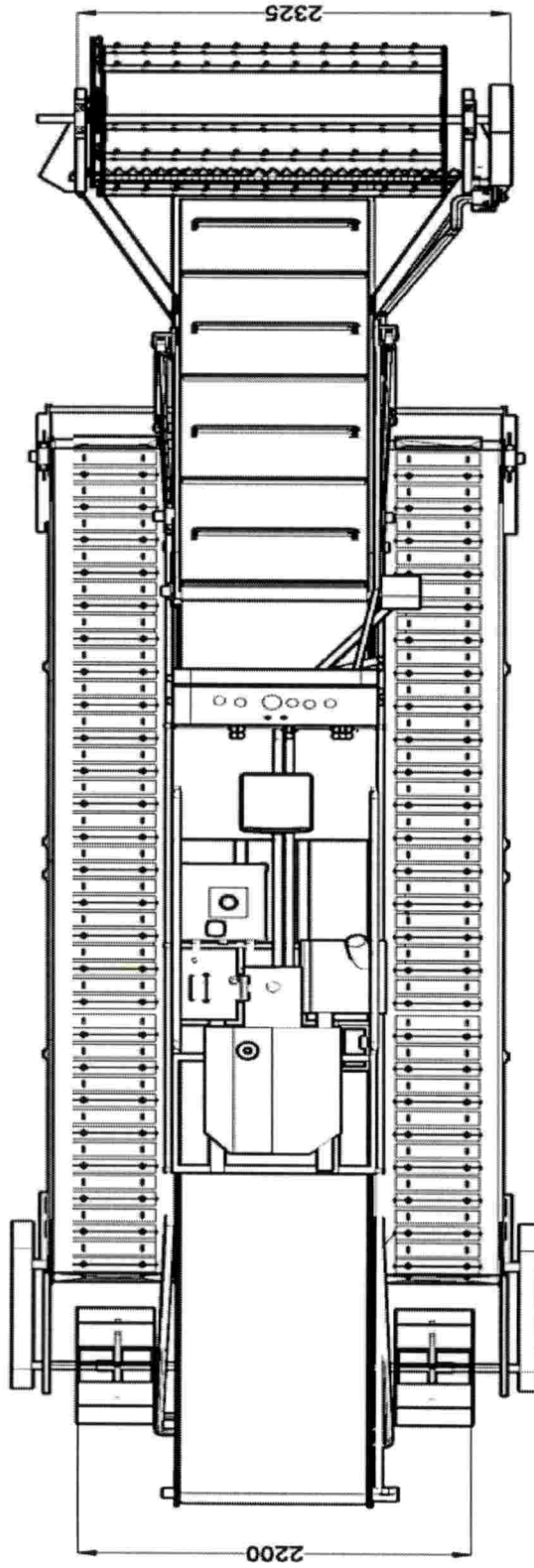

Fig. 12 Plan view of the KAU Pokkali paddy harvester

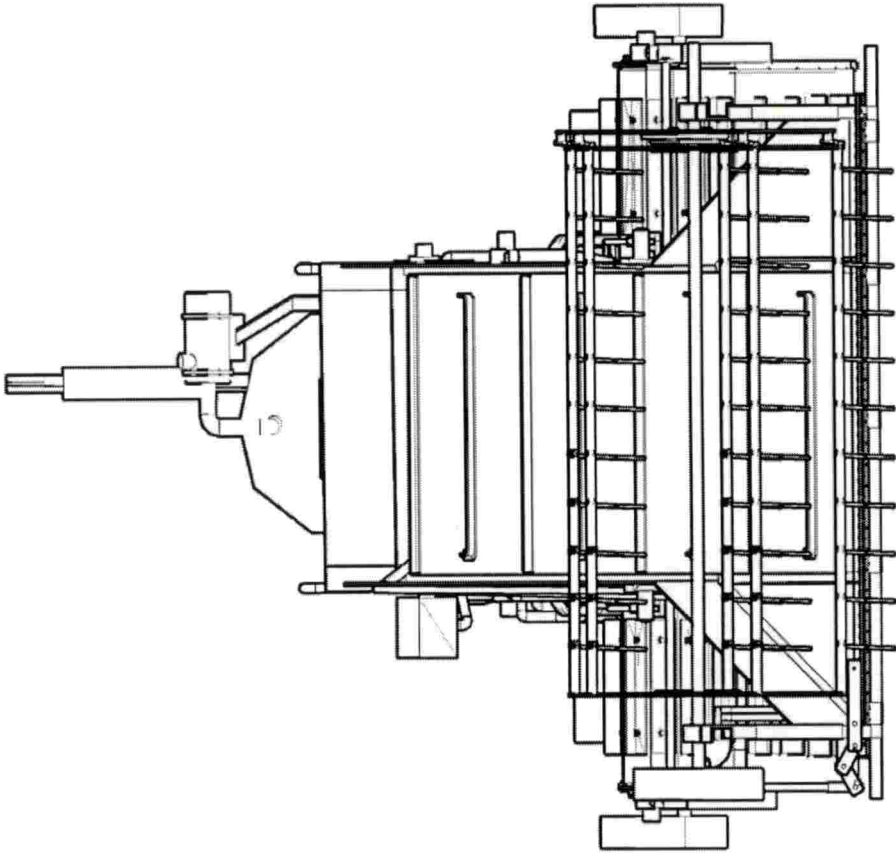

Fig. 13. Front view of the KAU Pokkali paddy harvester

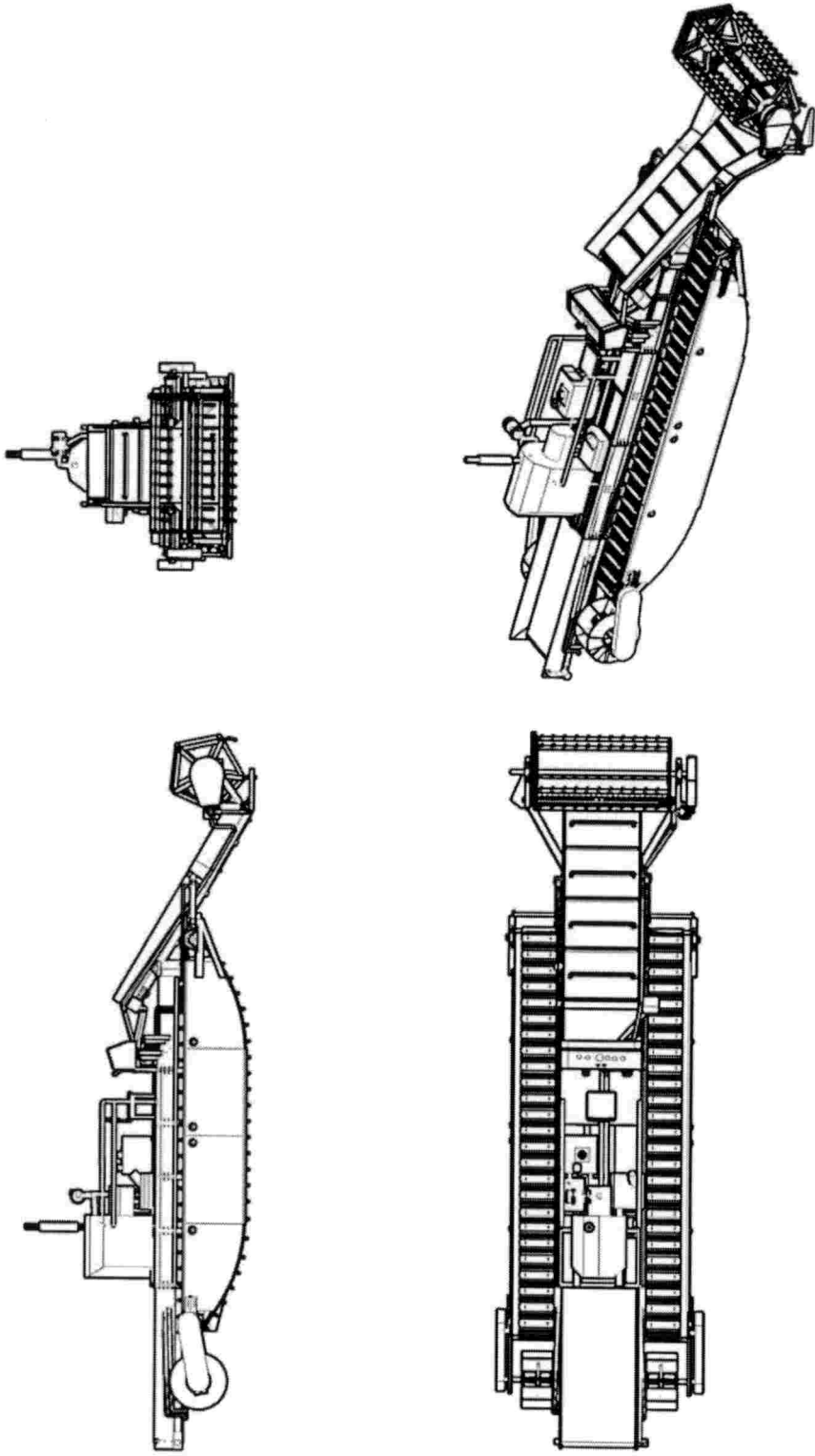

Fig. 14. Orthographic view of the KAU Pokkali paddy harvester

## Appendix - XVII

## Components of scale down prototype of Pokkali paddy harvester

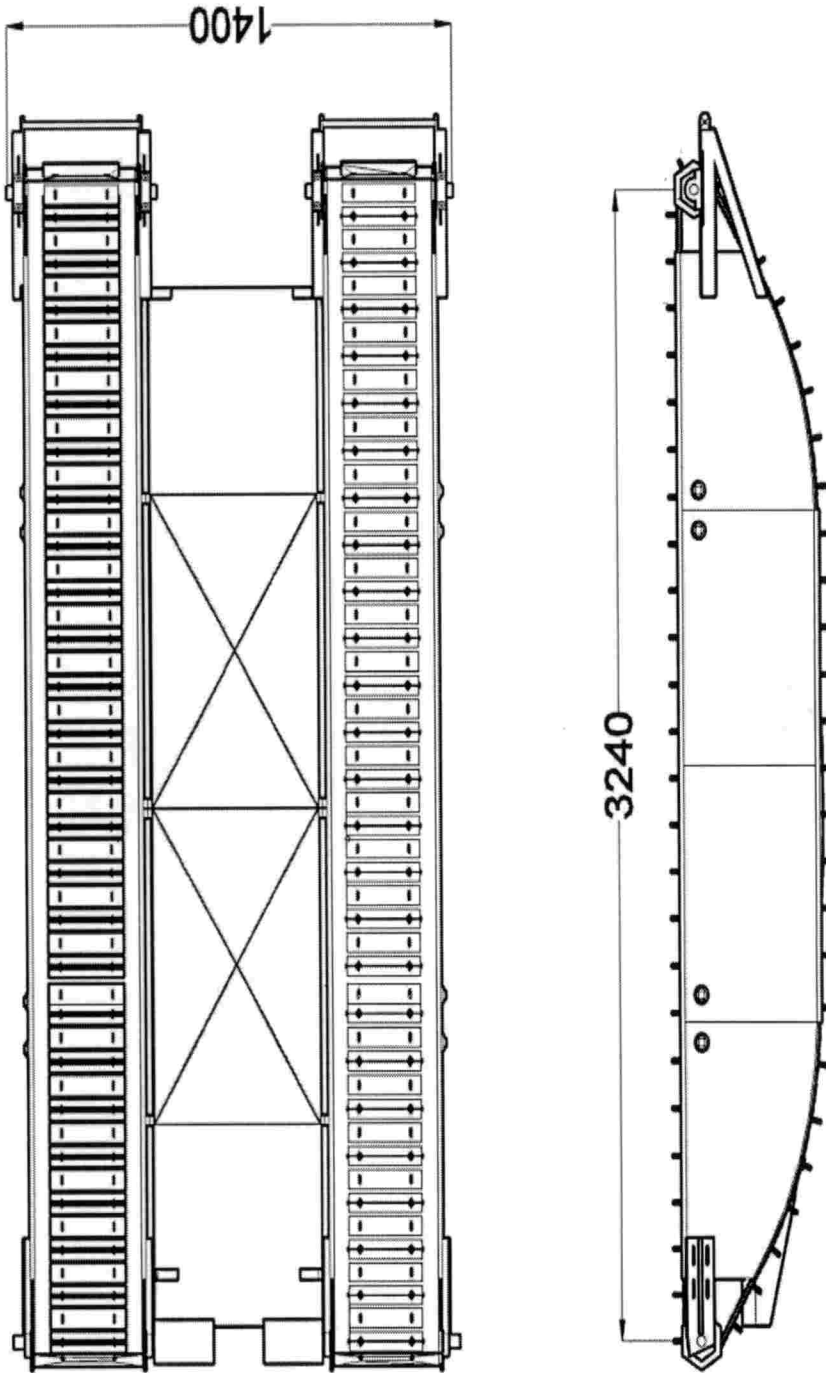

Fig. 1. Floats with propeller of the scale down Pokkali paddy harvester

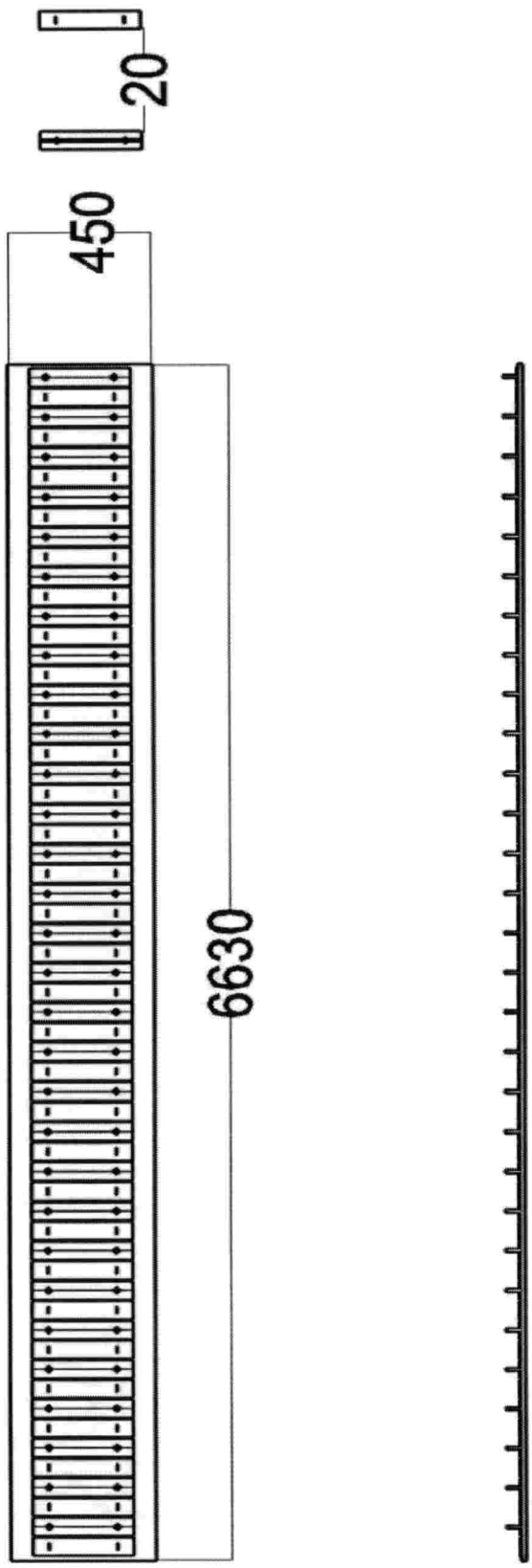

Fig. 2. Traction belt of the scale down Pokkali paddy harvester

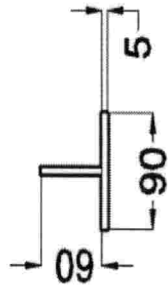
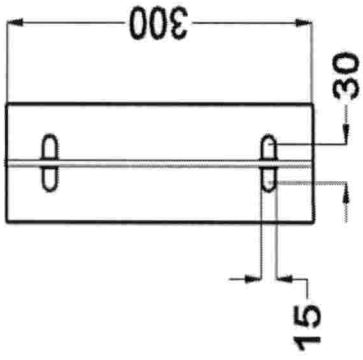
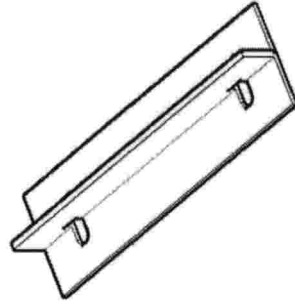
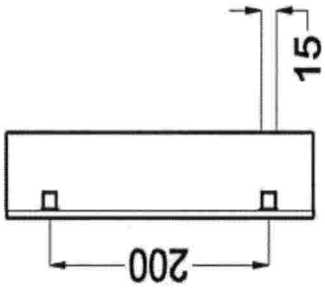

Fig. 3. Grouser of the scale down Pokkali paddy harvester

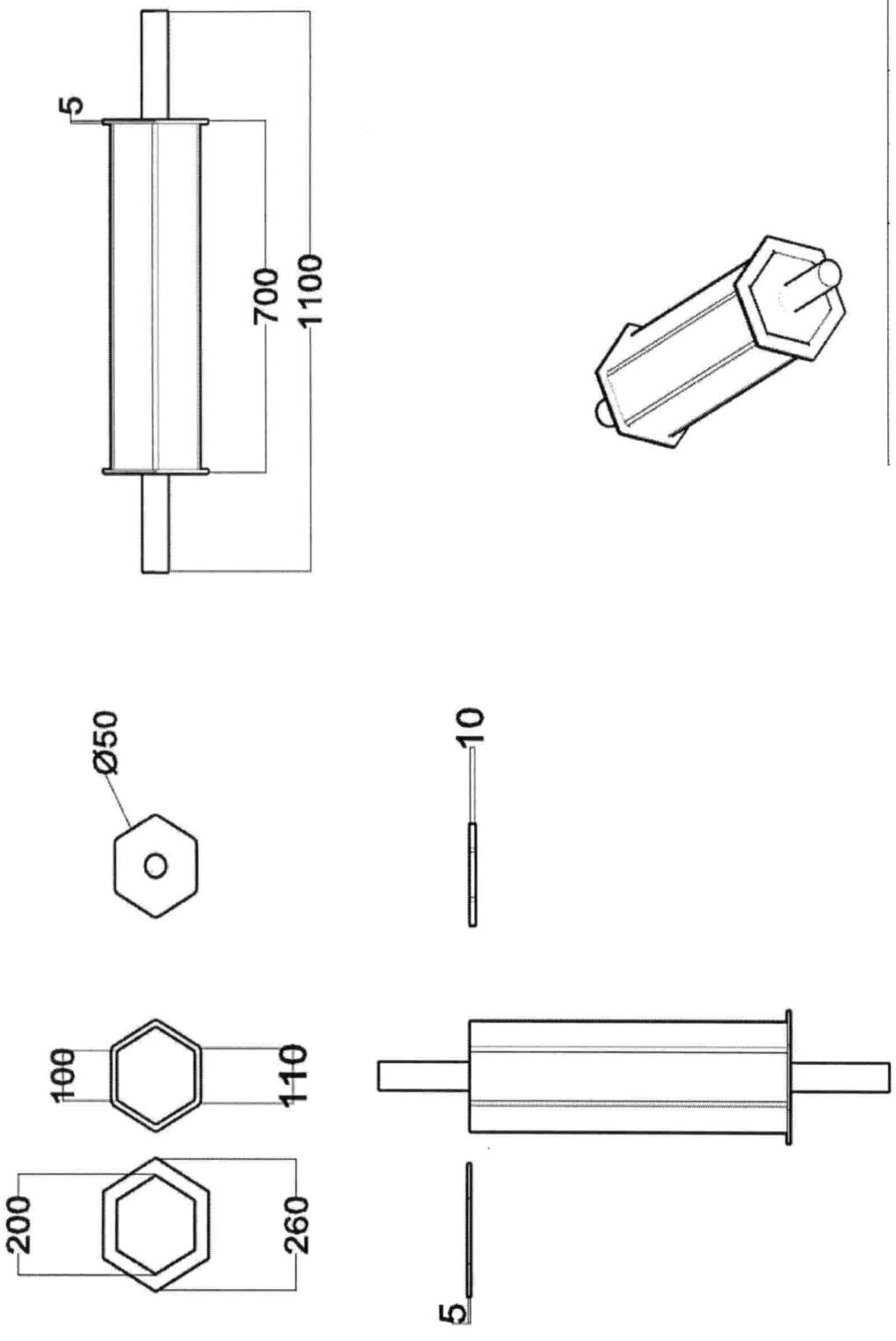

Fig. 4. Float roller of the scale down Pokklai paddy harvester

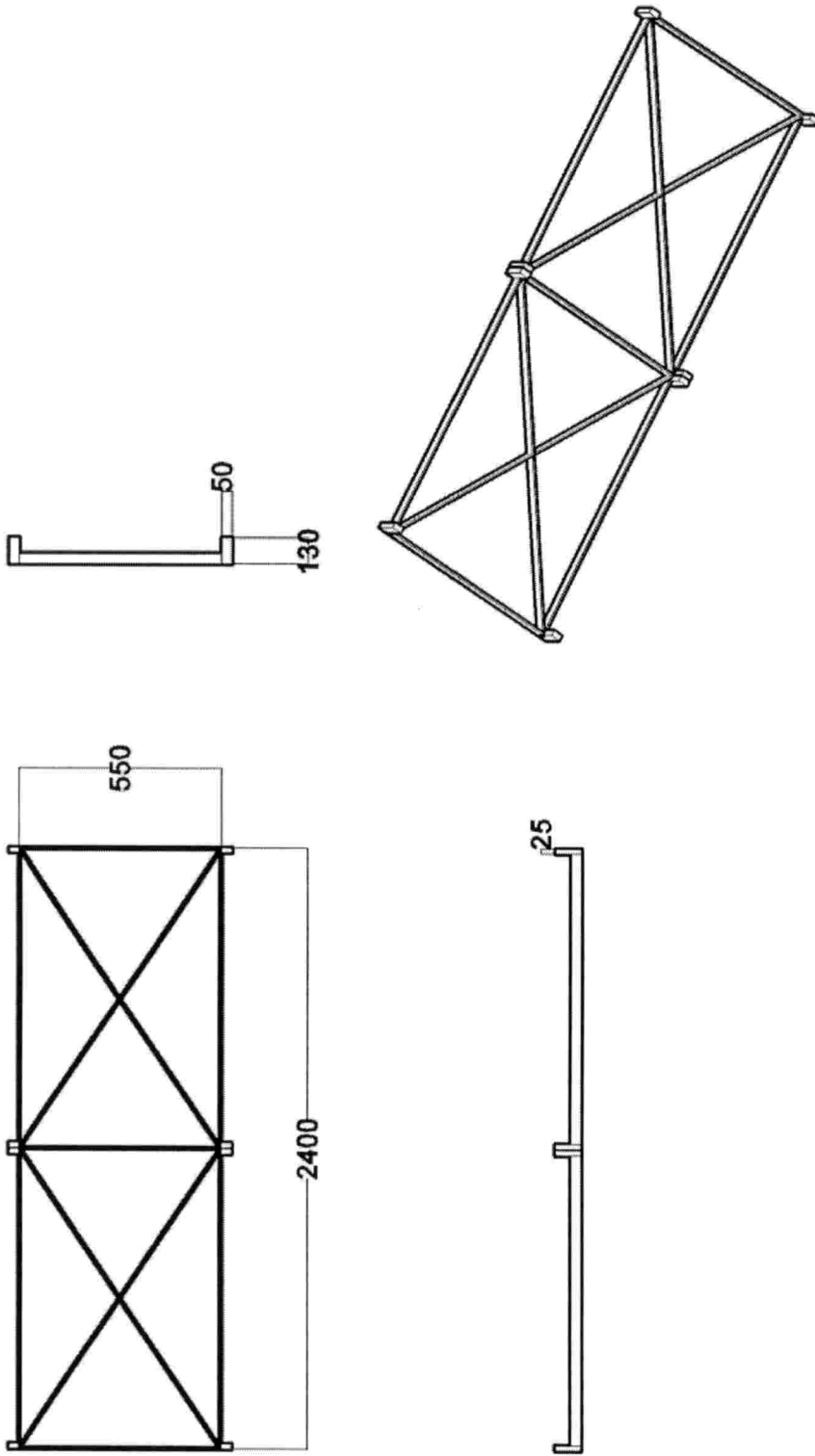

Fig. 5. Supporting frame for centre conveyor of the scale down Pokkali paddy harvester



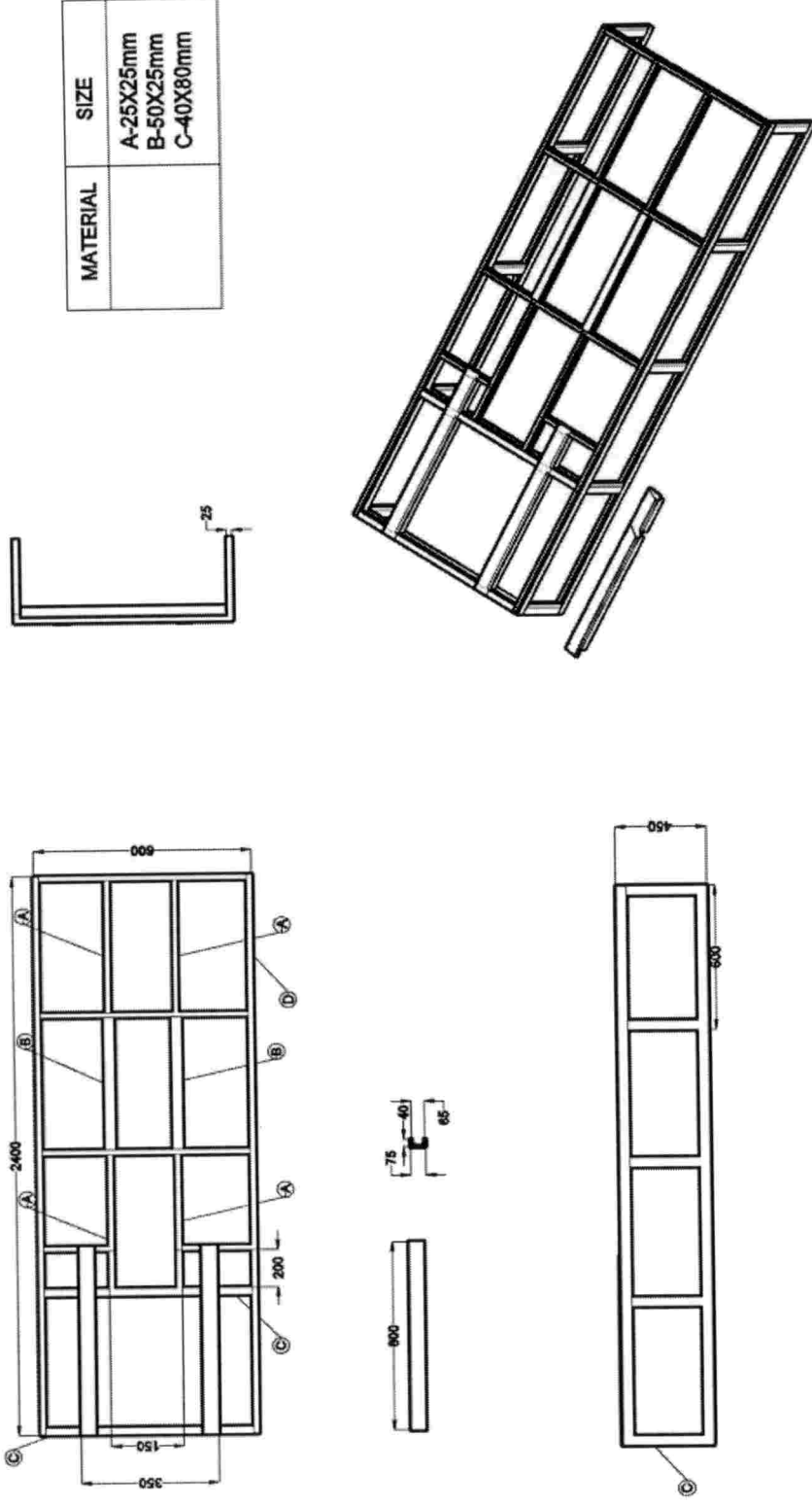

Fig. 6. Chassis of the scale down Pokkali paddy harvester

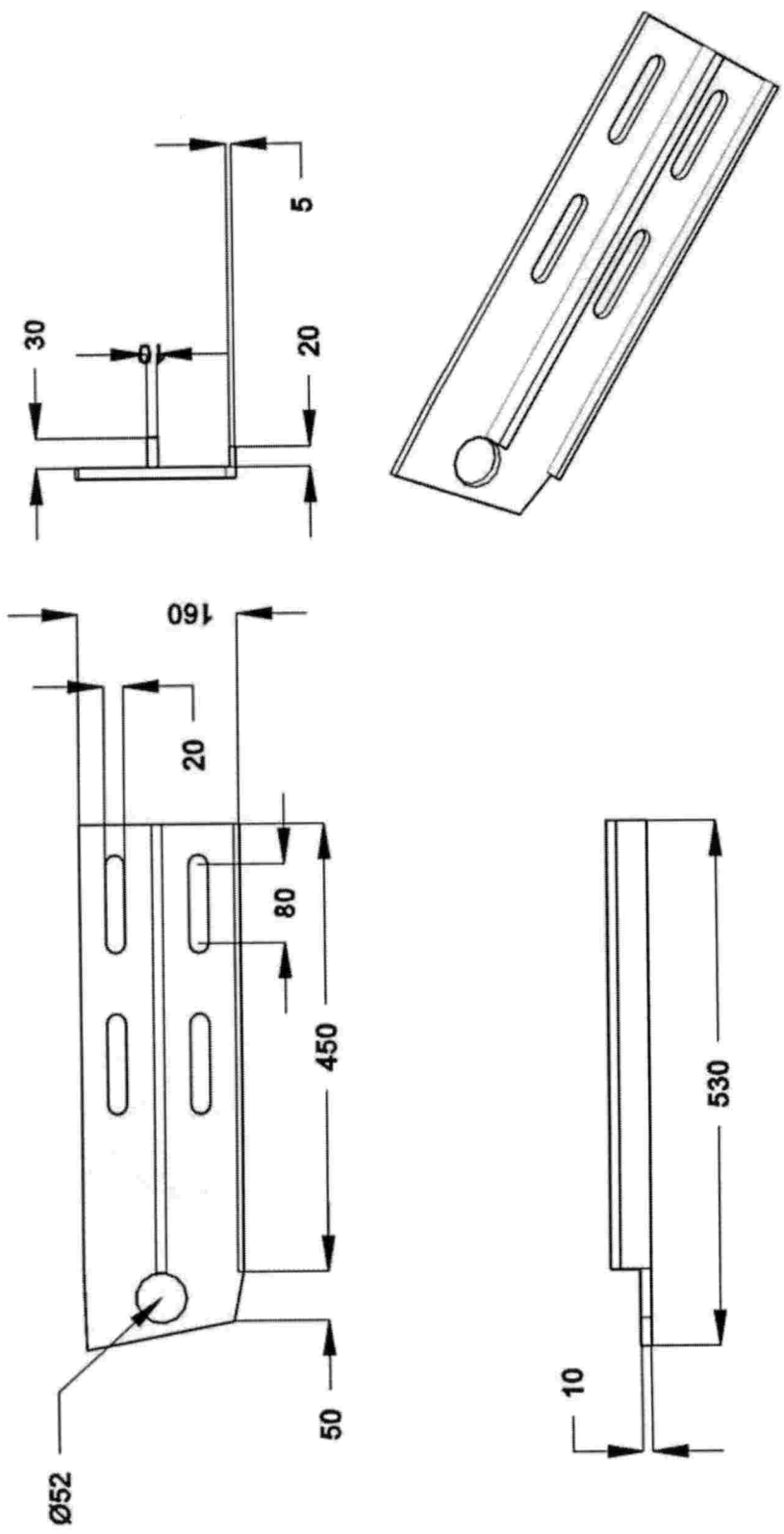

Fig. 7. Supporting plate for rollers and float

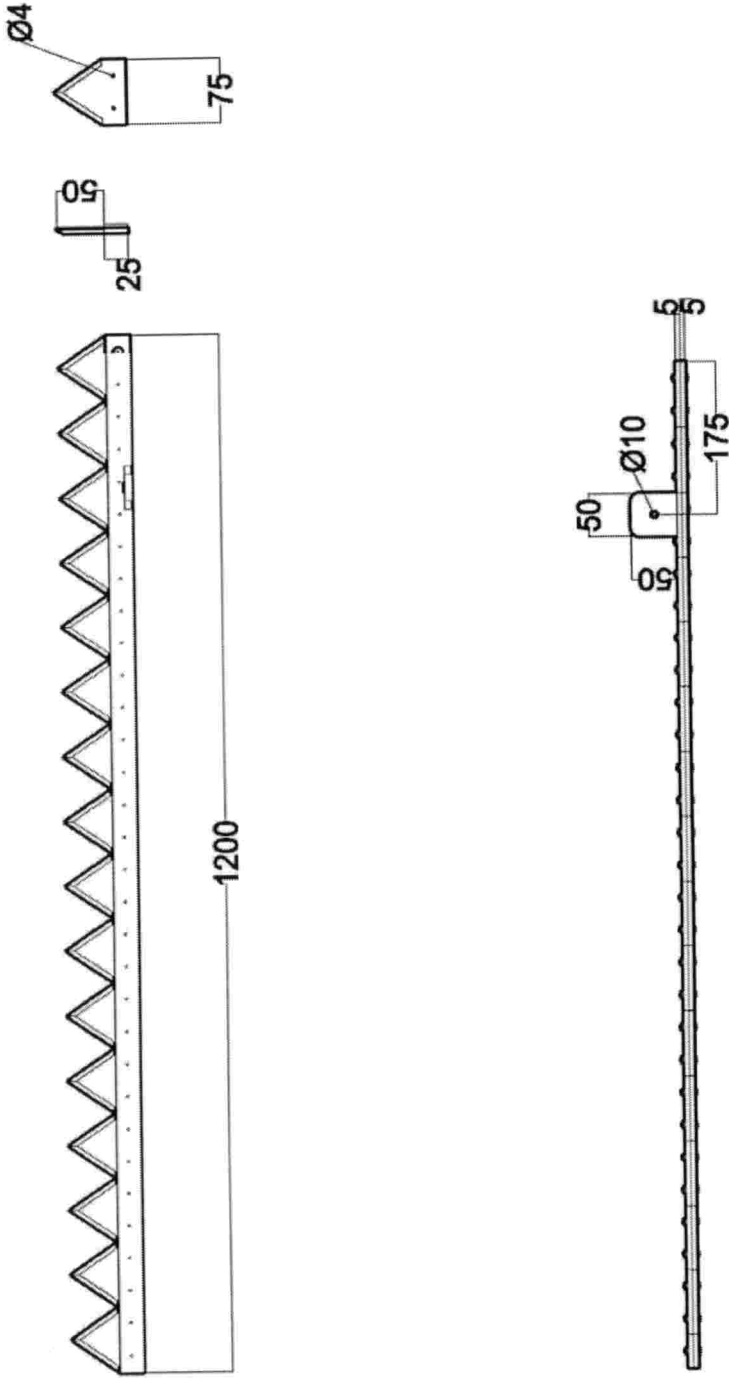

Fig. 8 Knife section of the scale down Pokkali paddy harvester

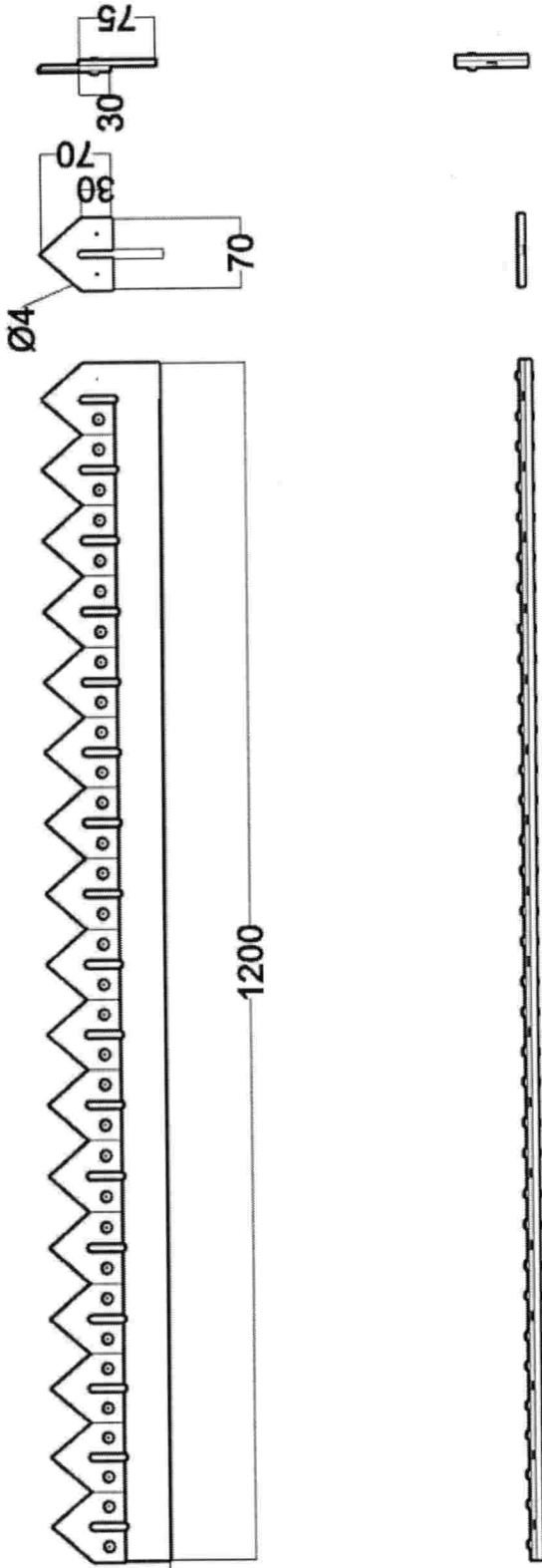

Fig. 9. Ledger plate of the scale down Pokkali paddy harvester

107

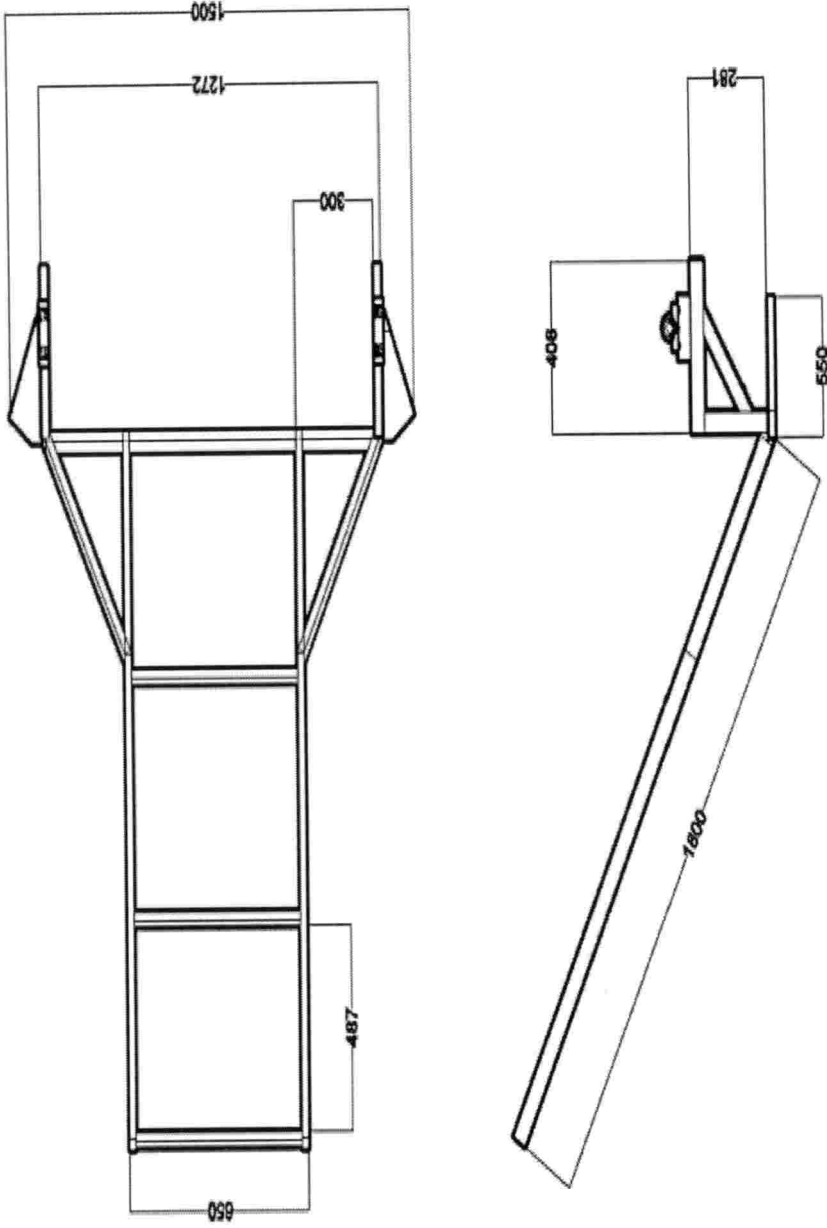

Fig. 10. Frame for Front conveyor, Reel and cutter bar of the scale down Pokkali paddy harvester

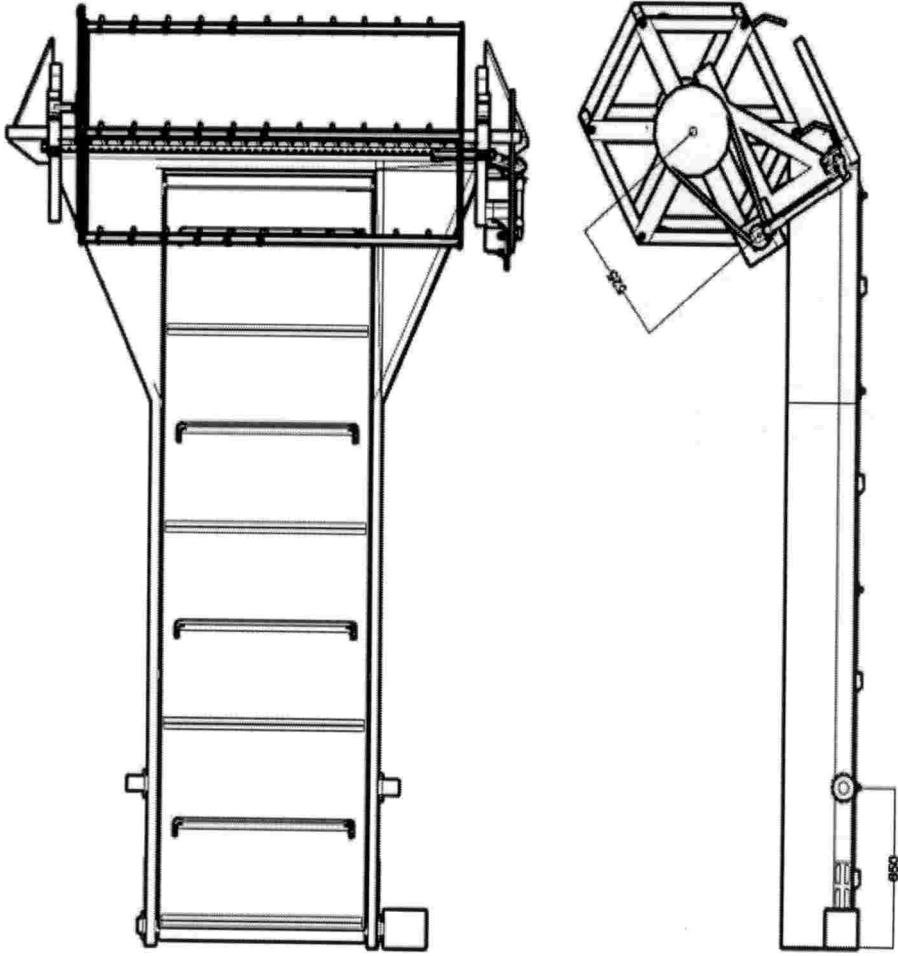

Fig. 11. Front conveyor with Reel and cutter bar assembly of the scale  
down Pokkali paddy harvester

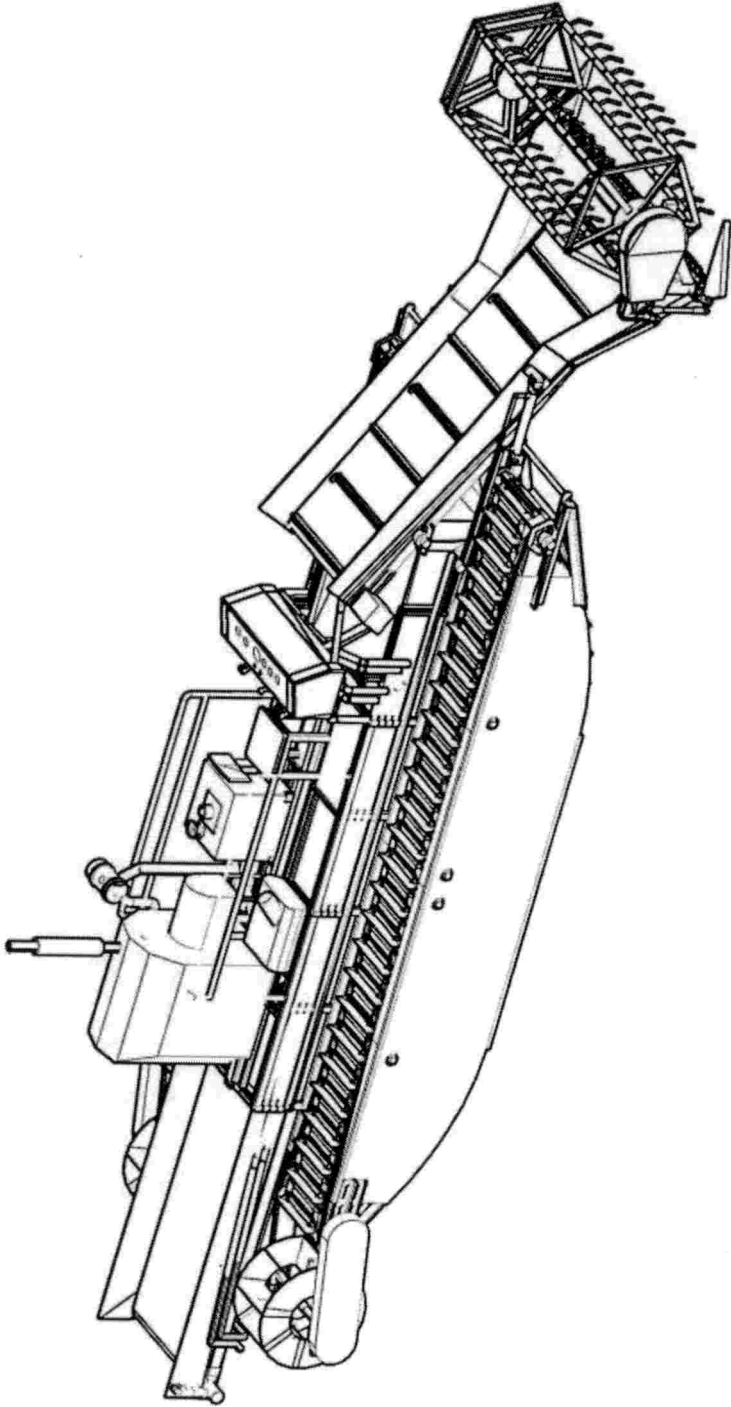

Fig. 12 Isometric view of the scale down Pokkali paddy harvester

172

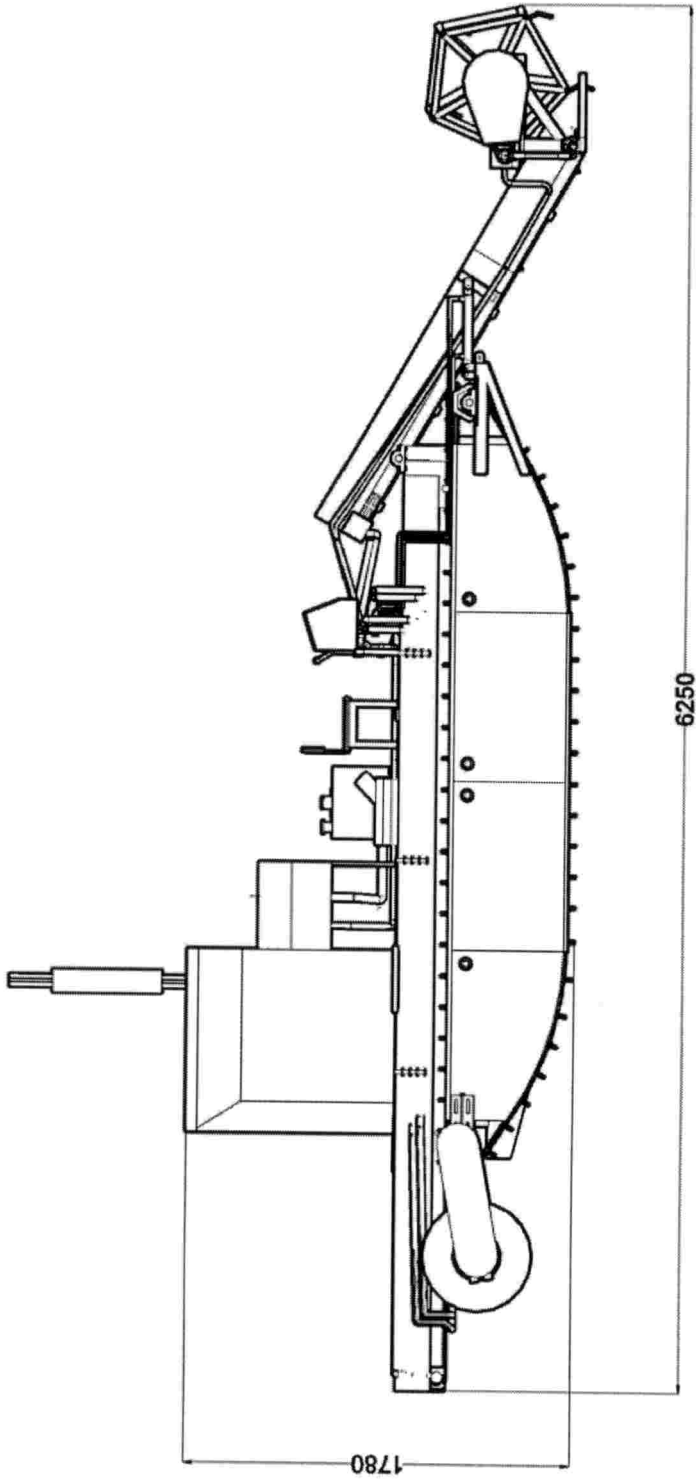

Fig. 13 Elevation view of the scale down Pokkali paddy harvester



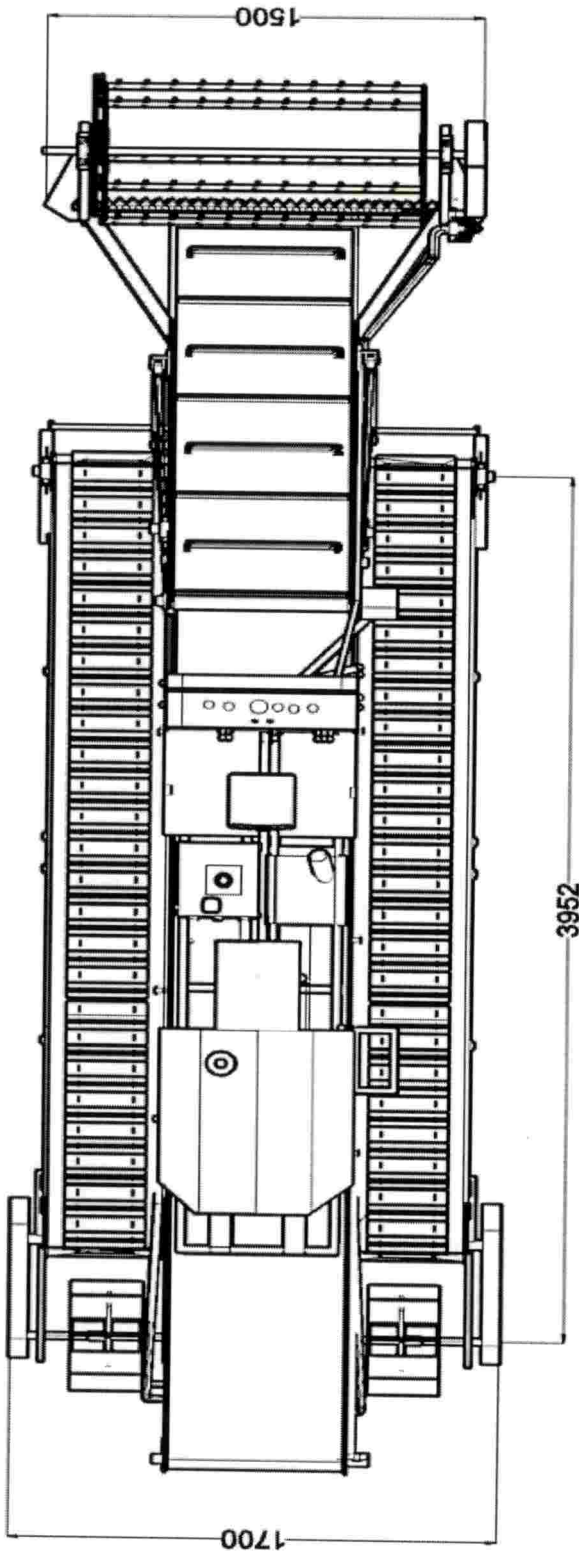

Fig. 14 Plan view of the scale down Pokkali paddy harvester

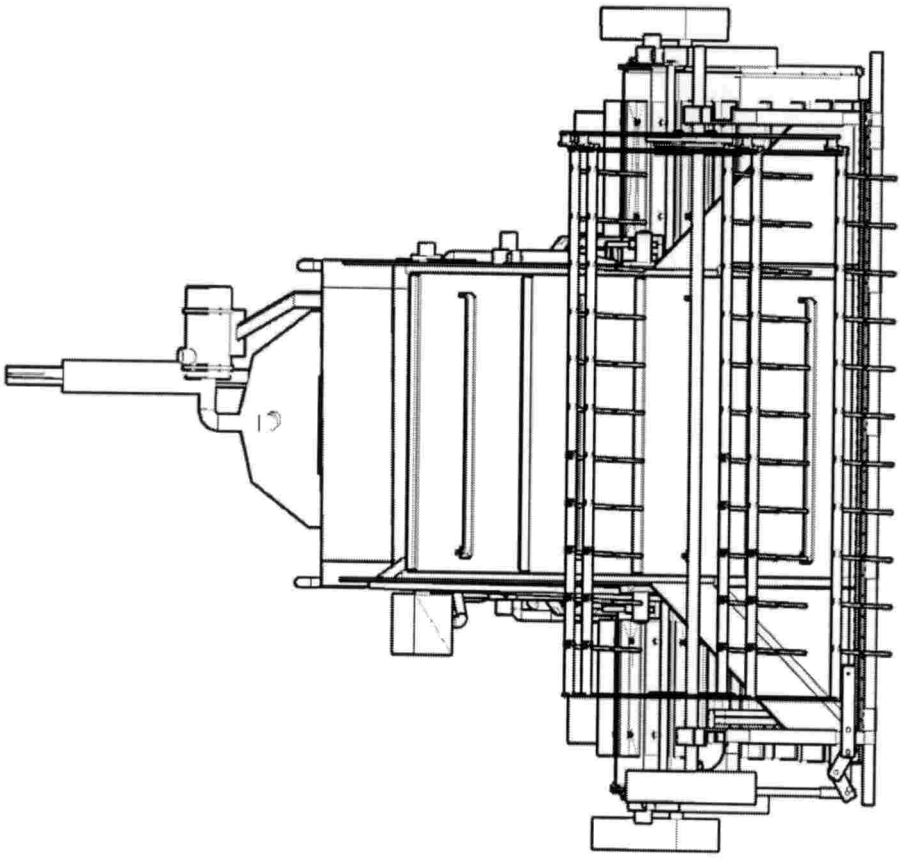

Fig. 15. Front view of the scale down Pokkali paddy harvester

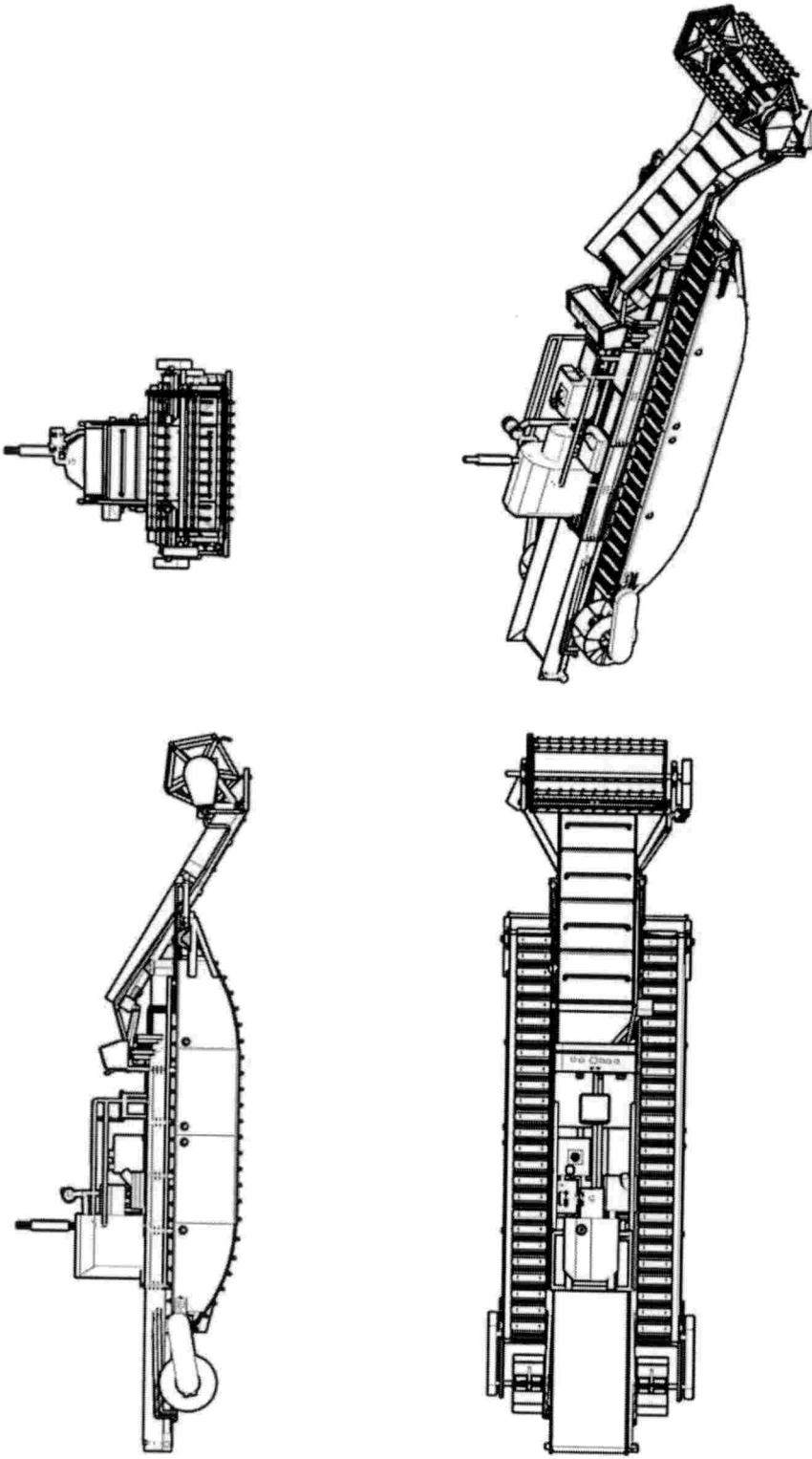

Fig. 16. Orthographic view of the scale down Pokkali paddy harvester

## Appendix - XVIII

## Cost estimation of the scale down Pokkali paddy harvester

Sl. No	Items	Quantity	Cost (Rs. in lakhs)
1	Engine (24 hp)	1 No	5.00
2	Floats	2 No's	0.50
3	Air chamber	1 No	0.30
4	Track belt and its accessories	2 No's	2.00
5	Propeller with chain drive	2 Sets	0.30
6	Hydraulic system		
	(i) Motors	5 No's	2.00
	(ii) Cylinders	2 No's	0.40
	(iii) Tank	1 No	0.10
	(iv) Hydraulic hose	15 m	0.15
	(v) Control levers	5 Sets	0.25
7	Conveyors	2 No's	0.50
8	Cutter bar and reel assembly	1 Set	1.5
9	Chassis	1 No's	1.00
10	Miscellaneous		2.00
	<b>TOTAL</b>		<b>16.00</b>

Total cost for material, Rs = 16.00 Lakhs

Fabrication cost (50% of material cost), Rs = 8.00 Lakhs

**Total estimated cost of the scale down Pokkali paddy harvester, Rs = 24.00 Lakhs**

178

**DESIGN ANALYSIS OF KAU POKKALI PADDY HARVESTER  
TOWARDS THE DEVELOPMENT OF ITS SCALE DOWN PROTOTYPE**

by

**VENKATA REDDY H.K.**

**(2016 - 18 - 010)**

**ABSTRACT OF THE THESIS**

**Submitted in partial fulfilment of the requirement for the degree of**

**MASTER OF TECHNOLOGY**

**IN**

**AGRICULTURAL ENGINEERING**

**(Farm Machinery and Power Engineering)**

**Faculty of Agricultural Engineering and Technology**

**Kerala Agricultural University**



**DEPARTMENT OF FARM MACHINERY AND POWER ENGINEERING**

**KELAPPAJI COLLEGE OF AGRICULTURAL ENGINEERING AND**

**TECHNOLOGY, TAVANUR - 679 573**

**KERALA, INDIA**

**2018**

## ABSTRACT

The term 'Pokkali' used in the common parlance refers to a salt tolerant traditional rice cultivar grown in the coastal saline soils of Kerala, India. The Pokkali field is a unique eco-system prevailing in the coastal tract of Kerala with rich bio diversity and amazing capacity to produce organic rice and shrimp alternatively. Rice is grown during non-saline period and the farmers carry out shrimp culture during the saline phase with both having unique symbiotic benefits. Pokkali areas lie in Trissur, Ernakulum and Alappuzha districts covering a total area of 8500 ha. It spreads over 34 Krishibhavans of these three districts. In the saline, water-logged Pokkali farm lands, rice and shrimps are farmed alternatively. The conventional method of harvesting of Pokkali paddy crop by using sickles. The various farming operations in Pokkali paddy cultivation, the harvesting is done by women labourers by walking on the swampy and marshy inundated paddy fields at waist-deep water, which is laborious, tedious and cumbersome.

Though a number of paddy combine harvesters are commercially available, none cannot be used in such marshy water logged areas for harvesting paddy. Hence, a power operated floating harvester with provisions for harvesting and conveying the ear heads (panicles) of submerged paddy was developed at KCAET, Tavanur. The overall size of the harvester is 9.6 x 2.2x 2.2 m with a total weight of about 3 tonnes. Due to the over size and weight, the manoeuvrability become a great problem for transportation and operation in small paddy lands. It necessitated designing a scale down proto type of the harvester to operate in all Pokkali areas for easy transportation and good manoeuvrability.

The major functions of a Pokkali paddy harvester are floating in water/moving in puddled soil, cutting and conveying of the panicles. The design analysis of the harvester is sequentially carried out for the floating barge, harvesting unit and hydraulic system. Hydraulic drive system consisted of a hydraulic pump, pressure gauge, valves, filters, etc. to guide and control the system. The capacity of the hydraulic tank was 150 litres and double acting hydraulic pump has  $61.0 \text{ l min}^{-1}$ . Harvesting unit of the Pokkali paddy harvester consists of a reel, cutter bar and conveyor. Reel delivers the stalks to the cutting

mechanism, the cutter bar cuts crop and conveys through front conveyor and transferred to in the central conveyor. Width of the cutter bar was 2.1 m with serrated blade to avoid spilling of the stalks. The vertical centre of gravity of the harvester was designed as 0.854m and longitudinal centre of gravity as 4.58 m. It was found out that the design of the existing KAU Pokkali paddy harvester was perfect considering the buoyancy and stability aspects.

The overall size of the newly designed scale down prototype is 6.2 x 1.7 x 1.7 m with a total weight of about 1700 kg. A scale down prototype of the harvester is designed in such a way that to suit for fragmented Pokkali areas. The vertical centre of gravity of the scale down prototype is 0.58 m, longitudinal centre of gravity is 2.67 m and transverse centre of gravity is zero. As the transverse centre of gravity is zero, scale down Pokkali paddy harvester is stable to float and longitudinal centre of gravity lies near to the centre and adjacent to the front and rear side of the harvester, it become a well-balanced machine.

174473

