

173872

1

# **ERGONOMIC INVESTIGATIONS ON HAND ARM VIBRATION OF BRUSH CUTTER FOR THE DEVELOPMENT OF A VIBRATION REDUCING AID**

**By**  
**ASWATHI K.**  
**(2014-18-112)**



**Thesis**

Submitted in partial fulfilment

Of the requirement for the award of degree of

## **MASTER OF TECHNOLOGY IN AGRICULTURAL ENGINEERING (Farm Power and Machinery)**

**Faculty of Agricultural Engineering and Technology**

**Kerala Agricultural University**



*Department of Farm Power, Machinery and Energy*

**KELAPPAJI COLLEGE OF AGRICULTURAL ENGINEERING AND TECHNOLOGY**

**TAVANUR - 679 573, MALAPPURAM**

**KERALA, INDIA**

**2016**

## DECLARATION

I, hereby declare that this project report entitled “**ERGONOMIC INVESTIGATIONS ON HAND ARM VIBRATIONS OF BRUSH CUTTER FOR THE DEVELOPMENT OF A VIBRATION REDUCING AID**” is a bonafide record of research work done by me during the course of research and the thesis has not previously formed the basis for the award to me of any degree, diploma, associateship, fellowship or other similar title, of any other University or Society.

Place: Tavanur

Date: 21.11.2016



**Aswathi K.**

(2014-14-112)

CERTIFICATE

Certified that this thesis entitled “**ERGONOMIC INVESTIGATIONS ON HAND ARM VIBRATION OF BRUSH CUTTER FOR THE DEVELOPMENT OF A VIBRATION REDUCING AID**” is a record of research work independently done by Ms. Aswathi K. (2014-18-112) under my guidance and supervision and that it has not previously formed the basis for the award of any degree, diploma, fellowship, associateship to her.



**Dr. Sureshkumar P. K.**

(Major advisor, Advisory Committee)

Associate Professor,

Dept. of Agri. Engg.

CoH, Vellanikkara.

Place: Tavanur,

Date: 21.11.2016



## CERTIFICATE

We, the undersigned members of the advisory committee of Ms. Aswathi K. (2014-18-112), a candidate for the degree of **Master of Technology in Agricultural Engineering** with major in Farm Power and Machinery, agree that the thesis entitled **“ERGONOMIC INVESTIGATIONS ON HAND ARM VIBRATION OF BRUSH CUTTER FOR THE DEVELOPMENT OF A VIBRATION REDUCING AID”** may be submitted by Ms. Aswathi K.(2014-18-112), in partial fulfilment of the requirement for the degree.



**Dr. Sureshkumar P. K.**  
(Chairman, Advisory Committee)  
Associate Professor,  
Dept. of Agri. Engg.  
CoH, Vellanikkara.



**Dr. Jayan P. R.**  
(Member, Advisory committee)  
Professor and Head  
Dept. of FPME  
KCAET, Tavanur.



**Dr. Bini Sam**  
(Member, Advisory committee)  
Professor  
Dept. of FPME  
KCAET, Tavanur.



**Dr. Sudheer K. P.**  
(Member, Advisory committee)  
Professor  
Dept. of APFE  
KCAET, Tavanur.



  
21/11/16  
**EXTERNAL EXAMINER**

## ACKNOWLEDGEMENT

*I think, it is a matter of pleasure to glance back and recall the path of traverse during the days of hard work and perseverance. It is still great at this juncture to recall all the faces and spirits in the form of teachers, friends, near and dear ones. I would consider this work nothing more than incomplete without attending to the task of acknowledging the overwhelming help I received during this endeavor.*

*I express my deep and sincere regards, profound sense of gratitude and indebtedness to my Guide as well as Chairman of the Advisory Committee, **Dr. Sureshkumar P. K.**, Associate Professor and Major advisor, Department of Agricultural Engineering, CoH, Vellanikkara for untiring supervision, meticulous guidance and benevolent criticisms during the entire course of this investigation. It is my proud privilege to express my heartfelt indebtedness and deepest sense of gratitude for laying out the guidelines of research work. I have real admiration and regards for his full hearted support and untiring help.*

*This would be the right moment to thank **Dr. Hajilal M. S.**, Dean (Ag. Engg.), K.C.A.E.T, Tavanur for his support during the course of the project work.*

*It is my pleasure to pay tribute to **Dr. M. Sivaswami**, Former Dean, K.C.A.E.T, Tavanur for his advice and guidance rendered during this study.*

*My sincere thanks goes to **Dr. Jayan P. R.**, Professor & Head, Department of Farm Power Machinery and Energy, K.C.A.E.T, Tavanur and member of advisory committee for his sustained guidance, constant encouragement, untiring help and insightful consults throughout the period of the study.*

*I express my deep gratitude to **Dr. Bini Sam**, Professor, Department of Farm Power Machinery and Energy, K.C.A.E.T, Tavanur and **Dr. Sudheer K. P.**, Professor, Department of Food and Agriculture Process Engineering, K.C.A.E. T, Tavanur as a members of advisory committee. I am indebted to them for their encouragement and support in my research. Learning from them was always*

*interesting and enjoyable.*

*I take this opportunity to express my sincere gratitude and heartfelt thanks to **Dr. Visalakshi K. P.**, Professor & Head, Dept. of Agrl. Engg, CoH, Vellanikkara for her sustained interest, advices and moral support extended to me to complete this research work.*

*I place my special thanks to **Er. Shivaji K.P.**, Assistant Professor, Department of Farm Power Machinery and Energy, K.C.A.E.T, Tavanur. **Er. Suma Nair**, Assistant Professor, Department of Farm Power Machinery and Energy, K.C.A.E.T, Tavanur, for their deemed support, idea and efficacious advice throughout my project work.*

*It is my pleasure to offer whole hearted thanks to **Dr. S. Krishnan.**, Professor & Head, Department of Agricultural Statistics, CoH, Vellanikkara, for explaining me the statistical techniques required for the study.*

*I would also like to thank all my friends, juniors and seniors who have helped me in one way or the other for the completion of my research work. Especially to **Mr. Amalkumar V.P.**, **Mr. Ignitious**, **Er. Anjana K**, **Er. Ansi K. A**, **Mrs. Sarmila**, **Er. Nimmi Kuruppath**, **Mr. Sreekesh**, **Mr. Bijoy**, **Mr. Sarath**, for their wonderful help and encouragement during the entire project work period.*

*My completion of this project could not have been accomplished without the support of my classmates especially, **Er. Arjun Prakash**, **Er. Neetha shaju**, **Er. Saranya S.**, **Er. Ayisha Mangat**, **Er. Dayand Kumbar**, **Er. Madhu Kumara D.M.**, **Er. Dipak S. Khatawakar**, **Er. Salsan K.** **Er. Jomol T. Joseph**, and **Er. Vimitha T.** for their constant and invaluable support rendered during the conduct of project work.*

*My heartfelt thanks to **Kerala Agricultural University** for providing me the KAU merit scholarship and for having proffered me a chance to study in this institution.*

*I am in dearth of words to express my unboundful gratitude and love to*

*the living gods, my parents Smt. **Lakshmi Krishnan** and Sri. **V. Krishnan** for their unbounding love and dedicated efforts to educate me to this level without whose encouragement brings out the best in every one of my endeavours.*

*Above all, I humbly acknowledge the grace and blessings of the supreme power for enlighten my life and fulfilling this well nurtured dream.*

***Aswathi K.***

*Dedicated to*  
*My*  
*Family*



## CONTENTS

Chapter No.	Title	Page No.
	LIST OF TABLES	ix
	LIST OF FIGURES	xi
	LIST OF PLATES	xii
	SYMBOLS AND ABBREVIATIONS	xiii
1	INTRODUCTION	1
2	REVIEW OF LITERATURE	4
3	MATERIALS AND METHODS	26
4	RESULTS AND DISCUSSION	56
5	SUMMARY AND CONCLUSION	80
	REFERENCES	84
	APPENDICES	91
	ABSTRACT	

### LIST OF TABLES

Table No.	Title	Page No.
3.1	Age and experience of selected subjects	27
3.2	Anthropometric dimensions selected for the study	28
3.3	Anthropometric instruments used for the study	28
3.4	Specifications of VIVA FITNESS T1029 computerised treadmill	35
3.5	Specifications of brush cutters	39
3.6	Specifications of cutter heads	40
3.7	Specifications of VB-8201HA Vibration meter	43
3.8	Experimental design	50
3.9	Overall discomfort rating (ODR)	52
3.10	Overall safety rating (OSR)	53
3.11	Overall ease of operation rating	53
4.1	Anthropometric dimensions of subjects	57
4.2	Anthropometric strength measurements of subjects	58
4.3	Heart rate and oxygen consumption of subjects during calibration	58
4.4	Measured BMR of six subjects	59
4.5	Linear equation showing relationship between the heart rate(X) and oxygen consumption(Y) of subjects	61
4.6	VO <sub>2</sub> max for selected subjects	62
4.7	Heart rate, O <sub>2</sub> consumption and energy expenditure for 2 stroke brush cutter using different cutter heads	65
4.8	Heart rate, O <sub>2</sub> consumption and energy expenditure for 4 stroke brush cutter using different cutter heads	65
4.9	Peak maximum values of HAV at right handles of brush cutter for male subjects	67
4.10	Peak minimum values of HAV at right handles of brush cutter for male subjects	67
4.11	RMS maximum values of HAV at right handles of brush cutter for male subjects	68
4.12	RMS minimum values of HAV at right handles of brush cutter for male subjects	68
4.13	Peak maximum values of HAV at right handles of brush cutter for female subjects	69

4.14	Peak minimum values of HAV at right handles of brush cutter for female subjects	69
4.15	RMS maximum values of HAV at right handles of brush cutter for female subjects	69
4.16	RMS minimum values of HAV at right handles of brush cutter for female subjects	70
4.17	Peak maximum values of HAV at left handles of brush cutter for male subjects	70
4.18	Peak minimum values of HAV at left handles of brush cutter for male subjects	71
4.19	RMS maximum values of HAV at left handles of brush cutter for male subjects	71
4.20	RMS minimum values of HAV at left handles of brush cutter for male subjects	71
4.21	Peak maximum values of HAV at left handles of brush cutter for female subjects	72
4.22	Peak minimum values of HAV at left handles of brush cutter for female subjects	72
4.23	RMS maximum values of HAV at left handles of brush cutter for female subjects	72
4.24	RMS minimum values of HAV at left handles of brush cutter for female subjects	73
4.25	BPDS of male subjects for different brush cutter operation	78
4.26	BPDS of female subjects for different brush cutter operation	78
4.27	BPDS of male subjects for operating brush cutter with attachment	79
4.28	BPDS of female subjects for operating brush cutter with attachment	79

LIST OF FIGURES

Figure No.	Title	Page No.
2.1	Representation of RMS value and the peak value of acceleration	14
2.2	Coordinate systems for hand	16
2.3	Frequency-weighting curve $W_h$ for hand transmitted vibration	18
3.1	Plan of the selected brush cutter with dimensions	39
3.2	Operating position of brush cutter	41
3.3	Measurement direction and position of fastening of accelerometers on machines with right and left handle	42
3.4	Side view of vibration reducing aid	46
3.5	Plan of vibration reducing aid	46
3.6	Plan of developed vibration reducing aid attached to the brush cutter shaft	48
3.7	Side view of developed vibration reducing aid attached to brush cutter shaft	49
3.8	Regions for evaluating BPDS	54
4.1	Calibration chart for oxygen consumption of male subjects	60
4.2	Calibration chart for oxygen consumption of female subjects	61
4.3	Energy expenditure of male subjects for 2 stroke and 4 stroke brush cutter operation	63
4.4	Energy expenditure of female subjects for 2 stroke and 4 stroke brush cutter operation	64
4.5	ODR of male and female subjects while operating brush cutters	74
4.6	ODR of male and female subjects while operating brush cutter with attachment	74
4.7	OSR of male and female subjects while operating brush cutter	75
4.8	OSR of male and female subjects while operating brush cutter with attachment	76
4.9	OER of male and female subjects while operating in brush cutters	77
4.10	OER of male and female subjects while operating brush cutter with attachment	77

## LIST OF PLATES

Plate No.	Title	Page No.
2.1	Defining of orthogonal directions on the tractor and the operator for measurement	8
2.2	Brush cutter position on human body	9
2.3	GA2001 HARM Vibration meter	14
3.1	Integrated Composite Anthropometer	30
3.2	Weighing balance	30
3.3	Conical device for measuring internal grip diameter	30
3.4	Skin fold diameter measuring device	30
3.5	Vernier calliper	30
3.6	Measuring tape	30
3.7	Baseline 300 pound Digital hand dynamometer	31
3.8	Mechanical Pinch Gauge	31
3.9	Baseline Lift dynamometer	31
3.10	Polar RS300X Heart rate meter	33
3.11	Benedict-Roth Recording Spirometer	33
3.12	VIVA FITNESS T1029 computerised treadmill	35
3.13	Measurement of BMR using Benedict-Roth Recording Spirometer	36
3.14	Calibration Process	37
3.15	Nylon rope cutter head	40
3.16	2-blade type cutter head	40
3.17	3-blade type cutter head	40
3.18	Circular type cutter head	40
3.19	VB-8201HA Vibration meter	43
3.20	Developed vibration reducing aid	47
3.21	Vibration reducing aid attached to brush cutter	51
4.1	Brush cutter with vibration reducing aid	66

## LIST OF SYMBOLS AND ABBREVIATIONS

-	: minus
%	: per cent
&	: and
/	: per
+	: plus
<	: Less than
>	: Greater than
±	: Plus or minus
°	: degree
A(8)	: 8-h energy-equivalent frequency-weighted vibration total value
Agri.	: Agricultural
Beats min <sup>-1</sup>	: Beats per minute
BPDS	: Body part discomfort rating
cm	: Centi meters
CoH	: College of Horticulture
dB	: decibel
Dept.	: Department
D <sub>y</sub>	: group mean of exposure time of hand arm vibration
EAV	: Exposure Action Value
ELV	: Exposure Limit Value
ESA	: Ergonomic and Safety in Agriculture
<i>et al.</i>	: And others
etc.	: Etcetera
F.P.M.E.	: Farm Power Machinery and Energy
g	: Gram
h	: hour
HAV	: Hand Arm Vibration
HAWS	: Hand Arm Vibration Syndrome

HR	: Heart rate
Hz	: Hertz
i.e.,	: That is
ISO	: International Standard Organization
K.C.AE.T.	: Kelappaji College of Agricultural Engineering and Technology
KAU	: Kerala Agricultural University
kg	: Kilogram
l	: litre
$l \text{ min}^{-1}$	: Litre per minute
$m \text{ s}^{-1}$	: Meter per second
$m \text{ s}^{-2}$	: Meter per second squared
min	: minute
$\text{min}^{-1}$	: Per minute
mm	: Milli meter
MSDs	: Musculoskeletal disorders
N	: newton
NIOSH	: National Institute for Occupational Safety and Health
OCR	: Oxygen consumption Rate
ODR	: Overall Discomfort Rating
OER	: Overall Ease of Operation
OSR	: Overall Safety Rating
RMS	: Root-mean-squared
S.D.	: Standard deviation
viz.	: namely
$\text{VO}_2$	: Volume of oxygen consumed
$\text{VO}_2 \text{ max}$	: Maximum aerobic capacity
WBV	: Whole Body Vibration
$W_h$	: frequency weighting

# *Introduction*



## CHAPTER 1

### INTRODUCTION

Mechanical vibration is a common occurrence in everyday life. It can be from many sources such as moving vehicles, vibrating machines, tools and buildings. Severe vibration affects the comfort, efficiency, safety, health and wellbeing of people exposed to it. Since vibration is a common factor at various workplaces, it has been recognized as an occupational health hazard. It should thus be assessed and controlled, as any other hazard, to minimize or eliminate health risks. Agricultural machinery, especially powered tools/equipment, are an important source of vibration. With increasing adoption of agricultural machinery/equipment for agricultural mechanization, it is necessary to adopt ergonomic considerations for a proper design of any agricultural equipment.

The human response to vibration depends on the part of the body which is exposed to vibration. There are two major types of vibrations transmitted to human body *viz.* whole-body vibration (vibration transmitted to the whole body through a supporting surface such as the feet of a standing person or the buttock of a seated person) and segmental vibration (vibration applied to a part of the body). When vibration is applied to the hand, it is termed hand arm vibration (HAV). In recent years, there have been many reports of Hand Arm Vibration Syndrome (HAVS) reported among people who work in agriculture, horticulture and landscape gardening.

The brush cutter is a machine, commonly petrol-operated, and widely used in agriculture, for weeding and clearing lands, trimming grass and cutting brush woods. It is a power tool, worn on shoulder of the operator, and consists of a rotary cutter head at the end of a boom for clearing various kinds of brush woods and grasses. During operation, it is supported / borne by human operator simultaneously on his shoulders and his/her right feet and controlled with the hands. While operating brush cutters, a part of the vibration produced is transmitted to the human body. The equipment is operated in a standing position, with the operator bending slightly forward. Hence, the human spine is exposed to vibrational waves from two

directions: through the shoulders and through the right foot. Besides this, the vibrations created at the engine and the cutter head, are also transmitted to the body through the hands.

Each part of the human body has its own resonance frequency; and therefore, it reacts differently to different frequencies. The extent to which the human body is affected depends on the frequency of the vibration to which it is exposed. Low-frequency body vibrations (<1Hz) can produce a feeling of illness, while body vibrations between 1 and 100 Hz, especially between 4 and 8 Hz, can lead to chest pains, difficulties in breathing, low back pain and impaired vision. The possible consequences of hand–arm vibration frequencies between 8 and 1000 Hz are reduced sensitivity and dexterity of the fingers, vibration ‘white finger’, as well as muscle, joint and bone disorders (IS/ISO 2631-1, 1997).

The workers involved in the operation of these machines are generally contract workers, with little or no awareness about the effect of vibration on their health. These workers are exposed to HAV during work. Many times the acceleration level to which these operators exposed to HAV exceeds the acceptable daily exposure level of  $2.5 \text{ m s}^{-2}$  and the typical daily run time of 4 h. This points to the need of specified action to reduce such risk. The exposure limit value is the level of daily exposure set out for any worker which must not be exceeded and for HAV the daily exposure limit value is  $5 \text{ m s}^{-2}$ . An ergonomic study on these brush cutters will reveal the extent of vibrations transmitted to the operator’s body.

The word ergonomics is derived from the Greek words *ergon* (work) and *nomos* (law). In several countries, the term human factors are also used. Ergonomics (or human factors) is the scientific discipline concerned with understanding of the interactions among humans and other elements of a system; and the profession that applies theory, principles, data and methods to design, in order to optimize human well-being and overall system performance.

Any attempt to reduce vibrations transmitted to the human body from power tools would be beneficial to those who are actually using such tools. Keeping this in view, the present investigation entitled “**Ergonomic investigations on hand arm vibrations of brush cutter for the development of a vibration reducing**

**aid**" has been planned and carried out at KCAET, Tavanur with the following objectives.

1. To study the ergonomic aspects and hand transmitted vibrations of brush cutters.
2. To design and develop suitable vibration reduction aid for brush cutters.
3. To evaluate the brush cutter and vibration reduction aid in field.

*Review of Literature*

## CHAPTER II

20

### REVIEW OF LITERATURE

A comprehensive review of research work carried out in the field of ergonomic analysis of agricultural implements with special reference to hand arm vibration conducted by different researchers are briefly reported in this chapter under the following sub titles.

- 2.1 Vibration
  - 2.1.1 Whole body vibration (WBV)
  - 2.1.2 Hand Arm Vibration (HAV)
  - 2.1.3 Effects of Hand Arm Vibration
- 2.2 Vibration measuring instrument
- 2.3 Assessment of vibration
- 2.4 Selection of subjects
- 2.5 Calibration of subjects
- 2.6 Anthropometric dimensions
- 2.7 Physiological response of subjects
- 2.8 Subject Rating of Perceived Exertion (RPE)
  - 2.8.1 Overall Discomfort Rating (ODR)
  - 2.8.2 Overall Ease of operation rating (OER)
  - 2.8.3 Overall safety Rating
  - 2.8.4 Body Part Discomfort Score (BPDS)

#### 2.1 VIBRATION

Vibration is typically an oscillating motion of a mechanical system or body. The magnitude of vibration can be described by the displacement (mm) of the motion above some reference point or, alternatively by the rate of change of this displacement (*i.e.*, velocity ( $\text{m s}^{-1}$ ) or acceleration ( $\text{m s}^{-2}$ ) with reference to time.

Mehta *et al.* (1997) suggest that there were many factors which influenced human response to vibrations. These factors can be grouped into two categories of variables *viz.* intrinsic variables and extrinsic variables. Intrinsic variables include factors such as population type (age, sex, size, and fitness), behavioural attributes (experience, expectation, arousal, motivation, financial involvement) and body posture activities which are directly linked with the operator. Extrinsic variables include factors such as vibration magnitude, vibration frequency, vibration axis, vibration input position, vibration duration, seating restraints and other environmental influences (noise, heat, acceleration, light) which are not directly linked to the operator.

There are two types of vibration exposure *viz.* segmental vibration and whole body vibration. Segmental vibration exposure refers to exposure that is mainly transmitted to, and concentrated on, a specific part of the body – such as the hand, arm, or leg. Whole body vibration exposure is when vibration is transmitted throughout all or most of the body.

As reported by Griffin (1990), low frequency vibrations (1-20 Hz) usually have effect on the whole body (low back pain, sickness, mobile equilibrium, visual disorders), whereas those of a high frequency (20-1000 Hz), which characterize hand-held power tools, generate cumulative trauma disorders on the hand-arm System.

The vibration exposure of worker can be decreased by proper selection and maintenance of tool. Vibration levels associated with power hand tools depend on tool properties, including size, weight, method of propulsion, handle location, and the tool drive mechanism. The excessive vibration and shocks can be eliminated through better ergonomic tool designs.

### **2.1.1 Whole body vibration**

Whole body vibration occurs when a person stands or sits on a vibrating vehicle, machine or surface. The vibration is transmitted through supporting surfaces such as the standing person's feet, the buttocks of a seated person, and the supporting areas of a reclining person.

Whole body vibration exposure often comes from a variety of different vibration sources from one or more components of a machine, vehicle or surface.

In tractors, vibrations generated at the engine are transmitted to the driver's body through the seat, the frame and the controls. Exposure to these vibrations over a longer period can lead to serious health issues. Vibration exposure measurement data indicates that the vehicles drivers are exposed to vibration levels in excess of ISO standards, and that common control measures such as seat suspension are often ineffective. Due to this numerous back disorders, including lumbago, sciatica, generalized back pain, and intervertebral disc herniation and degeneration are found. Elevated risks are consistently observed after five years of exposure.

The purpose of the whole-body vibration risk assessment is to enable operator/workers to make a valid decision about the measures necessary to prevent or adequately control the exposure of workers to whole-body vibration.

Cvetanovic and Zlatkovic (2013) suggested that during short-term work (about 1 hour), acceleration and daily exposure A(8) values in tractors with lower power (IMT 533) were almost negligible and harmless. In tractors with higher power (IMT 560), these values were significantly higher than daily exposure action value (EAV), but still lower than exposure limit value (ELV), which indicated moderate risk. In case of IMT 558, for two-hour work, the values of daily exposure A(8) were  $1.93 \text{ m s}^{-2}$  which was significantly higher above ELV and it indicated unacceptable risk.

Scarlett *et al.* (2007) reported that Tractor WBV emission levels were dependent upon the nature of field operation performed, and independent of vehicle suspension system capability (due to the dominance of horizontal vibration). This trend was reversed during on-road transport. Nine per cent of tractor field operations approached or exceeded the PA(V)D Exposure Limit Value (ELV) during 8 h operation, but it is increased to 27 per cent during longer working days. Around 95 per cent of 'on-farm' vehicles exceeded the EAV during an 8-h day. They suggested that 'on-farm' WBV data collection is required to enable creation of WBV emission database for agricultural tractor operations, to enable estimation of WBV exposure by employers.

A study was conducted by Okunribido *et al.* (2007) to investigate worker exposure to posture demands, manual materials handling and whole body vibration as risks for low back pain. Vibration measurements were obtained at the seat and according to the recommendations of ISO 2631 (1997). The results showed that taking regular breaks from sitting during driving and fitting buses with remotely operated retracting assess ramps and lift platforms and use of buses with manual transmissions rather automatic transmissions are strategies that can help in reduction of low back pain.

Petrovic *et al.* (2005) while evaluating of the whole body vibration levels found that multiplied vibration levels that occur in a complex system such as tractor are transmitted to the operator through the seat, controls and the steering wheel, and through floor of the cab and foot controls.

It is impossible to make direct measurement of the force that generates vibrations. Thus measuring of the system response to the force-vibrations is carried out during analysis. The orthogonal directions on the tractor and the operator for measurement is presented in Plate 2.1.

Although well-known world manufacturers are dedicated for reducing vibrations, most of the world's tractors are twenty and more years old and do not meet basic ergonomic requirements.

Thus it is important to measure vibration levels constantly, evaluate them and determine the risk for driver's safety. Depending on the risk, organizational and technical measures for vibration reduction should be taken. This is true for all types of equipment that produce vibrations.

Research has been carried out by Marul and Karabulut (2012) for decreasing vibration effect on driving seat of tractors in land conditions by introducing cushions made of different materials. In vibration isolation, ordering has been achieved as wool, cotton and sponge and without a cushion, respectively. Wool cushion has the best isolation.



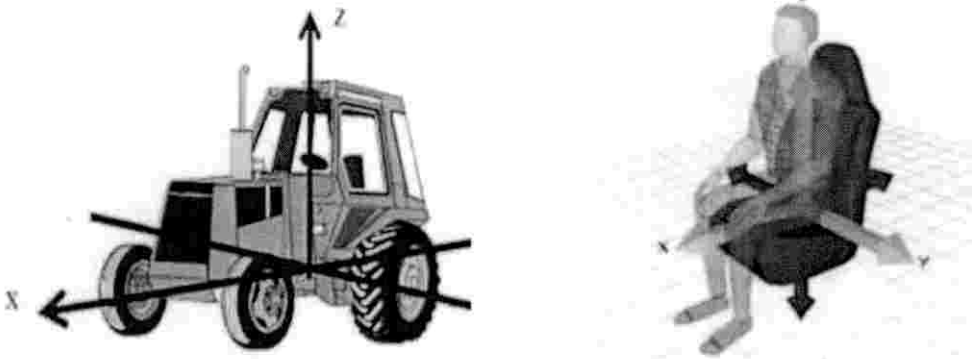

**Plate 2.1 Defining of orthogonal directions on the tractor and the operator for vibration measurement**

(Source: Petrovic *et al.*, 2005)

### 2.1.2 Hand Arm Vibration (HAV)

Every day agro-forestry workers are exposed to health and safety risks, due to work environment and the machineries they use. Some of these risks, vibrations for example, are usually under estimated by workers as well, because vibrations do not represent an immediate risk for the health. The vibrations can cause some professional diseases whose symptoms can appear after many years too. This is not a good reason to ignore the problem; in fact the consequences of a long exposure time can be very serious.

Monarca *et al.* (2008) have done the assessment of the risk for the hand-arm system at which operators were exposed during the utilization of portable equipment, which was largely used in agricultural sector. Six models of shoulder portable blowers, four brush-cutters, one chain saw and one hedge cutter have been analyzed. The procedure has been carried out following ISO standards. It was possible to establish the maximum exposure times for every instrument in accordance with the European Directive 2002/44/CE of 25 June 2002. The study has shown low ( $A(8) < 2,5 \text{ m s}^{-2}$ ), intermediate ( $2,5 \text{ m s}^{-2} < A(8) < 5,0 \text{ m s}^{-2}$ ) and high ( $A(8) > 5,0 \text{ m s}^{-2}$ ) risk situations for the hand-arm system exposure.

Brush cutter is a power tool worn on a shoulder harness consisting of a rotary head with a small circular saw at the end of a shaft, for clearing various kinds of brush woods (Anon1, 2015).



**Plate 2.2 Brush cutter position on human body**

(Source: Truta *et al.*, 2013)

Truta *et al.* (2013) conducted studies on the contact points with the excitation forces in brush cutters and found that three of them were on the right of the tool and two of them on the left shoulder and right shoulder that sustain the brush cutter's harness. The details of excitation forces are given Plate 2.2. In given Plate 2.2, 1 represents the contact between left hand and left handle 3 represents the contact between right hand and right handle. There was a strong contact between the tool and right feet in point 2. Points 3 and 4 are the areas where the body sustains the harness and shoulders girdle.

Hand-arm vibration syndrome is disorder resulting from prolonged exposure to vibration, specifically to the hands and forearms while using vibrating tools. Symptoms include numbness, tingling, and loss of nerve sensitivity. (Anon2, 2016).

Many studies indicated that extended exposure to mechanical vibrations can induce degeneration of the vascular and sensio-neural systems in the hand called hand-arm vibration syndrome (HAVS). Vibration injuries are divided into three subgroups, *i.e.*, Neurological disorder, vascular disorder and Muscle skeletal disorder. These damages can occur alone or in combination.

According to ISO 5349-1(2001), the following factors the effects of human exposure to hand-transmitted vibration in working conditions:

- Frequency spectrum of vibration
- Magnitude of vibration
- Duration of exposure per working days and
- Cumulative exposure to date

The duration of vibration exposure was expressed in daily exposure duration. Daily exposure duration is the total time for which the hand is exposed to vibration during a working day. The vibration exposure time may be shorter than the time for which the person is working with the power tools or workplaces and it is denoted as  $A(8)$ .

Azmir *et al.*(2014) conducted hand arm vibration characteristics in brush cutter and found that daily exposure value vary from 2.7 to 29.1  $m\ s^{-2}$  with a mean value of 8.81 and S.D 5.02  $m\ s^{-2}$  for right hand. The left hand it varied from 2.1 to 20.7  $m\ s^{-2}$  with a mean value of 6.13 and S.D 3.01  $m\ s^{-2}$ . The maximum vibration magnitude on the left hand was in 'Y' direction of machine *i.e.*, 26.4  $m\ s^{-2}$ .

Truta *et al.* (2013) conducted an experiment to evaluate the influence of brush cutter's vibration on human body. The experiment was carried out with an accelerometer which was attached on the right and left hands. Its contact with the body was created between a special supports, right on the skin. An elastic band kept the accelerometer and its support in unmovable position and vibration measurements were taken. For the left wrist the highest value was much smaller than that of the right hand.

A big difference between the left and right hand values were observed at different moments of measurements.

Reddy *et al.* (2010) modified the brush cutter machine and analyzed exposure of vibration levels in the revised brush cutter. Hand positions were defined with respect to the position of left hand on handle. In first position (P1), left hand holds handle at the extreme end, while in second (P2) and third (P3) positions, left hand was at a distance  $1/4^{\text{th}}$  and  $1/5^{\text{th}}$  of the total length from extreme end respectively. Right hand was always at the right end of handle. In the study, only largest single axis component were noted down. Magnitudes of velocity, which were significant than accelerations along Y-axis, were noted down as output parameters in various hand positions (P1, P2 and P3) on handle. P2 was advisable for minimum hand vibrations. Optimum values of operating parameters for minimum hand vibrations in all positions were: nylon thread length, 20 cm, and engine speed, 3300 rpm.

Laszlo (2010) in his study significant differences were measured in weighted acceleration of the brush cutter, especially in the x and z directions for the front handle and all directions for the rear handle. In this study the holding positions were the following: the cutting head was parallel to the ground, the cutting head was tilted by  $45^\circ$  to the left and tilted by  $45^\circ$  to the right (*i.e.*, simulating grass trimming at a hill side). Tilting the brush cutter to the left increased the vibration exposure, but tilting to right almost doubled the exposure. The greatest difference in vibration exposure of the normal and tilted position to the right was  $2.527 \text{ m s}^{-2}$  at the rear handle during cutting. These results suggest that the change in engine position could increase the risk of unbalance and as a result, the vibration exposure.

Mallick (2008) conducted a study to optimize handle design parameters. The three parameters selected for this study were length (30, 40 and 50cm), material of the cap of handle (wood, aluminium and nylon) and angles of the handle ( $0^\circ$ ,  $45^\circ$  and  $90^\circ$ ). The new handle design resulted in 18% lower HAV. The levels of factors that produce lowest HAV are length of the handle at 30 cm, angle of the handle at  $90^\circ$ , material of the cap of the handle at nylon.

### 2.1.3 Effects of hand transmitted vibration

According to IS/ISO 5349-1(2001) guidelines equation (2.1) was used to estimate minimum exposure duration at which 10% of hand held grass cutter workers are exposed to a risk of vibration induce white finger.

$$D_y = 3.18(A(8))^{-1.06} \quad \dots 2.1$$

Where; A (8) is the daily vibration exposure ( $m s^{-2}$ )

$D_y$  is the group mean of exposure time of hand arm vibration (year).

Daily vibration exposure values were also calculated with the mean total exposure duration in years which may be expected to produce episodes of fingers blanching for each types of machine for an experiment.

Azmir *et al.* (2014) conducted a study to evaluate hand arm vibration characteristics of five different hand held grass cutter machines. The vibration value that were measured in this study show that worker's hands will be predicted to induce fingers blanching in 10 per cent of the exposed person after less than 3.7 years. They also suggested that the operating time should not exceed maximum 2 hours per daily to protect them from HAVS diseases.

Uemura *et al.* (2014) conducted subjective test on handle vibration feeling on brush cutter. Quantification of vibration feeling was done. Frequency characteristics of vibration feeling were clarified. Handle vibration from 100 Hz to 200 Hz was found to be large and handle pipe structure had high influence on large vibration. The handle vibration and vibration feeling were reduced very much for modified machine considering total weight of the machine.

Yoshida *et al.* (2013) reported that the vibration reduction should not increase total weight because the light weight is one of important appeal points of the balancing trimmer. They also found that the vibration at the frequency band from 100 to 250 Hz was very high and the frequency was to be reduced to improve it. To reduce vibration response of the body of balancing trimmer at the high frequency without additional total weight, they tried to resonance frequency down by low stiffness of a part. Decreasing the thickness of handle pipe, attachment of concentrated mass, and

modification of rubber bush were tried in the experiment. The vibration response of handle at the high frequency was reduced 20 dB at maximum. In the operational condition (engine running condition), the vibration at the high frequency band was found to be reduced much by the countermeasures.

According to Laszlo (2010) the dominant frequency range (125 Hz-160 Hz) did not changed, but measured vibration magnitude was found to be increased by 14.3-29.8 per cent within increasing operating time in a study with brush cutter.

## 2.2 VIBRATION MEASURING INSTRUMENT

Sam *et al.* (2007) used ENDEVCO Istron model 750-10 accelerometer of B & K instrument for measuring vibration at different components of the walking and riding type power tiller. The measurements were taken in untilled and tilled field using rotovator. The accelerometer was mounted on the engine top, chassis, transmission gear box, root of handle bar, handle and seat of power tiller.

According to Mac Millan (2007), the magnitude of vibration is usually indicated by the acceleration 'a', measured in  $m\ s^{-2}$ . Because the magnitude of the acceleration is continually changing, a single overall value was introduced. In most cases, when vibration does not contain shocks, the acceleration magnitude is expressed by the root-mean-square (RMS) value given in equation 2.2. (Figure 2.1)

$$a_{rms} = \sqrt{\frac{1}{T} \int_0^T a^2(t) dt} \quad \dots 2.2$$

Fereydooni *et al.* (2012) conducted an investigation to measure and analyze transmitted vibration on different parts of human body and to compare effect of change engine rotation and ground type on operator of tractors and implements. Universal tractor and Ferguson 285 and 299 model tractors with mould board plough and disk plough were used. Hand arm vibration of operator in 1300, 1500 and 1700 rpm in ploughed field and unploughed field was measured using GA2001 HARM Vibration

meter (Plate 2.3). Main parameters of vibration such as acceleration, velocity and displacement for different vibration levels and in three directions were measured.

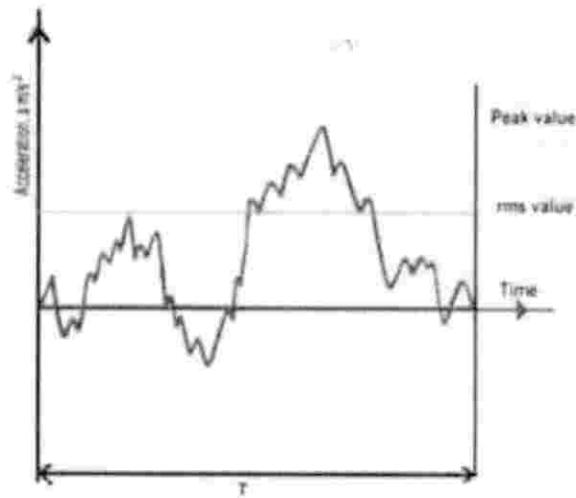

**Figure 2.1 Representation of RMS value and the peak value of acceleration**

(Source: MacMillan, 2007)

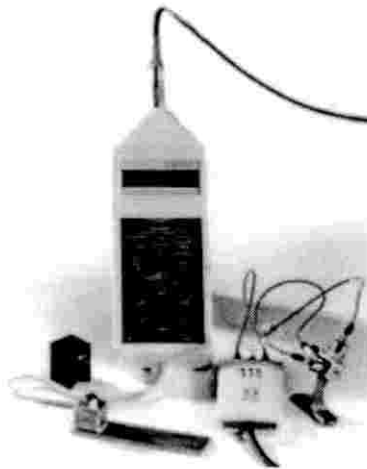

**Plate 2.3.GA2001 HARM Vibration meter**

Solecki (2012) conducted studies to recognize and evaluate the annual exposure of farmers to whole body mechanical vibration on selected family farms of mixed production profile (plant-animal). Both time-schedule and vibration measurements

were carried out while performing basic field and transport activities by farmers during a calendar year. The scientific instrument SVANTEK was used, which satisfied the research requirements, including: SVAN 912 AE portable sound and vibration analyzer, SV 06A four-channel module, and Emsonmat PD 3s triaxial seat sensor. The devices were equipped with correction filters, referring to the three spatial vibration directions, and marked by the symbols:  $W_k$  (whole body vibration, vertical, 'Z' axis) and  $W_d$  (whole body vibration, horizontal 'X' or 'Y axes), which allowed in obtaining of frequency corrected vibration acceleration.

Tint *et al.* (2010) conducted studies with objective of measuring the noise and vibration levels from the lawn-maintenance machines and assess the health risk associated with them. Vibration was determined with 3 physical characteristics *viz.* vibration acceleration, velocity and amplitude and was measured using a hand-held Vibration Dosimeter and Analyser (SV 100).

### 2.3 ASSESSMENT OF VIBRATION

The measurement and risk assessment of hand-transmitted vibration was mostly based on the guidelines and dose-response relationship provided in ISO-5349 standard.

According to ISO-5349 standard, vibration entering the hand contains contributions from all three measurement directions. It was assumed that vibration in each of the three directions was equally detrimental. Measurements should therefore made for all three directions as shown in Figure 2.2.

The evaluation of vibration exposure is based on a quantity that combines all three axes. This is the vibration total value,  $a_{hv}$ , and is defined as the root-sum-of-squares of the three component values:

$$a_{hv} = (a_{hw_x}^2 + a_{hw_y}^2 + a_{hw_z}^2)^{1/2} \quad \dots (2.3)$$

Where,  $a_{hv}$  is vibration total value;

$a_{hw_x}$ ,  $a_{hw_y}$  and  $a_{hw_z}$  for values of  $a_{hw}$ , in  $m\ s^{-2}$  for axes denoted x, y, and z respectively



$a_{hw}$  is root-mean-square(r.m.s) single axis acceleration value of the frequency-weighted hand transmitted vibration in  $m\ s^{-2}$

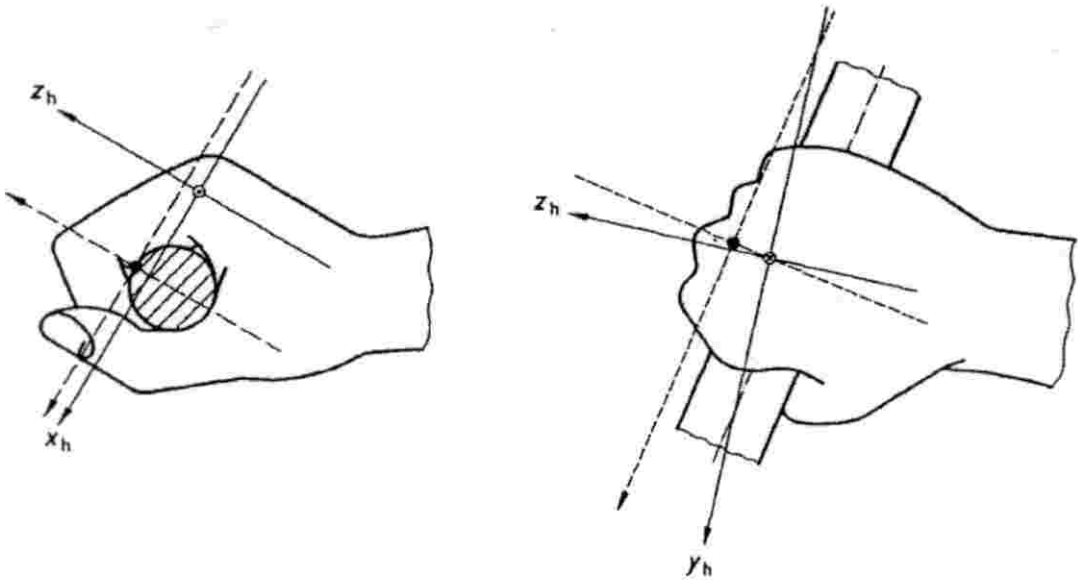

**Figure 2.2 Coordinate systems for hand**

(Source: ISO-5349-1, 2001)

In order to facilitate comparisons between daily exposures of different durations, the daily vibration exposure shall be expressed in terms of the 8-h energy-equivalent frequency-weighted vibration total value  $a_{(eq,hv)}$ , and it is denoted  $A(8)$ .

$$A(8) = \sqrt{\frac{1}{T_0} \sum_{i=1}^n a_{hvi}^2 T_i} \quad \dots (2.4)$$

Where,  $T$  is the total daily duration of exposure to the vibration  $a_{hv}$ ;

$T_0$  is the reference duration of 8 h (28800 s).

Directive 2002/44/EC gave exposure limit values and exposure action values of vibration. It also specified employer's obligations with regard to selecting and assessing risks, sets out the measures to be taken to reduce or avoid exposure and details to provide information and training for workers. Any operator who intends to hold out

work involving risks coming up from exposure to vibration must put into effect a sequence of protection measures before and throughout the work.

Solecki (2012) explained a variety of approaches by carrying out time schedules of agricultural activities, and measurements of frequency weighted vibration acceleration ( $\text{m s}^{-2}$ ), expressed as effective values (RMS) for each of three spatial directions on the seat surface within the period of a whole year. The basic vibration parameter was vibration dose (d) and the values of total monthly vibration dose, mean equivalent daily vibration dose, and mean equivalent daily vibration acceleration were determined. In order to evaluate the level of farmer's exposure to whole body mechanical vibration, a vibration parameter was used called a vibration dose (d), calculated by the formula:

$$d = \sum_{i=1}^n a_{w,i}^2 \cdot t_i \quad \dots 2.5$$

Where, d -vibration dose in  $\text{m}^2\text{s}^{-4}\cdot\text{h}$

$a_{w,i}^2$  -vibration intensity in frequency weighted acceleration value

$t_i$  -vibration duration within the specified time intervals i

According to ISO 5349-1(2001) the frequency weighting  $W_h$  reflects the assumed importance of different frequencies in causing injury to the hand. The range of application of the measured values to the prediction of vibration injury is restricted to the working frequency range covered by the octave bands from 8 Hz to 1000 Hz shown in Figure 2.3. Band limiting high pass and low pass filters restrict the effect on the measured value of vibration frequencies outside this range where the frequency dependence is not yet agreed.

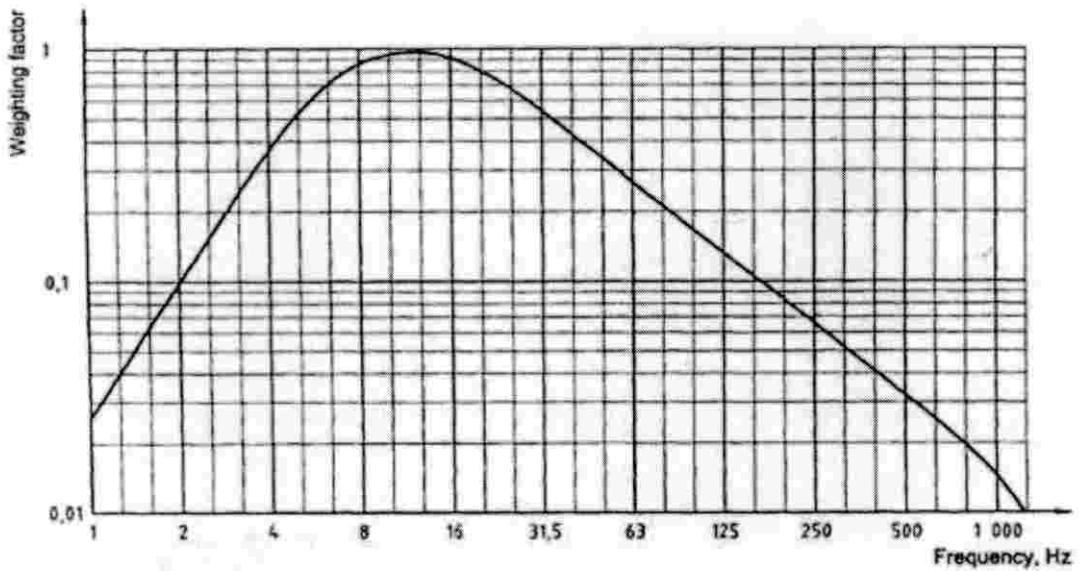

**Figure 2.3 Frequency-weighting curve  $W_h$  for hand transmitted vibration**

(Source:ISO 5349-1, 2001)

The measurement of  $a_{hw}$  requires the application of frequency weighting and band limiting filters.

$$a_{hw} = \sqrt{\sum_i (W_{hi} a_{hi})^2} \quad \dots (2.6)$$

where,  $W_{hi}$  -weighting factor for the  $i$  th one-third-octave band

$a_{hi}$  – root mean squared acceleration measured in the  $i$  th one-third-octave band, in  $m\ s^{-2}$

## 2.4 SELECTION OF SUBJECTS

The selection of subjects plays an important role in conducting the ergonomic investigations. The subjects should be medically and physically fit to undergo trials.

Yadav *et al.* (2010) suggests that all the subjects should be free from physical abnormalities and muscular-skeletal problems. Previous studies indicate that for the design purposes either one of boundary values (5<sup>th</sup> or 95<sup>th</sup> percentiles) or mean value was used depending upon dimensional element. If the equipment is to be operated by

women, the strength data of the female must be considered in the design along with male strength data.

The technological development and transfer programmes are generally carried out on the assumption that the technologies are either gender neutral or that the men are the main users and decision makers.

Joshi and Veerkumar (2013) claimed assuming gender neutral is often incorrect because women have quite different technological needs than men due to their different ergonomical characteristics, level of education, experiences, skills and gender related factors. Due to this many programmes have been proved to be ineffective as the technologies developed are not relevant to the needs of women as the users.

Singh *et al.* (2010) pointed out that if eight hours of work is considered as one man day, the Indian rural women work more than two man day's everyday both in home and farm together. During the activities they adapt unnatural body posture due to which their physiological workload increases and also they faces many types of musculo-skeletal problems as a result the efficiency of women to work decreases to a greater extent.

## 2.5 CALIBRATION OF SUBJECTS

To evaluate the physiological workload using heart rate, the relationship between heart rate (HR) and oxygen consumption rate (OCR) must be determined for each subject.

Sam *et al.* (2007) studied ergonomic aspects of power tiller and showed that both HR and OCR have to be measured in the laboratory at a number of sub maximal loads. The process was named as calibration of subjects. With linear relationship of the HR and OCR, the HR during the field trials were predicted from the calibration charts. Since it is difficult to measure the oxygen consumed by the subjects while performing various types of tasks, the subjects were calibrated in the laboratory.

The oxygen uptake in terms of  $VO_2$  max was compared with acceptable workload and work pulse was compared with the limit of continuous performance.

## 2.6 ANTHROPOMETRIC DIMENSIONS

The body dimensions vary with age, sex, and ethnic groups. There is considerable difference between the anthropometric data of Indian and Western population emphasizing the need of generating anthropometric database for agricultural workers (Gite and Singh, 1997 and Dixit and Namgial, 2012) as it is not feasible practically to design equipment for an individual sex (male or female).

Anyone involved in agriculture may face challenges and are disabled in one way or the other to perform the desirable task. Also, there are several cases where a person was disabled because of injuries caused by the agricultural activities. As disability in border sense refers to a social, physical or mental condition that limits a person's movements, senses or activities, either a person may be disabled or the environment may be disabled to carry out the agricultural activities.

Gupta *et al.* (1983) reported that proper matching of machine requirements with the human capabilities is basically necessary for optimum performance of any man-machine system. Agricultural mechanization has increased considerably over the last few years in India, but little anthropometric data is available for looking into the ergonomic problems of mechanization in a particular region. Data of other countries cannot be used for design of farm machines in India because it can result in either an uneconomical design or a design with less efficiency due to improper matching of the operator and the machine. Thus anthropometric data available for other countries cannot be applied in India.

According to Philip *et al.* (2000) the relative high standard deviation, in general, shows the diversity in body dimensions of the subjects. The percentile values were logical in most of the design situations. In their study different body dimensions of the subjects were collected from 137 female workers and data were compared with that of male workers of the region as well as data of female workers from other ethnic groups. The survey suggested that devices and implements designed for these populations should be suitably modified before introducing it to the Indian farm workers.

Thus, one can define ergonomics as a science concerned with the 'fit' between people and their work. It puts people first, taking account of their capabilities and limitations. Ergonomics aims to make sure that tasks, equipments, information and the environment suit each worker.

## 2.7 PHYSIOLOGICAL RESPONSE OF SUBJECTS

The field studies recounted by Corlett and Richardson (1981) showed how poor working posture could lead to posture stress, fatigue and pain, which may in turn force the worker to stop work until the muscles recover. Although designer will have options to choose from 5<sup>th</sup>, 50<sup>th</sup> or 95<sup>th</sup> percentile values. Judicious selection should be made depending on the specific work situation.

Karunanithi and Tajuddin (2003) suggested that farm implements and machinery hitherto have not been ergonomically designed. Hence there was an urgent need to study the ergonomic aspects to quantify the drudgery involved in agricultural operations especially in rice farming. Both male and female subjects doing transplanting by manual and machine system were studied and found that male workers consumed 2 to 10 percent more energy than female workers for performing the same task. This might be attributed to the more weight of male workers than female workers.

Singh *et al.* (2010) in their 'Ergonomic Evaluation of farm women during maize shelling' concluded that maize sheller was the best option for the women as it saved not only the time but increases the efficiency of farm women twice and saved about 43 per cent cardiac cost of worker per unit of output in comparison to the hand shelling.

## 2.9 SUBJECT RATING OF PERCEIVED EXERTION

The physical methods included in this section can be used to obtain essential surveillance data for the management of injury risks in the workforce. It was generally accepted that many musculoskeletal injuries begin with the worker experiencing discomfort. If ignored, the risk factors responsible for the discomfort eventually will lead to an increased severity of symptoms, and what began as mild discomfort gradually become more intense and will be experienced as aches and pains. If left

unchecked, the aches and pains that signal some cumulative trauma eventually may result in an actual musculoskeletal injury, such as tendonitis, teno-synovitis, or serious nerve-compression injury like carpal tunnel syndrome.

Hedge (2004) claimed that discomfort will also adversely affect work performance, either by decreasing the quantity of work, decreasing the quality of work through increased error rates, or both. Reducing the levels of discomfort actually decreases the risk of an injury occurring. Consequently, changes in levels of discomfort can also be used to gauge the success of the design of an ergonomic product or the implementation of an ergonomic program intervention.

Musculoskeletal disorders (MSDs) were increasingly recognized as a significant hazard of agricultural occupation. In agricultural jobs with significant physical labor, MSDs are typically the most frequently reported injury. National Institute for Occupational Safety and Health (NIOSH) has identified MSDs as a priority area, and it specifically recommends reducing the incidence and prevalence of MSDs associated with work practice and production agriculture. One of the key challenges in this area pertains to measurement, due to the fact the musculoskeletal strain is a chronic condition that will be occurring for short duration, with self-reported pain as its only indicator.

Assessment of human strain in response to workplace stresses was an integral part of any ergonomic risk evaluation process. Strain assessment has relied on two types of outcome measures, namely, objective and subjective (Ljunggren, 1986).

Borg (1970) argued that perceived exertion was the 'single best indicator of the degree of physical strain'. He pointed out that perceived exertion rating integrated information from various signals, which described the reaction of physiological sources.

### **2.8.1 Overall Discomfort Rating (ODR)**

Postural limits to activity at work were defined by levels of acceptable pain in the muscles, identified by the use of a body part discomfort assessment (Corlett and

Bishop, 1976). The psychophysical measurement system in the study was a 10-point visual analogue discomfort (VAD) rating scale. The left end was marked as '0' representing no discomfort and right end was marked as '10' representing extreme discomfort.

Tiwari *et al.* (2005) conducted study in power tiller and found that the provision of an operator's seat reduced drudgery during its operation. It was found that from the ODR data of a 15-min trial at a speed of  $0.63 \text{ m s}^{-1}$  without the operator's seat, the mean rating was 3.0, which could have increased to extreme level with passage of time. Mean ODR at speed of  $0.62 \text{ m s}^{-1}$  with the operator's seat was 1.5.

Chauhan and Dayal (2012) have done postural analysis of farm women performing harvesting operation. The mean score of feeling of discomfort was maximum in upper arm and lower back followed by upper back, shoulder and neck. Thus, it was clear that these are the most adversely affected body parts of farm women performing weeding operation. Stooped posture was found to affect the ligaments and spinal muscles, increasing the spine's risk of injury.

### 2.8.2 Overall ease of operation rating (OER)

A 10 - point psychophysical rating scale (0 – very easy, 10 – extremely difficult) was used for the assessment of ease of operation.

The ergonomic study conducted by Mohanty *et al.* (2008) for farm women in manual paddy threshing and revealed that the pedal force required for single operator and double operators were  $232.3 \pm 7.0 \text{ N}$  and  $199.7 \pm 5.8 \text{ N}$  respectively, but was higher than the mean leg strength of the women of the eastern region of India. Higher pedal force application with double operators increased the number strokes  $\text{min}^{-1}$  ( $96 \text{ min}^{-1}$ ) leading to a 51.15 per cent increase in output capacity of the thresher per hour per person. An increase of length of the pedal by 2 cm was suggested to reduce the force requirement. The length of the threshing drum can be reduced from 60.5 cm to 40 cm to be used by single operator or it can be increased to 75 cm to comfortably accommodate two persons.



### 2.8.3 Overall safety Rating (OSR)

A 10 - point psychophysical rating scale (0 – completely secure and no fear, 10– Totally insecure and extreme fear) was used for the assessment of safety rating.

Rathod (2013) observed that direct seeder was completely secure with no fear and, mechanical transplanter was secured and meager in the ergonomic evaluation of direct paddy seeder and mechanical rice transplanter in wet lands.

Vahab (2015) had done subjective assessment of five different types of existing coconut climbing devices and claimed that the safety were less for standing type (Chemberi model) with scale as “Moderately secure and less fear”. Female subjects also shown the score of 5.2 with the scale of “Secure and meagre fear” for TNAU model, that might be due to its heavy weight. CPCRI model coconut climbing also showm scale as “Secure and meagre fear” with the score of 2.8 by male and 2 by female subjects. The safety rating were comparatively less for KAU coconut palm climbing device and CPCRI model coconut climbing device for both male and female subjects which means these two models were comparatively safe during operation.

### 2.8.4 Body part discomfort score (BPDS)

For identifying Body Part Discomfort Score (BPDS), the human body was divided into 12 regions. The number of different groups of body parts which are identified from extreme discomfort (10) to no discomfort (0) represented the number of intensity levels of pain experienced. The total score for a subject was the sum of all individual scores of the body parts assigned by the operator. The BPDS of all operators was averaged to get the main score.

Eminoglu *et al.* (2010) conducted study to determining postural discomfort at working with power tiller. It was concluded that the majority of perceived discomfort was indicated at lower arms, shoulders, thighs, legs and lower back respectively while operating power tiller. The most exertion was indicated at lower arms and shoulders for each tiller.

Meyer and Radwin (2007) used BPDS to find difference in body strain at stoop and prone posture for stimulated agricultural harvesting task. They found that body part discomfort score of working stoop posture was higher than working in prone posture.

Tewari *et al.* (2004) mounted a seat arrangement to detect physiological responses of the new seated position were compared with the effects of standard design where the operator must walk behind the machine, they found that work related body pain was reduced on an average 27% by incorporating a seat in the hand tractor. The appreciable reduction in pain was observed in the foot, thigh and back of the operator.

Carregaro *et al.* (2013) compared the work engagement and ratings of perceived exertion among healthcare workers. A body diagram was used and all participants were instructed to point out one or more body regions in which discomfort was present. The visual analog scale (VAS) was applied in order to quantify the magnitude of musculoskeletal discomfort. For the VAS, participants selected one body region that was, in their opinion, the most affected, and marked a point that best represented the intensity of discomfort in a line with exactly 10 cm (0 being no pain and 10 the worst pain ever). The VAS was measured in centimeters (cm), considering the demarcation of each individual. All subjects reported musculoskeletal complaints, mainly in the low back (58%).

*Materials and  
Methods*

## CHAPTER III

### MATERIALS AND METHODS

This chapter deals with the methodology adopted for the selection of subjects and the procedures followed for anthropometric measurements. The procedure followed for calibration of subjects and methodologies adopted for ergonomic evaluation of brush cutters are detailed. The complete descriptions and specifications of the brush cutters used for the study are also provided. Procedure followed for the development of vibration reducing aid, materials used and the method of evaluation adopted are also explained in the subsequent sessions.

#### 3.1 Selection of subjects

#### 3.2 Calibration of subjects

#### 3.3 Selection and specifications of brush cutter used for the study

#### 3.4 Hand Arm Vibration

#### 3.5 Development of vibration reducing aid

#### 3.6 Methods of evaluation

Mechanical vibrations in a machine are caused by the moving component of the machine. Every moving component has a certain frequency associated with its movement. Since, a machine may consist of many such moving component, the overall vibrations transmitted to the human body in contact with the machine are subjected to vibrations of different frequencies occurring simultaneously. The magnitude of vibration, frequency spectrum of vibration, the duration of vibration exposure per working day and cumulative exposure date are the most important variables for the risk assessment of hand-arm vibration. Two commonly used brush cutter models and six subjects (three male and three female) were also selected to conduct the study.

### 3.1 SELECTION OF SUBJECTS

Three trained male and female labours who were having more than 2 years of experience in brush cutter operations from K.C.A.E.T instructional farm were selected as the subjects for the study. The anthropometric dimensions of selected

subjects were confirmatory with the anthropometric dimensions of subjects selected by Vahab (2015).

### 3.1.1 Age and Medical Fitness

The subjects were verified for medical fitness by a registered medical practitioner. None of the subjects showed any symptoms of illness and nobody were handicapped. Details of the subjects and their work experience in years are presented in Table 3.1.

**Table 3.1 Age and experience of selected subjects**

Sl. No.	Subject code	Gender	Age	Experience
1	I	Male	63	>5 years
2	II		60	> 5years
3	III		59	> 3 years
4	IV	Female	42	>5 years
5	V		43	> 2 years
6	VI		43	> 2years

### 3.1.2 Anthropometry

Anthropometry is a branch of human science which deals with measurement of human body with respect to body marks. It may include data collection of linear dimensions, clearance, reach, posture, weight and volume. The standard proforma developed by AICRP on ESA, Bhopal, India was used for collecting data (Tewari, 2004). The subjects were informed with the objectives of the study, body dimensions, strength measurement procedures and clothing requirements before data collection. Thirty two different anthropometric dimensions pertinent to the brush cutter operation and hand arm vibration which were useful for the design of vibration reducing aid was identified, selected and enlisted (Table 3.2).

### 3.1.3 Anthropometric instruments

Anthropometric dimensions were measured by using instruments that used by Vahab (2015) during the study on evaluation of physiological cost and subjective assessment of existing coconut climbing devices. The anthropometric instruments available at the Ergonomic laboratory, Dept. of F.P.M.E., K.C.A.E.T., Tavanur

were used for collecting data. Details of the instruments used were depicted in Table 3.3,

**Table 3.2 Anthropometric dimensions used for the study**

Sl. No.	Anthropometric dimensions	Units	Sl. No.	Anthropometric dimensions	Units
1	Age	Year	17	Weight	kg
2	Hand thickness at metacarpal III	cm	18	First phalanx digit III length	cm
3	Stature	cm	19	Forearm hand length	cm
4	Eye height	cm	20	Palm length	cm
5	Acromial height	cm	21	Hand breadth	cm
6	Elbow height	cm	22	Maximum grip length	cm
7	Scapula to waist back length	cm	23	Hand breadth across thumb	cm
8	Illiocrystale height	cm	24	Index finger dimension	cm
9	Thumb tip reach	cm	25	Hand length	cm
10	Shoulder grip length	cm	26	Span	cm
11	Elbow grip length	cm	27	Span akimbo	cm
12	Hand breadth at metacarpal III	cm	28	Hand grip strength (right)	kg
13	Grip diameter (outside)	cm	29	Hand grip strength (left)	kg
14	Grip diameter (inside)	cm	30	Push strength (both hands) standing	kg
15	Middle finger palm grip diameter	cm	31	Pull strength (both hands) standing	kg
16	Hand thickness at metacarpal III	cm	32	Pinch strength	kg

**Table 3.3 Anthropometric instruments used for the study**

Sl. No.	Instrument name	Measurements possible
1	Integrated Composite Anthropometer	Measuring linear dimensions, diameters and clearances. Measuring hand strength parameters- pull and pull in seated and standing posture Weight-0-125kg
2	Baseline 300 Pound Digital Hand Dynamometer	Hand grip strength Range: 0-135 kg
3	Mechanical pinch gauge	Pinch strength
4	Baseline Lift dynamometer	Muscle strength

### ***3.1.3.1 Integrated Composite Anthropometer***

The integrated composite anthropometer consists of a base platform, backrest, sitting plank, horizontal and vertical supports and a handle support. Other support attachments of this equipment includes a 1m scale with free moving measuring tips for higher accuracy, a 0-100 kg spring balance, a 0-125 kg digital weighing balance, a multi hole finger diameter (13 mm to 24 mm) measuring device, a conical shape device for measuring internal grip diameter, a vernier for recording palm and hand measurements and measuring tapes.

This reliable and portable anthropometer can be used for measuring 75 anthropometric dimensions and five strength parameters, which having direct or indirect bearing on agricultural implements and machinery design (Gite and Chatterjee, 1999). The components of integrated composite anthropometer are presented in Plates 3.1 to 3.6

### ***3.1.3.2 Baseline 300 pound digital hand dynamometer***

The baseline hand dynamometer 300 pound capacity has accurate grip strength readings with LCD display. The five position adjustable handle can accommodate any handle size. An electronic zero calibration system and automatic shut off are also there. The strength readings can be viewed in pounds and kilograms. It can measure strength up to 135 kg. The baseline 300 pound hand dynamometer is shown in Plate 3.7.

### ***3.1.3.3 Mechanical pinch gauge***

The pinch gauge can be used to measure pinch strength. It is calibrated in pounds and kilograms of force. Apply pinch force at the pinch groove while holding the pinch gauge between thumb and finger(s). When force is applied farther toward the tip the reading will be slightly higher. When force is applied farther toward the rear the reading will be slightly lower. The gauge must be set zero before each pinch test. The red maximum pointer must be reset before each pinch test. Rotate the small knurled knob on top of the dial indicator in a counter clockwise direction until it resets against the black pointer at the zero marking. The mechanical pinch gauge is shown in Plate 3.8.



**Plate 3.1 Integrated Composite Anthropometer**



**Plate 3.2 Weighing balance**

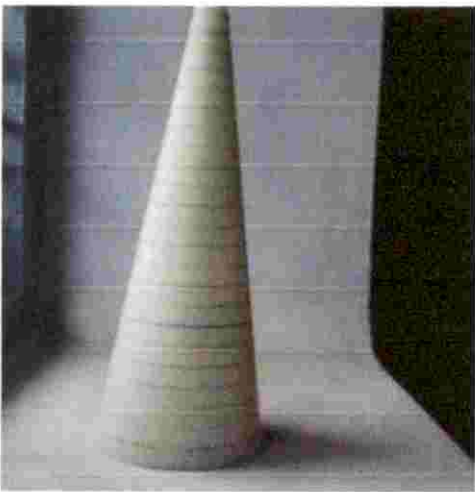

**Plate 3.3 Conical device for measuring internal grip**



**Plate 3.4 Skin fold diameter measuring device**



**Plate 3.5 Vernier calliper**

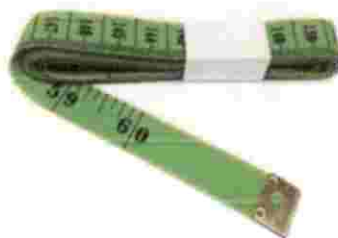

**Plate 3.6 Measuring tape**





**Plate 3.7 Baseline 300 pound digital hand dynamometer**



**Plate 3.8 Mechanical pinch gauge**

#### ***3.1.3.4 Baseline lift dynamometer***



**Plate 3.9 Baseline Lift dynamometer**

The Baseline back leg and chest dynamometer and cable tensiometer was used for muscle strength measurement. The unit can be used to measure strength of muscles of the back, leg and chest. The measurement base was provided with secure footing. Chain length was adjusted to accommodate for height differences

or to vary the point of force application. Maximum reading remained until the unit was reset. The strength reading can be viewed as pounds or kilograms. The Baseline Lift dynamometer is shown in Plate 3.9.

### **3.2 CALIBRATION OF SUBJECTS**

To evaluate the physiological workload using heart rate, the relationship between Heart Rate (HR) and Oxygen Consumption Rate (OCR) must be determined for each subject (Brockway, 1978 and Durnin, 1978). Both variables were measured in the laboratory at a number of sub maximal loads by varying the speed and inclination of belt of computerised treadmill. With linear relationship of the heart rate and the oxygen consumption, the OCR during the field trials was predicted from the calibration charts as reported by Bridger (1995).

The subject was tested with computerised treadmill with predetermined speed and with varying breaking loads. Standard protocol as explained was followed to record the OCR and the corresponding HR at different load conditions. The oxygen consumption was measured using Benedict-Roth Recording Spirometer and the heart beat rate was measured using Polar RS300X heart rate meter.

#### **3.2.1 Polar RS300X Heart rate meter**

The Polar RS300X training computer was used to record heart rate during training. The polar wear link transmitter sends the heart rate signal to the training computer. The transmitter consists of a connector and strap as shown in Plate 3.10. Before recording a training session was conducted in which the transmitter was wore by subject on wrist. The electrode areas of the strap were wetted well under running water. Then the connector was attached to the strap. Strap was tied around the chest just below the chest muscles in such a way that wet areas were firmly against the skin and polar logo of the connector was in central upright position. By using Polar flowlink and websync software heart rate reading was transferred to the computer.

#### **3.2.2 Benedict-Roth recording spirometer**

The BMR of the selected subjects was estimated by using Benedict- Roth recording spirometer shown in Plate 3.11.

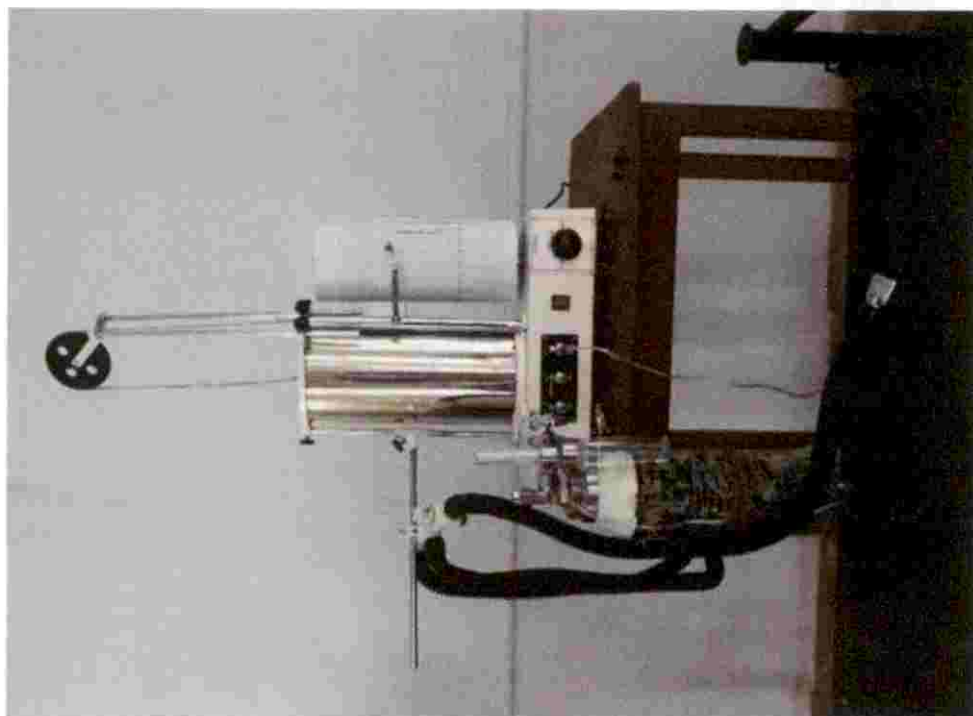

Plate 3.11 Benedict-Roth Recording Spirometer



3.10 Polar RS300X Heart rate meter

The apparatus consists of a 6 L spirometer with a speed strip chart recorder. The spirometer bell was hung by means of a chain and counter weighed over a pulley. The counter weight carried the light Perspex ink writing pen. The main base was made of aluminium casting with levelling screws. It housed the kymograph gear box, 3 stop cocks one to serve as water outlet and the other two for oxygen outlet. The two outlets provided on the left side of the base were connected to the stop cock. One of the outlet houses a rubber outlet valve and the other had provision to take a thermometer. The two way stop cock (breathing valve) was carried by an adjustable arm and fitted with a rubber mouth piece through corrugated rubber tubing. All air hoses were of 25 mm inside diameter. The speed of the spirometer was adjusted to  $20 \text{ min rev}^{-1}$  with the help of the speed selector.

### 3.2.3 Training of subjects

The subjects were trained in a treadmill. The treadmill is the better equipment for the calibration of the subjects than bicycle ergometer. The treadmill strains primarily lower body capacities but, in contrast to bicycling, the whole body weight must be supported and propelled by the feet. If the treadmill is inclined, the body must also be lifted. Hence the treadmill strains the body in a somewhat more complete manner than bicycling (Kroemer *et al.*, 1997). The use of handrail for support was avoided during running on the treadmill as the support reduces the maximum oxygen uptake and heart rate (Astrand, 1960). During the calibration, the subject had to run on the treadmill by inhaling the pure oxygen through Benedict-Roth spirometer. Subjects may feel uncomfortable in the initial stage but proper training makes the subject to get conversant with the equipment.

#### 3.2.3.1 VIVA FITNESS T1029 computerized treadmill

The VIVA FITNESS T1029 computerized treadmill consists of a walking belt track and the control panel as shown in Plate 3.12. Touch screen console displays every feedback of workout, including speed, inclination, elapsed time, distance, pace, time remaining and calories. Quick trigger buttons allows user to reach desire speed and incline with a simple hit. Heart rate monitoring is done by both hand pulse and telemetry. Easy navigation console panel and ergonomically designed

handle bar makes your access to the most-frequently used control with a push of the button. The specifications of VIVA FITNESS T1029 computerized treadmill is presented in Table 3.4



**Plate 3.12 VIVA FITNESS T1029 computerized treadmill**

**Table 3.4 Specifications of VIVA FITNESS T1029 computerized treadmill**

Particulars	Values
Speed	0.8 – 25 km h <sup>-1</sup>
Incline	0-15 level
Motor System	4.0 HP AC continuous (8.0 HP Peak) with efficient AC driving system
Running surface	56 cm x 157 cm
Maximum user weight	180 kg

### 3.2.4 Basal Metabolic Rate (BMR)

The basal metabolic rate of subject has to be measured before calibration. Energy expenditure of a subject in resting state is the basal metabolic rate of that subject. It is calculated by standard procedure using Benedict- Roth Recording Spirometer. This was measured when the subject was in post absorptive state shown in Plate 3.13. The subject was allowed to take rest for half an hour in a semi reclining position before the commencement of the test. Benedict- Roth Recording Spirometer bell was filled with oxygen from the storage oxygen cylinder. The mouth piece was connected to the apparatus safely and properly, and was fitted to the subject. Clip the nose of the subject with the help of nose clip. The subject was initially allowed to inhale atmospheric air for some time. After normalization of breathing rate, turn the saddle valve on to oxygen present in the spirometer bell. The subject inhales oxygen through the inspirating valve which was connected to the spirometer filled with oxygen and releases carbon dioxide through the expiratory valve coupled to carbon dioxide absorber. The kymograph records the oxygen consumption on the strip chart. From that chart choose a satisfactory uninterrupted section of exactly six minutes for computation of BMR. Oxygen consumed per 6 minute was corrected under standard temperature and pressure for calculation of BMR. The same procedure was repeated for all selected subjects.



**Plate 3.13 Measurement of BMR using Benedict-Roth Recording Spirometer**

The basal metabolic rate of the subject was measured by the procedure explained in **Computation of BMR (for male subject I)**

Room temperature, ° K	=	$T_2$
Room pressure, bars	=	$P_2$
Oxygen consumption for a period of 6 min, cc	=	$V_2$
Standard temperature, ° K	=	$T_1$
Standard pressure, bars	=	$P_1$
Oxygen consumed under standard temperature and pressure, L	=	$V_1 = \frac{P_2 \times V_2 \times T_1}{T_2 \times P_1}$
Energy produced in 6 min (E), kcal	=	$V_1 \times C$
Where C is calorific value of oxygen		
Energy per day, kcal	=	$\frac{E \times 60 \times 24}{6}$

*i.e.*, Basal Metabolic Rate, kcal day<sup>-1</sup>

### 3.2.5 Calibration process

Sanders and McCormick (1993) suggested the calibration of each person to determine the relationship between heart rate and oxygen consumption. For calibration of the selected subjects, Treadmill and Benedict-Roth Recording Spirometer were used simultaneously as shown in Plate 3.14. Before starting the experiment, all the subjects were properly trained for using the instruments separately and in combination.

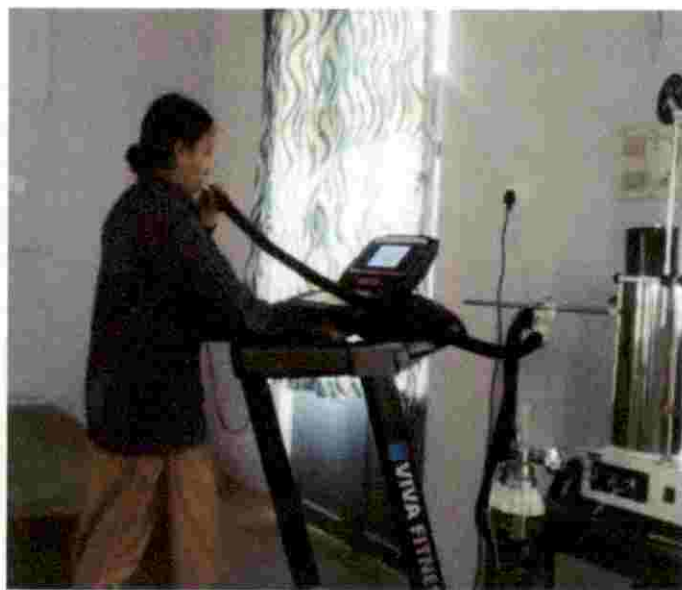

Plate 3.14 Calibration Process

The instrument operation was demonstrated to the subjects to familiarize them with the instruments so that they can use them without any tension and fear. The electrodes contained in the chest belt transmitter of polar heart rate monitor were wetted with water and fastened on the chest of the subject. The subject was allowed to take rest for half an hour in a semi reclining position before the commencement of the test. The Benedict-Roth spirometer was set up for calibration. The spirometer bell was filled with oxygen and the mouth piece is connected to the apparatus as well as to the subject. The oxygen consumption and heart rates were recorded simultaneously.

### 3.2.6 Maximum aerobic capacity ( $VO_2$ max)

The maximum aerobic capacity also called as maximum oxygen uptake capacity or  $VO_2$  max was conceived as an international reference standard of cardio-respiratory fitness (Gite and Singh, 1997). The  $VO_2$  max was the highest oxygen uptake attainable in the subject where a further increase in workload will not result in increased oxygen uptake (Rodahl, 1989). The acceptable workload (AWL) for Indian workers was the work consuming 35 per cent of  $VO_{2max}$  (Saha *et al.* 1979). To ascertain whether the operation of the selected implement was within the acceptable workload (AWL), it was necessary to compute the  $VO_2$  max for each subject. Because of the risk that involved in testing a person on a maximal energy task, various sub maximal tests have been advocated. The maximum heart rate attainable by the subjects was computed by following the relationship as suggested by Astrand (1960).

$$\text{Maximum heart rate} = 190 - (\text{Age in years} - 25) \times 0.62 \quad \dots 3.1$$

The intersection of the computed maximum heart rate of the subjects with the plotted calibration chart line and the line of fit to the oxygen uptake defines the  $VO_2$  max of the individual. The  $VO_2$  max for all the subjects was computed and recorded.

### 3.3 SELECTION AND SPECIFICATION OF BRUSH CUTTERS

Two widely used models of brush cutters one with two-stroke engine and the other with four-stroke engine which are available in the Dept. of Agrl. Engg., CoH were selected to study the hand arm vibration. The selected brush cutters were



Honda- GX31 having four-stroke engine and Redlands-RBC 252 having two-stroke engine. Commonly available four types of cutter heads were also selected during the study. The specifications of brush cutters and cutter heads used in the study are given in the Table 3.5. The dimensional sketch of 4 stroke brush cutter is shown in Figure 3.1.

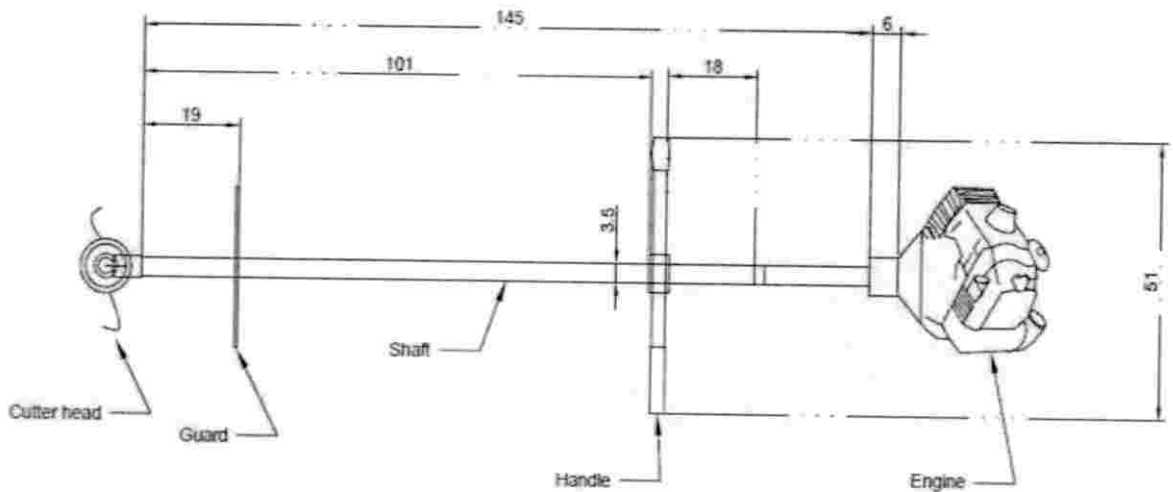

**Figure 3.1 Plan of the selected brush cutter with dimensions**

All dimensions are in cm

**Table 3.5 Specifications of brush cutters**

Sl. No.	Model	Honda (GX31)	Redlands (RBC 252)
1	Engine	4 stroke, single cylinder	2 stroke, single cylinder
2	Displacement	31 cc	51.7 cc
3	Power (max.)	1.1 kW @ 7000 rpm	1.7 kw
4	Torque (max.)	1.64 Nm @ 4500 rpm	2.6 Nm @ 4500 rpm
5	Starting	Recoil	Recoil
6	Cooling	Air cooling	Air cooling
7	Fuel	Gasoline	Gasoline+ Lubricating oil
8	Fuel tank	0.65 l	1.1 l
9	Total weight	7.03 kg	8.5 kg
10	Total length	1910mm	1915 mm
11	PTO shaft rotation	Counter clock wise	Counter clock wise

Four commonly used cutter heads were also selected and their specifications are listed in Table 3.6. and shown in Plates from 3.15 to 3.18.



Plate 3.15 Nylon rope cutter head



Plate 3.16 2-blade type cutter head



Plate 3.17 3-blade type cutter head



Plate 3.18 Circular type cutter head

Table 3.6 Specifications of cutter heads

Sl. No.	Cutter head	Specifications
1	Nylon rope	5.00 mm
2	2 blade type	305 mm × 25.4 mm × 2 T*
3	3 blade type	254 mm × 25.4 mm × 3 T*
4	Circular type	255 mm × 1.25 mm × 30 T*

\* Diameter × width × number of teeth

### 3.4 HAND ARM VIBRATION

Brush cutter is sustained by human operator on his shoulders and in the same time on his right foot and controls it with hands. Human operator's position for the trimming operation is standing and little bended forward. While operating brush cutters, certain amount of vibration is transmitted to human body. Human spine is

exposed to vibrational wave from two directions: from shoulders direction and from the right feet direction.

### 3.4.1 Vibration measurement

Magnitude and frequency of vibration are important for hand transmitted vibrations. Vibration measurement was carried out using accelerometer. The accelerometer orientation and locations were in accordance with the handle design as shown in Figure 3.2 and 3.3. The position of the accelerometer shall be as near as possible to the hand, without obstructing the normal grip. For brush cutter, the position should be opposite to the thumb (the inner side of the handle) when holding the machine in a normal working position. Measurements were carried for both brush cutters with all the four selected cutter heads.

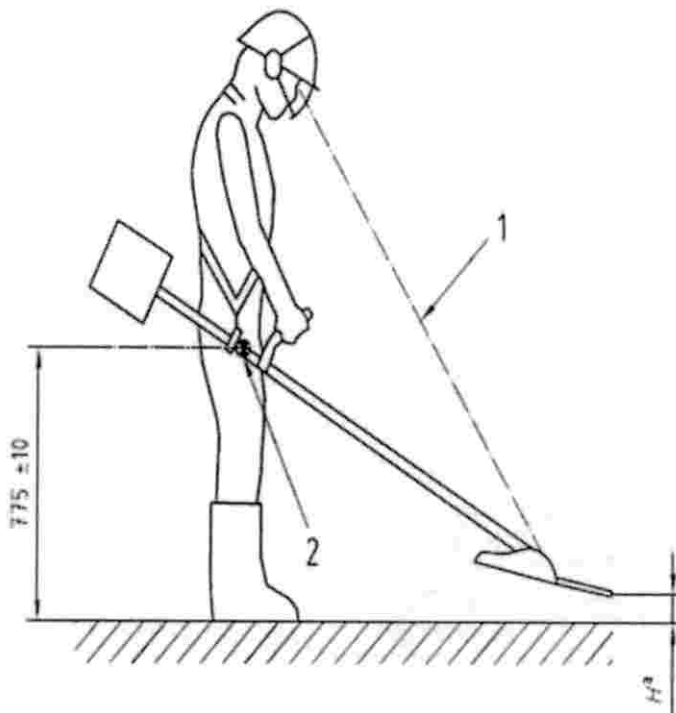

**Figure 3.2 Operating position of brush cutter**

1. Operator's view towards the cutting tool
2. Centre of gravity

$H^a = 300 \text{ mm} \pm 25 \text{ mm}$  for brush cutters and  $50 \text{ mm} \pm 25 \text{ mm}$  for grass trimmer

(Source: EN ISO 22867)

The operational speed selected for the study is 133 per cent the speed of maximum power is accordance to ISO 8893

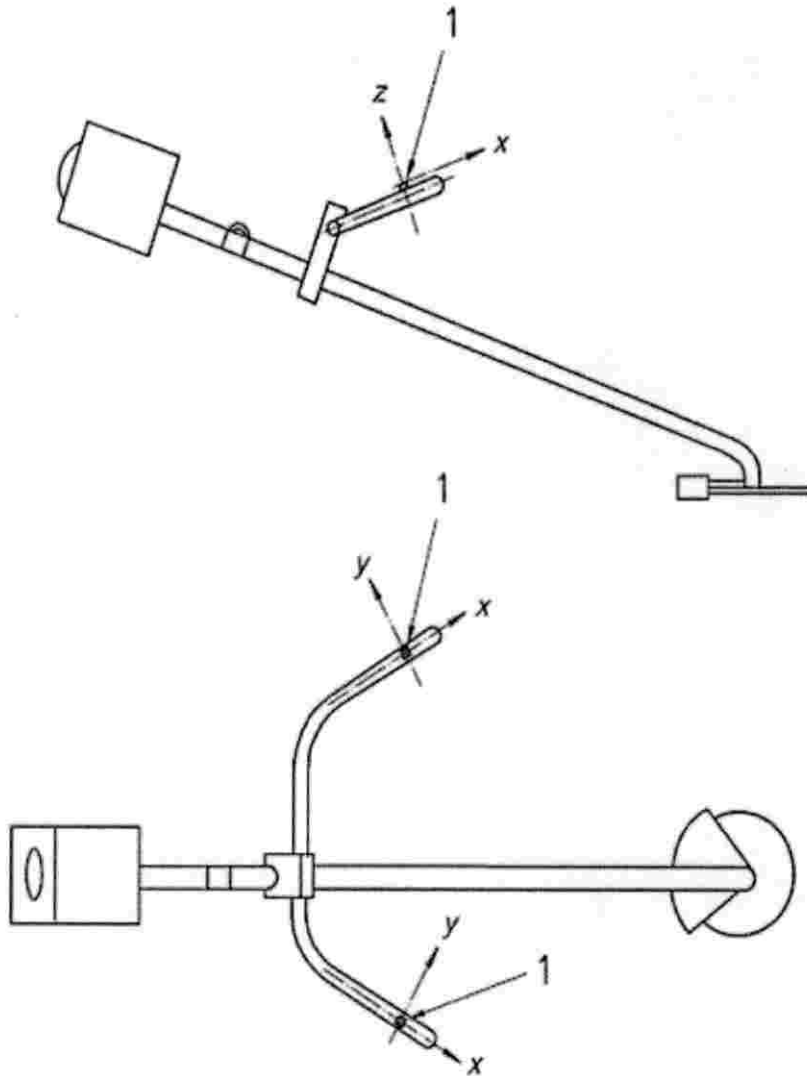

**Figure 3.3 Measurement direction and position of fastening of accelerometers on machines with right and left handle**

(Source: EN ISO 22867)

### 3.4.2 Instrument for vibration measurement

VB-8201HA vibration meter was used for measuring vibration at handles of brush cutter (Plate 3.19). The instrument consists of an accelerometer which was attached to the handles of the brush cutters and measurements were taken for two

brush cutters with and without vibration reducing aid. The specification of VB-8201HA Vibration meter is illustrated in Table 3.7.

**Table 3.7 Specification of VB-8201HA vibration meter**

Item	Specifications
Display	61 mm×34 mm LCD display
Measurement	Velocity, Acceleration, RMS value, Peak value, Data hold, Max. & Min. value
Range	Velocity: 200mm s <sup>-1</sup> ; 0.5 to 199.9 mm s <sup>-1</sup> Acceleration :200mm s <sup>-2</sup> ; 0.5 to 199.9 mm s <sup>-2</sup>
Frequency range	10 Hz to 1 KHz
Calibration point	Velocity : 50 mm s <sup>-1</sup> (160 Hz) Acceleration : 50 mm s <sup>-2</sup> (160 Hz)
Sampling time	Aprox. 1 second
Operating temperature	0° C to 50°C
Operating humidity	Less than 80 % RH



**Plate 3.19 VB-8201HA Vibration meter**

The hand arm vibration at the handles of the brush cutter were measured by using VB-8201HA vibration meter. The accelerometer is attached to the handles of the brush cutters through magnetic fixtures and measurements were taken for

two brush cutters without vibration reducing aid as explained in section 3.5.1. The frequency range was chosen 10 Hz to 1 KHz as hand arm vibration usually occur in the range of 100 to 250 Hz in brush cutter. The position of the accelerometer were as near to the hand, without obstructing the normal grip. The location and orientation of VB-8201HA vibration meter followed as per ISO-22867. The fastening of VB-8201HA vibration meter to the handles which is shown in Plate 4.1. The VB-8201HA vibration meter measured hand arm vibration in terms of acceleration. The data obtained as peak value and RMS values of acceleration was noted.

### **3.5 DEVELOPMENT OF VIBRATION REDUCING AID**

Design of vibration reducing aid was done by considering the ergonomic factors to reduce the fatigue of work by increasing comfort and safety. Based on ergonomic evaluation and subject's feedback, ODR, OSR, OER and BPDS a suitable vibration reducing aid was designed and developed. The developed vibration reducing aid attached to the brush cutter shaft and vibration readings were taken. The subjective rating and feedback of subjects were also noted.

#### **3.5.1 Conceptual design of vibration reduction aid for brush cutters**

Main objective of developing a vibration reducing aid for brush cutter was, it has to transmit a part of the vibration produced by the cutter head to the ground so that vibration will not transmit to the hands of the operator. The functional requirements considered for the development of such an aid is furnished below.

- i. It should be capable of transmitting at least a part of the vibration produced at cutter head to the ground.
- ii. It should be easily attached to or detached from the brush cutter shaft
- iii. There should be proper contact between the vibration reducing aid and the ground during operation. But it could be easily moved along with the cutter heads.
- iv. Provisions for fixing the vibration reducing aid at different positions on the brush cutter shaft may be there to enable changing of cutter head height with respect to the ground.

- v. The design should be symmetric with respect to the brush cutter shaft to ensure uniform distribution of vibrations to both sides of the brush cutter.
- vi. The position of ground contact points of vibration reducing aid and cutter head may be at a safe distance so that no obstruction is there when using different cutter heads.
- vii. The material used for the vibration reducing aid should be light in weight and sturdy, so that it could be raised easily along with the cutter head by the operator.

### 3.5.2 Development of a vibration reducing aid

According to the conceptual design, a vibration reducing aid was developed with the following.

1. Curved arm: MS square tube sections are used for the arm. It was curved in two directions X-plane and Y- plane so that it can be brought near to the cutter head, but at safe distance. The dimensional design sketch is provided in Figure 3.4.
2. Fixture to arm: The fixing end of curved arm is fixed to a fixture made of half pipe sections suitable to the diameter of brush cutter shaft. Provisions for fixing couplings to the arm to the cutter shaft is also made on the fixture.
3. Rubber grip: Rubber pads of circular cross sections suitable to cutter shafts are used between the arm fixture and shaft.
4. Quick fixing lock: Two quick fix coupling available in the market is used to the arm fixture to the cutter shaft. The coupling can be easily locked and unlocked with the help of screws provided.
5. Ground contact rollers and roller fixture: The ground contact of curved arms are provided with rubber rollers. The rollers are attached to the arm by using a fixture using nuts and bolts. The rubber rollers rotates 360° in horizontal with the brush cutter head. All the components of the vibration reducing aid plane enables the movement of ground contact points in any direction along with the brush cutter head. Dimensional sketch of vibration reducing aid is Figure 3.4 and Figure 3.5. All the components of vibration reducing aid is shown in Plate 3.20.

G3

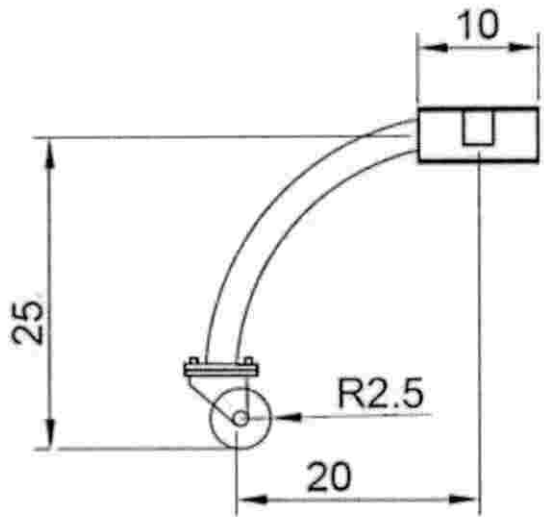

All dimensions are in cm

Figure 3.4 Side view of vibration reducing aid

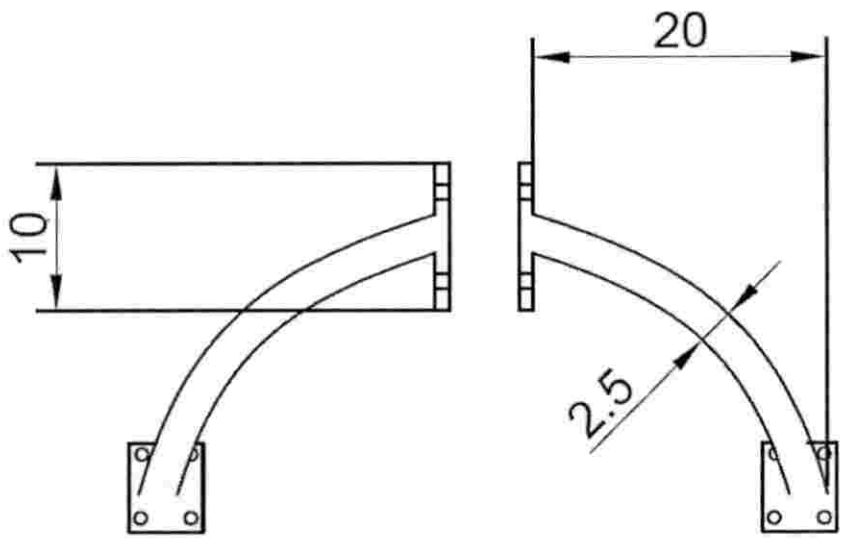

All dimensions are in cm

Figure 3.5 Plan of vibration reducing aid



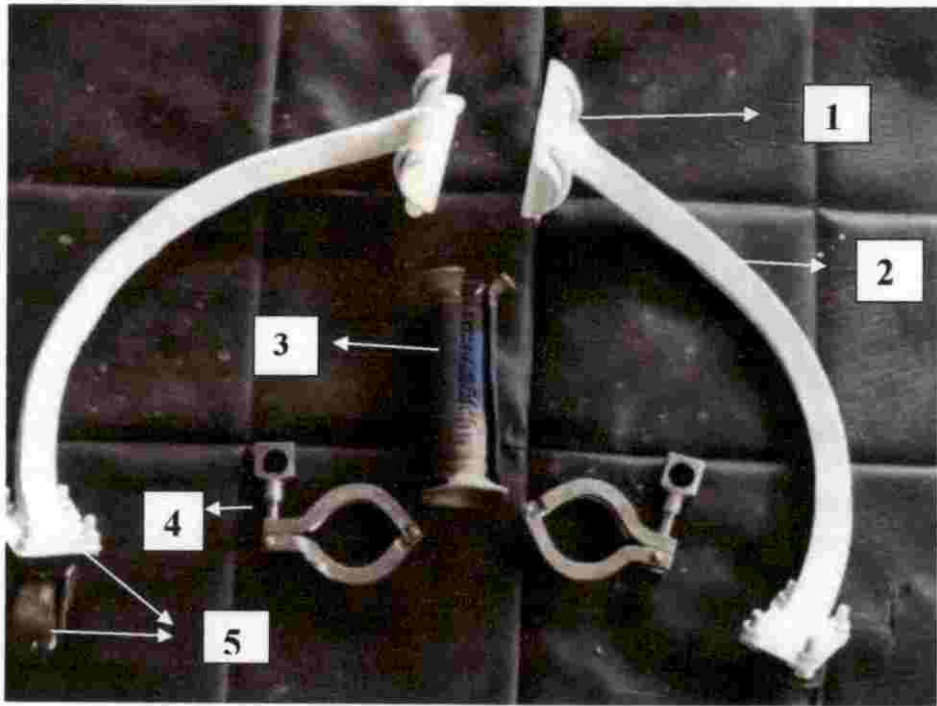

**Plate 3.20 Developed vibration reducing aid**

The developed vibration reducing aid was attached to the brush cutter in way that the cutter head was parallel to the ground and cutter head at a height of 5cm from the ground as per EN ISO 22867. The plan of the brush cutter attached with developed vibration reducing aid is given Figure 3.6. The side view of developed vibration reducing aid is given Figure 3.6. The side view of developed vibration reducing aid attached to brush cutter is presented in Figure 3.7.

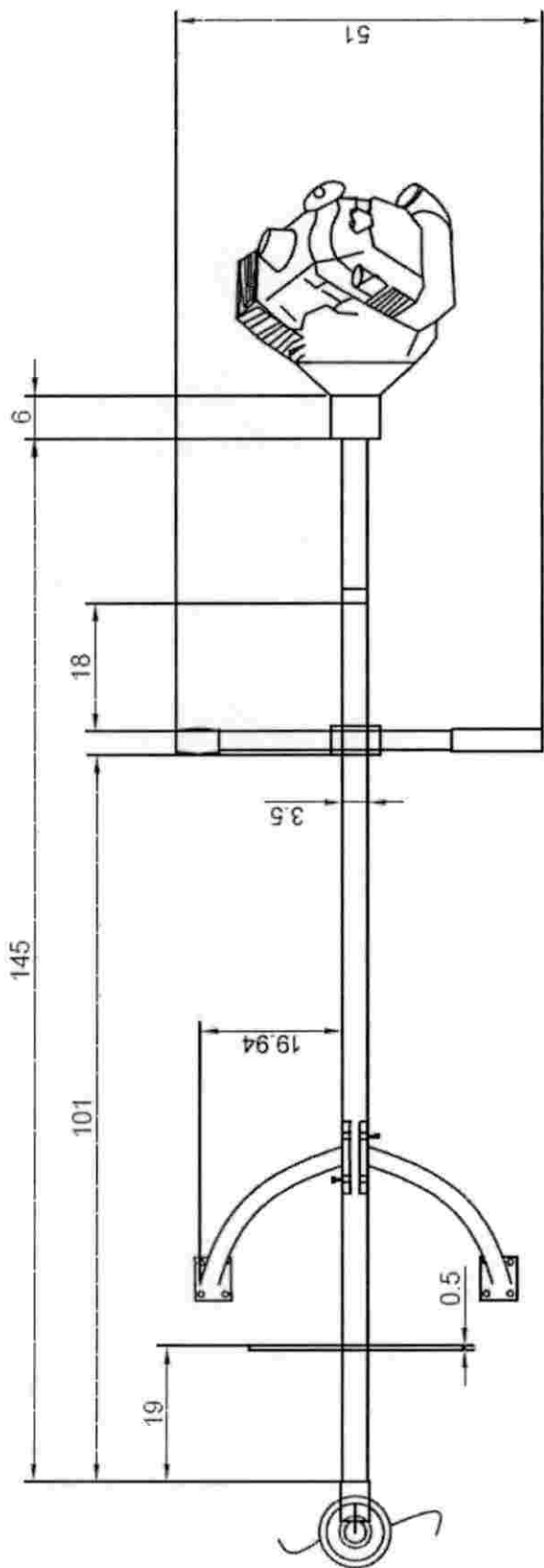
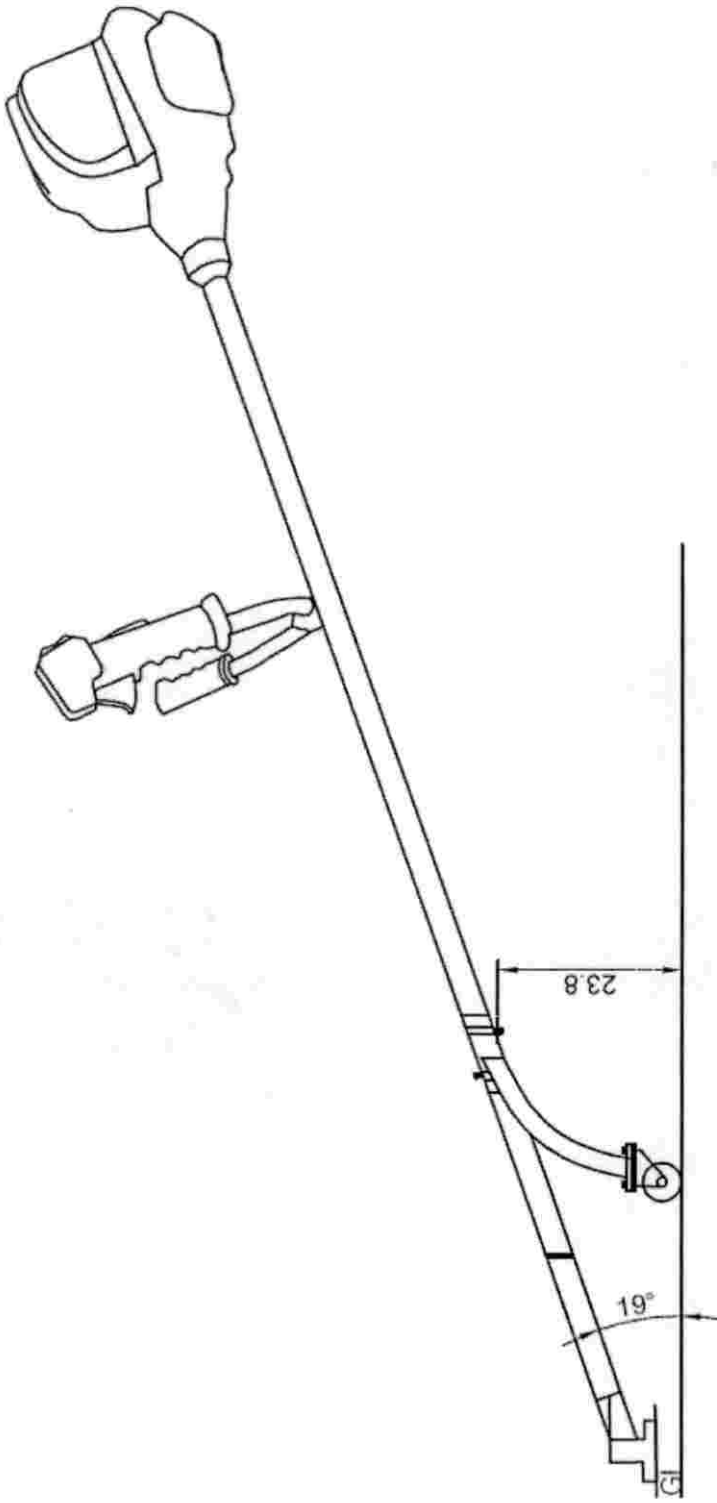

Figure 3.6 Plan of developed vibration reducing aid attached to the brush cutter shaft

All dimensions are in cm



All dimensions are in cm  
**Figure 3.7 Side view of developed vibration reducing aid attached to brush cutter shaft**

### 3.5.3 Experimental design

The performance of developed vibration reduction aid was evaluated in the field situated at K.C.A.E.T., Tavanur with male and female subjects. Variables considered for the study were brush cutter, cutter heads and vibration reducing aid

Brush cutter: Four- stroke engine (4S) and Two- stroke engine (2S)

Cutter heads: Nylon rope (N), 2-blade type (B2), 3 blade type (B3) and Circular blade type (C)

Vibration reducing aid: without attachment (NA) and attachment (A)

Subjects: Male (I, II, III) and Female (IV, V, VI)

**Table 3.8 Experimental design**

Treatment	Combinations
T1	4S N NA
T2	4S B2 NA
T3	4S B3 NA
T4	4S C NA
T5	2S N NA
T6	2S B2 NA
T7	2S B3 NA
T8	2S C NA
T9	4S N A
T10	4S B2 A
T11	4S B3 A
T12	4S C A
T13	2S N A
T14	2S B2 A
T15	2S B3 A
T16	2S C A

Total three replications were taken for male and female subjects.

The total size of data =  $16 \times 2 \times 3 = 96$

### 3.6 METHOD OF EVALUATION

Three male and three female subjects who are familiar with models of brush cutter operation are selected for field evaluation. All subjects were provided with proper protective clothing and all required information about the experiment. The heart rate of subjects during the brush cutter operation with the vibration reducing aid are recorded by using polar heart rate meter. The procedure of measurement is explained in section 3.3.1

As per standards, a minimum of ten per cent of working time is allotted as rest time in between two consecutive operations. Accordingly the subjects allowed to take rest for 5 minutes and instructed to work with brush cutter for 25 minutes. The four types of cutter heads were used in both two-stroke brush cutter and four-stroke brush cutters. The vibration at both handles and heart rate were recorded simultaneously. By using Polar flowlink and websync software heart rate reading was transferred to the computer. The vibration reducing aid were attached to brush cutter by using quick fixing lock. The vibration reducing aid attached to the brush cutter in the field is shown in Plate 4.21.



**Plate 3.21** Vibration reducing aid attached to brush cutter

### 3.6.1 Statistical analysis

Significance of various parameters like developed vibration reducing aid, type of cutter head and stroke over the excitation of vibration at both handle was analysed using the standard programme of MSTAT for Factorial Completely Randomised Design (FCRD) with vibration data values of for six subjects. Significance of the treatments was ascertained by analysing the probability value

(P value) of the test. If P less than 0.05, the treatment is significant at 5 per cent level of significance. Whenever P less than 0.01, the treatment was identified as highly significant *ie.* at 1 per cent level of significance. If P greater than 0.05, then the treatment was considered as not significant. Based on this, the significance of parameters were discussed.

### 3.6.2 Subjective Rating

In ergonomic study perceived exertion by operators was determined with Overall Discomfort Rating (ODR), Overall Ease of operation rating (OER), Overall Safety Rating, and Body Part Discomfort Score (BPDS).

#### 3.6.2.1 Overall Discomfort Rating (ODR)

The trials for discomfort rating for selected brush cutters with attachment were carried out in field condition. Overall discomfort rating (ODR) shall be measured on a 10-point visual analogue scale (0- no discomfort, 10- extreme discomfort) that is an adoption of a technique developed by Corlett and Bishop (1976). At the end of each trial, the subjects were asked to indicate their overall discomfort rating by putting '✓' mark on scale shown in Table 3.9

**Table 3.9 Overall discomfort rating (ODR)**

No discomfort	Light discomfort		Moderate discomfort		More than moderate		Very uncomfortable		Extreme discomfort		
	0	1	2	3	4	5	6	7	8	9	10

The discomfort rate is indicated by each subject is added together and average is taken as Overall Discomfort Rating of that operation.

#### 3.6.2.2 Overall Safety Rating (OSR)

A 10 – point psychophysical rating scale (0 – completely secure and no fear, 10 – Totally insecure and extreme fear) was used for the assessment of safety rating, which is adoption of Corlett and Bishop (1976) technique. A scale as shown in Table 3.10 was prepared having 0 to 10 digits equidistantly. At the ends of each trial, subjects were asked to indicate their safety rating on the scale by using a pen. The safety ratings given by subjects were found out and analysed to interpret the results.

**Table 3.10 Overall safety rating (OSR)**

Completely secure and no fear	Secure and meager fear		Moderately secure and less fear		Slightly secure and moderate fear		Insecure and more fear		Totally insecure and extreme fear	
	1	2	3	4	5	6	7	8	9	10
0										

### 3.6.2.3 Overall ease of operation Rating (OER)

For the assessment of ease of operation, a 10 - point psychophysical rating scale (0 -very easy, 10 – extremely difficult) was used, which is adoption of Corlett and Bishop (1976) technique. A scale as shown in Table 3.11 having 0 to 10 digits marked on it equidistantly was prepared. At the ends of each trial subjects were asked to indicate their ease of operation rating on scale by using a pen.

**Table 3.11 Overall ease of operation rating**

Very easy	Easy		Less difficulty		Difficult to operate		Very difficult		Extremely difficult	
0	1	2	3	4	5	6	7	8	9	10

### 3.6.2.4 Body Part Discomfort Score (BPDS)

BPDS is a subjective method for direct ascertainment of aware discomfort. A tool used for analysing workplace activities in Body Part Discomfort Form. Such forms are based on the principle that the static loads (static work) involved in a given activity can be assessed by measuring the muscular pain experienced. Identifying the level and location of the pain permits a direct evaluation of the activities performed.

In the Corlett and Bishop (1976) technique, subject's body is divided into 27 regions. Regions of body map for evaluating BPDS is given Figure 3.8. The subject was asked to mention all body parts with discomfort, starting with worst, second worst and so on until all parts have been mentioned (Lusted *et al.*, 1994). The subject was asked to write '1' on the body part for maximum pain, '2' for next maximum pain experienced and so on. The number of different groups of body parts which are identified from extreme discomfort to no discomfort represented the number of intensity level of pain experienced.

The maximum numbers of intensity levels of pain experienced for the operation of equipment were categorized. The rating will assigned to these categories in an arithmetic as order as explained below viz., if the maximum number of intensity levels of pain experienced for the operation was six categories, first category (body parts experiencing maximum pain) rating was maximum 6 and for second category (body parts experiencing next maximum pain) rating was allotted as 5 and so on. For the sixth category (body parts experiencing least pain) rating was allotted as 1. The number of intensity levels of pain experienced by different subject might be varying.

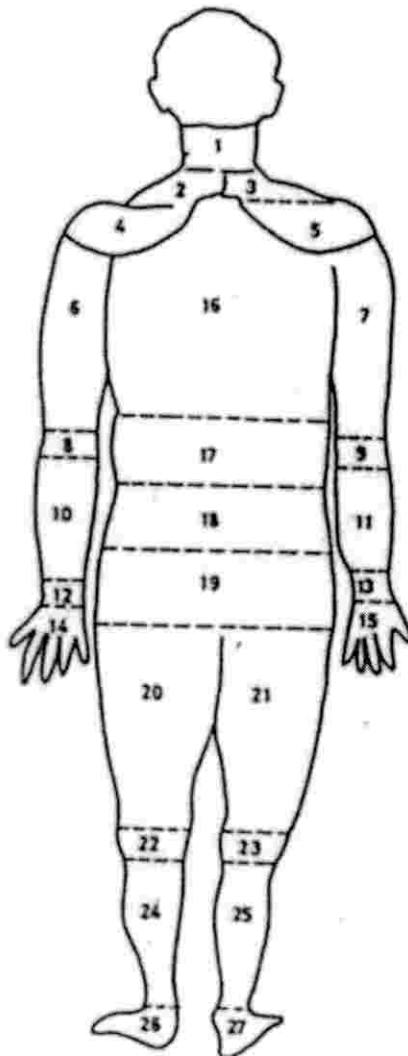

Figure 3.8 Regions for evaluating BPDS



*Fo2*

1	Neck	15	Right palm
2	Clavicle left	16	Upper back
3	Clavicle right	17	Lower back
4	Left shoulder	18	Buttocks
5	Right shoulder	19	Left thigh
6	Left arm	20	Right thigh
7	Right arm	21	Left knee
8	Left elbow	22	Right knee
9	Right elbow	23	Left leg
10	Left forearm	24	Right leg
11	Right forearm	25	Right foot
12	Left wrist	26	Left foot
13	Right wrist	27	Right foot
14	Left palm		

(Source: Corlett and Bishop, 1976)

*Results and  
Discussion*

## CHAPTER IV

### RESULT AND DISCUSSION

This chapter deals with the analysis of anthropometric data, calibration process and computed values of oxygen consumption and energy cost during the operation of brush cutter with different cutter heads. The overall discomfort rating, overall safety rating, overall ease of operation rating, body parts discomfort scores were measured and discussed. Hand arm vibration at handles of brush cutter without and with attachment were measured and analysed. Oxygen consumption, energy cost, overall discomfort rating, overall safety rating, overall ease of operation rating and body parts discomfort scores of brush cutter operation were found out and detailed.

#### 4.1 SELECTION OF SUBJECTS

Three male and female subjects each were selected having experience in brush cutter operation as explained in section 3.1.

#### 4.2 ANALYSIS OF ANTHROPOMETRIC DATA

The Anthropometric data as per Gite *et al.* (2009) of three male and female subjects each were collected at laboratory conditions by using anthropometer as explained in section 3.2.3. The anthropometric dimensions and strength data of subjects are presented in Table 4.1 and 4.2.

#### 4.3 CALIBRATION OF SUBJECTS

All male and female subjects were calibrated by indirect assessment of oxygen uptake using Benedict-Roth Spirometer. The heart rate of subjects were recorded using heart rate meter at sub maximal loads while running on the computerized treadmill to arrive the relationship between the heart rate and oxygen consumption. Heart rate and oxygen consumption were measured as explained in section 3.3.

**Table 4.1 Anthropometric dimensions of subjects**

Sl. No.	Anthropometric dimensions	Subjects					
		Male			Female		
		I	II	III	IV	V	VI
1	Age	63	60	59	42	43	43
2	Weight (kg)	54.60	54.10	57.40	49.60	55.20	54.20
3	Stature	165.50	155.00	157.60	143.80	145.70	148.50
4	Eye height	155.20	143.50	145.80	133.10	133.60	137.30
5	Acromial height	137.50	127.00	129.90	118.60	122.10	121.90
6	Elbow height	109.00	93.80	97.60	88.90	93.50	83.10
7	Scapula to waist back length	54.00	48.00	52.10	55.00	52.20	57.50
8	Illiocrystale height	96.00	87.10	88.20	85.80	96.50	87.30
9	Thumb tip reach	81.50	77.50	72.60	65.80	70.80	75.60
10	Shoulder grip length	68.00	63.30	68.50	55.60	67.40	60.80
11	Elbow grip length	45.50	34.20	30.60	29.10	32.70	28.90
12	Hand length	16.30	14.50	15.60	15.50	15.80	18.20
13	Grip diameter (outside) – right hand	6.80	7.60	7.50	6.60	6.50	7.10
14	Grip diameter (Inside) – right hand	3.10	3.10	3.20	3.30	3.30	4.00
15	Middle finger palm grip diameter	2.60	2.60	2.40	2.40	2.50	2.80
16	Hand thickness at metacarpal III	2.40	2.50	2.20	2.60	2.30	2.80
17	First phalanx digit III length	5.10	6.30	5.70	5.80	5.60	6.10
18	Forearm hand length	40.30	38.50	41.50	40.80	38.10	40.80
19	Palm length	8.30	7.90	8.60	9.10	8.20	9.90
20	Hand breadth across thumb	8.70	8.60	8.30	7.90	8.10	9.00
21	Maximum grip length	13.60	8.90	9.30	11.90	9.60	12.60
22	Index finger dimension	2.00	1.70	1.90	1.90	1.80	1.80
23	Hand breadth	8.00	7.80	7.50	7.00	6.70	7.70
24	Span	164.50	165.50	167.00	155.50	151.20	15.40
25	Span akimbo	91.00	88.00	85.00	83.00	80.50	81.10

(Unit: cm unless otherwise specified)

**Table 4.2 Anthropometric strength measurements of selected subjects**

Sl. No.	Strength measurements	Subjects					
		I	II	III	IV	V	VI
1	Hand grip strength (right)	30	33	34	10	11.30	11.30
2	Hand grip strength (left)	26	28	27	8.6	8.6	8.6
3	Push strength (both hands) standing	70	74	75	23.50	29.50	28.12
4	Pull strength (both hands) standing	>100	>100	>100	>100	43	43
5	Right hand push strength	48	50	60	48	50.1	55
6	Right hand pull strength	70	64	68	39	75.4	66
7	Pinch strength	4	4	4	1	2.2	2
8	Arm lift	60	110	70	10	20	10

(Unit: kg)

**4.3.1 Heart rate (HR)**

Heart rate of each subject were recorded at one minute interval for six minutes for preparing the calibration chart. The corresponding oxygen consumption rate were also measured and the data is presented in the Table 4.3.

**Table 4.3 Heart rate and oxygen consumption of subjects during calibration**

Time (min)	Subjects											
	I		II		III		IV		V		VI	
	HR	VO <sub>2</sub>	HR	VO <sub>2</sub>	HR	VO <sub>2</sub>	HR	VO <sub>2</sub>	HR	VO <sub>2</sub>	HR	VO <sub>2</sub>
1	72	0.520	73	0.500	75	0.620	78	0.450	72	0.410	73	0.480
2	85	0.780	86	0.660	95	0.860	85	0.620	82	0.490	84	0.510
3	92	0.820	92	0.700	102	0.980	96	0.750	95	0.580	98	0.590
4	103	0.960	110	0.820	114	1.150	108	0.800	103	0.630	107	0.670
5	113	1.020	125	1.020	127	1.200	115	0.890	116	0.710	122	0.790
6	127	1.140	130	1.320	135	1.340	128	0.950	124	0.890	130	0.910

Heart rate (beats min<sup>-1</sup>)**4.3.2 Basal Metabolic Rate**

Basal metabolic rate (BMR) of all subjects were measured by the procedure explained in the section 3.2.4 by using computerised treadmill and Heart rate meter. BMR is calculated and explained.

$$\begin{aligned}
 \text{Room temperature (T}_2\text{), }^\circ\text{K} &= 63 \\
 \text{Room pressure (P}_2\text{), bars} &= 50.6 \\
 \text{Oxygen consumption for a period of 6 min (V}_2\text{), cc} &= 1.65 \\
 \text{Standard temperature (T}_1\text{), }^\circ\text{K} &= 273 \\
 \text{Standard pressure (P}_1\text{), bars} &= 1.0325 \\
 \text{Oxygen consumed under standard temperature and} & \\
 \text{pressure, L} &= \frac{P_2 \times V_2 \times T_1}{T_2 \times P_1} \\
 &= \frac{0.99 \times 1.610 \times 273}{303 \times 1.0325} \\
 &= 1.3909 \\
 \text{Energy produced in 6 min, kcal} &= 1.3909 \times 4.832 \\
 &= 6.7207 \text{ kcal} \\
 \text{Energy per day, kcal} &= \frac{6.720 \times 60 \times 24}{6} \\
 \text{i.e. Basal Metabolic Rate, kcal day}^{-1} &= 1612.98
 \end{aligned}$$

76

Similarly BMR of all subjects were calculated and the results are presented in the Table 4.4

**Table 4.4 Measured BMR of six subjects**

Sl. No.	Subjects	Gender	Oxygen consumption for 6 minutes (l)	BMR(kcal/day)
1	I	Male	1.3908	1612.980
2	II		1.1230	1302.406
3	III		1.0798	1252.314
4	IV	Female	0.8379	971.793
5	V		0.6997	811.499
6	VI		0.8207	951.758

It is observed that the oxygen consumption and BMR is higher for male subjects compared to female subjects. Highest value of O<sub>2</sub> consumption and BMR obtained is for subject I (1.3906 l and 1612.980 kcal day<sup>-1</sup>). The lowest value obtained is for female subject V (O<sub>2</sub> consumption of 0.6997 l and BMR of 811.499 kcal day<sup>-1</sup>).

### 4.3.3 Calibration chart

Astrand and Rodhal (1977) found in their study that there existed a linear relationship between the oxygen consumption and heart rate during calibration. Accordingly a calibration chart was prepared with heart rate as the ordinate and the oxygen uptake as the abscissa for the selected six subjects.

The linear equations showing the relationship between the two parameters (heart rate; X and Oxygen consumption; Y) according to the calibration chart for each subjects in presented in the Table 4.5.

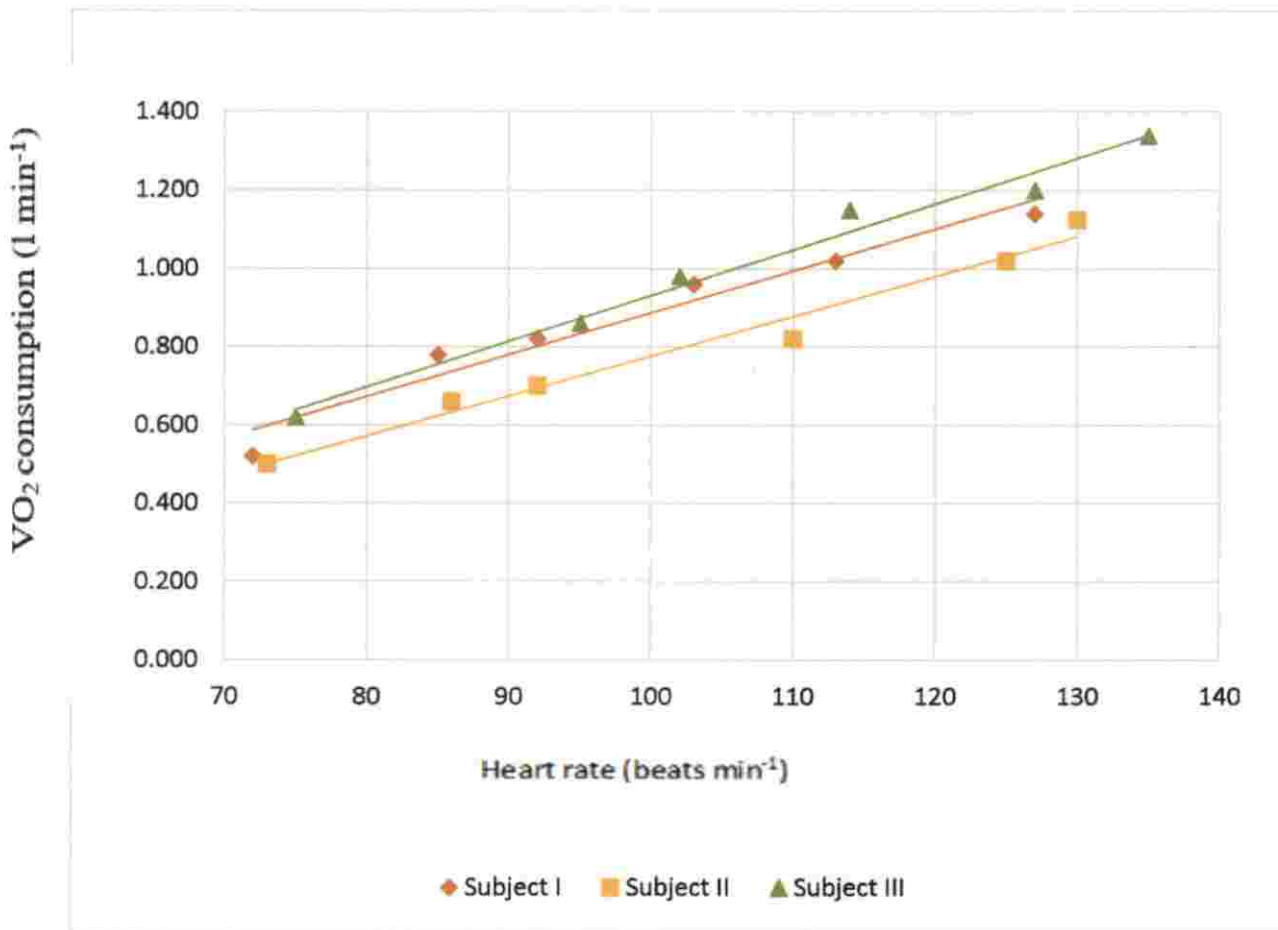

Figure 4.1 Calibration chart for oxygen consumption of male subjects

VO<sub>2</sub> consumption (l min<sup>-1</sup>)

Figure 4.2 Calibration chart for oxygen consumption of female subjects

Table 4.5 Linear equation showing relationship between the heart rate(X) and oxygen consumption(Y) of subjects

Sl. No.	Subject	Gender	Linear equation	R <sup>2</sup> value
1	I	Male	$Y=0.0170X-0.1831$	$R^2=0.9546$
2	II		$Y=0.0123X-0.424$	$R^2=0.9001$
3	III		$Y=0.0117X-0.0814$	$R^2=0.9703$
4	IV	Female	$Y=0.0094X-0.2107$	$R^2=0.9297$
5	V		$Y=0.0083X-0.2037$	$R^2=0.9484$
6	VI		$Y=0.0075X-0.1063$	$R^2=0.9578$

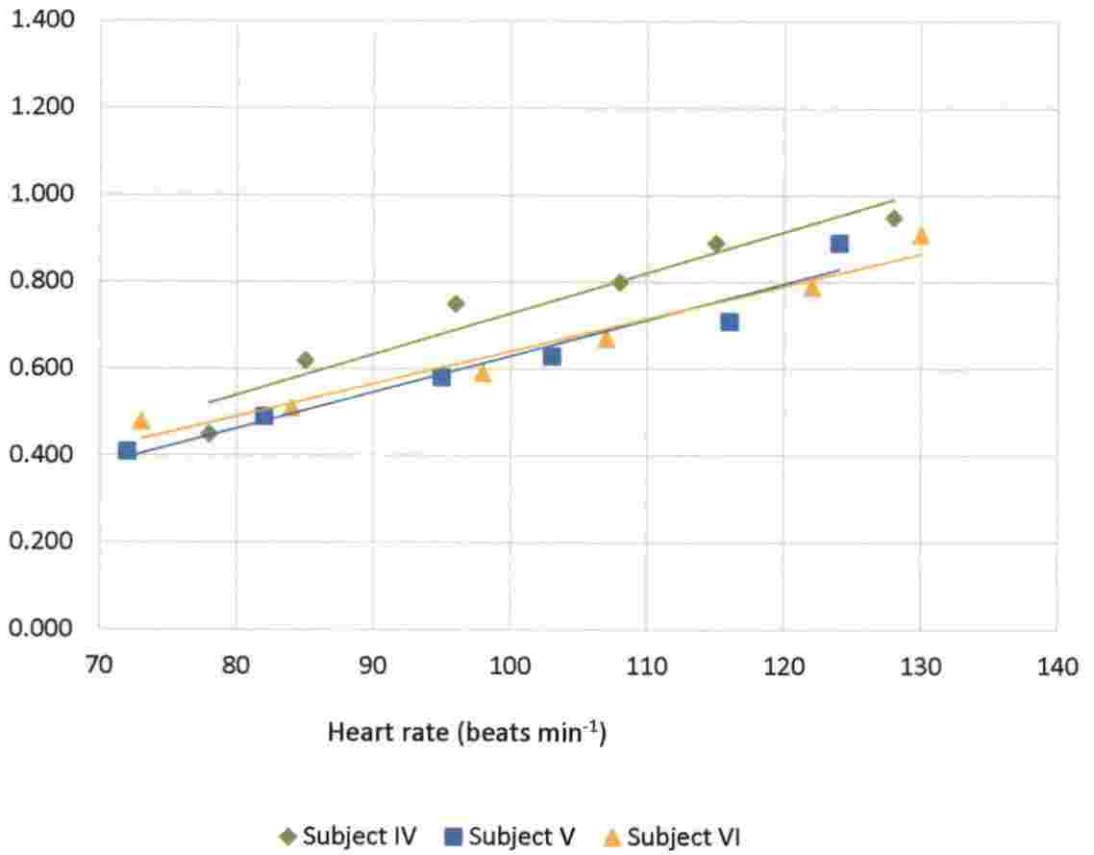

$R^2$  value obtained for all the six subjects were seems to be very high because they attained good fit between oxygen consumption and heart rate. It is also observed that the linear relationship between heart rate and oxygen consumption varies for individuals due to physiological differences.

#### 4.2.6 Maximum aerobic capacity ( $VO_2$ max)

The maximum heart rate of all the selected male and female subjects was computed using equation 3.1. The  $VO_2$  max for all the subjects were computed by following the procedure as explained in section 3.3.6 and the computed values are given in Table 4.6.

**Table 4.6  $VO_2$  max for selected subjects**

Sl. No.	Subjects	Gender	Maximum heart rate (beats $min^{-1}$ )	$O_2$ max ( $l\ min^{-1}$ )
1	I	Male	166.44	1.5978
2	II		168.30	1.4729
3	III		168.92	1.7356
4	IV	Female	179.46	1.4762
5	V		178.84	1.2800
6	VI		178.84	1.2350

The values of  $VO_2$  max of subjects are similar to the values of  $VO_2$  max reported by many authors like Nag (1981), Nag *et al.* (1988), Vidhu (2001), Sivakumar (2001), Singh *et al.* (2001) and Thambidurai (2007). Individual differences in the value of the maximum  $VO_2$  may be due to the differences in the ability to supply oxygen to the muscles, due to genetic factors or due to failure of muscle power. Bridger (1995) and Noakes (1988) were also claimed these. Varghese *et al.* (1995) reported that  $VO_2$  max is well correlated with both age and body weight.

#### 4.4 EVALUATION OF BRUSH CUTTER

Field evaluation of brush cutter was conducted with and without attaching vibration reducing aid by all the selected subjects. Heart rate and vibration

measurements were carried out as explained in section 3.3. The data of heart rate measurement is used for computing  $VO_2$  and energy expenditure of subject. The observed vibration measurement data are presented as table in Appendix II to IX.

#### 4.3.1 Energy expenditure for brush cutter operation

The heart rate data (HR) of all subjects were recorded with the Polar heart rate meter during operation of the selected brush cutters with four cutter heads. The data were downloaded to the computer and the values for individual subjects were arrived. Corresponding values of oxygen consumption rate ( $VO_2$ ) of the subjects were predicted from the calibration chart of the corresponding subjects as given in section 4.2.2 and given in Appendix I. The oxygen consumption and energy expenditure were calculated and presented in Table 4.7 and Table 4.8. The energy expenditure for cutting operation for male and female subjects for two models of brush cutter were given in Figure 4.3 and Figure 4.4

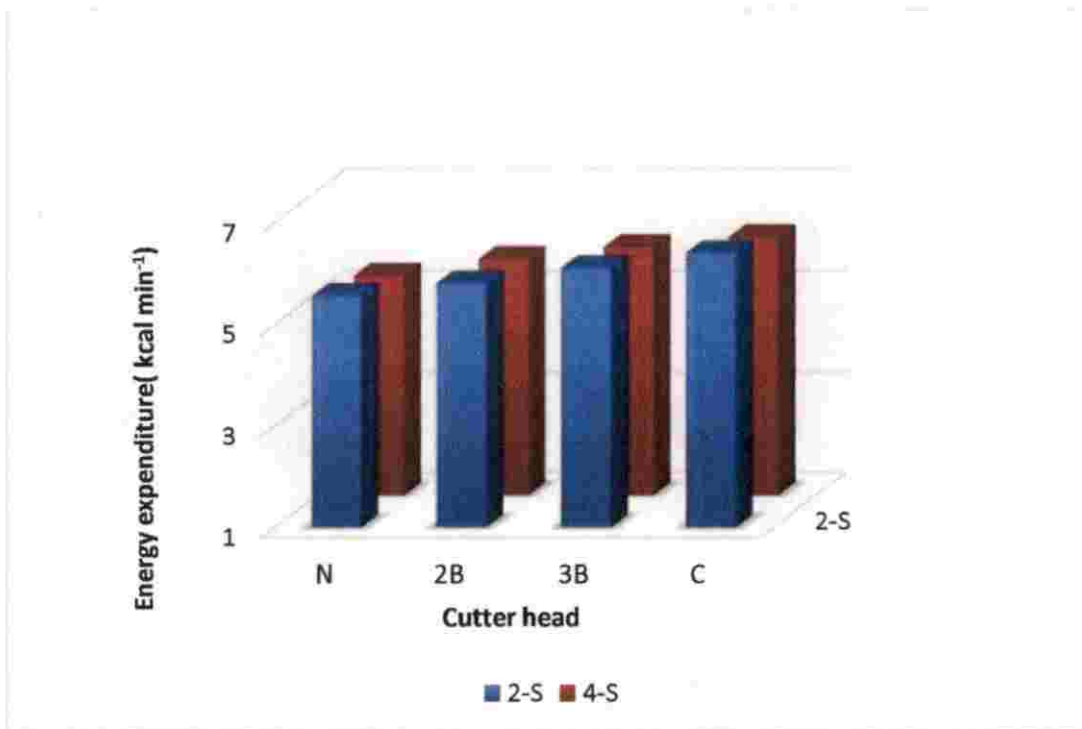

**Figure 4.3 Energy expenditure of male subjects for 2 stroke and 4 stroke brush cutter operation**

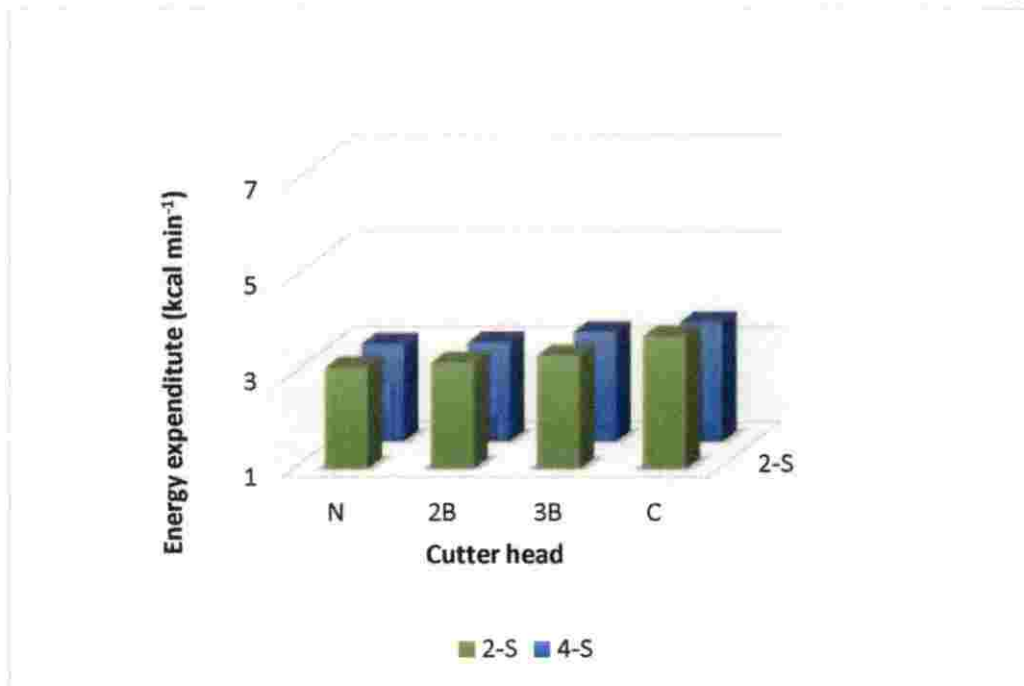

**Figure 3.4 Energy expenditure of female subjects for 2 stroke and 4 stroke brush cutter operation**

From Figure 3.3, it is revealed that there is slight increase in the energy expenditure of male subjects while operating different cutter heads in the order of nylon rope (N), 2blade cutter head (2B), 3 blade cutter head (3B) and circular saw blade(C). There is no much difference in energy expenditure between two brush cutter models. The same trend is repeated for female subjects for operating brush cutter. The energy expenditure is found to be high for male subjects compared to female. This may be due to the reason that male subjects operate brush cutter at higher speed and clear more area within specified time than female subjects.

According to Nag (1980) the heart rate (beats  $\text{min}^{-1}$ ) for the brush cutter operation of male subjects was considered as 'heavy' work, since the observed average heart rate within a range of 121-135 beats  $\text{min}^{-1}$ . The average heart rate for female subjects were within 106 to 120 beats  $\text{min}^{-1}$  and brush cutter operation is 'moderate' work for female subjects.

**Table 4.7 Heart rate, O<sub>2</sub> consumption and energy expenditure for 2-Stroke brush cutter using different cutter heads**

Subject	Gender	BMR (kcal/day)	Heart rate (beats min <sup>-1</sup> )			Oxygen consumption(l min <sup>-1</sup> )			Energy for cutting (kcal min <sup>-1</sup> )					
			N	2B	3B	C	N	2B	3B	C	N	2B	3B	C
I	Male	1612.980	108	113	120	126	1.653	1.738	1.857	1.959	6.867	7.277	7.852	8.345
II		1302.406	127	129	130	135	1.052	1.072	1.082	1.133	4.177	4.275	4.325	4.571
III		1252.314	123	127	132	135	1.358	1.405	1.463	1.498	5.691	5.916	6.199	6.369
IV	Female	971.793	110	112	108	130	0.823	0.842	0.805	1.011	3.303	3.394	3.212	4.211
V		811.499	112	115	120	123	0.726	0.751	0.792	0.817	2.944	3.064	3.264	3.385
VI		951.758	118	120	132	135	0.779	0.794	0.884	0.906	3.102	3.174	3.609	3.717

**Table 4.8 Heart rate, O<sub>2</sub> consumption and energy expenditure for 4-Stroke brush cutter using different cutter heads**

Subject	Gender	BMR (kcal/day)	Heart rate (beats min <sup>-1</sup> )			Oxygen consumption(l min <sup>-1</sup> )			Energy for cutting (kcal min <sup>-1</sup> )					
			N	2B	3B	C	N	2B	3B	C	N	2B	3B	C
I	Male	1612.980	106	111	115	119	1.619	1.704	1.772	1.840	6.702	7.113	7.441	7.770
II		1302.406	119	125	129	132	0.970	1.031	1.072	1.103	3.783	4.078	4.275	4.423
III		1252.314	120	125	128	130	1.323	1.381	1.416	1.440	5.521	5.803	5.973	6.086
IV	Female	971.793	109	113	115	119	0.814	0.852	0.870	0.908	3.258	3.439	3.530	3.712
V		811.499	115	112	120	123	0.751	0.726	0.792	0.817	3.064	2.944	3.264	3.385
VI		951.758	109	110	117	125	0.711	0.719	0.771	0.831	2.776	2.811	3.065	3.355

### 4.3.2 Hand Arm Vibration in brush cutter

Hand arm vibration measurements (HAV) of brush cutter operation is carried out at the Instructional Farm of K.C.A.E.T., Tavanur. Three male and female subjects each were operated with four stroke and two stroke models of brush cutters with all the four selected cutter heads separately (Plate 4.1). Each trial of twenty minute duration and sufficient rest period in between was used for completing the experiment. Hand arm vibrations on both left and right handles of brush cutter were measured using VB-8201HA Vibration meter.

The HAV measurements at handles of brush cutter were taken and peak values and RMS values of acceleration are noted as explained in 3.5.1. The measured HAV values at both handles of brush cutter with and without vibration reducing aid are presented in Appendix II to Appendix IX and the measured data were statistically analysed.



**Plate 4.1 Brush cutter with vibration reducing aid**

### 4.3.2 Statistical analysis

Significance of various parameters like developed vibration reducing aid, type of cutter head and stroke over the excitation of vibration at both handle was analysed using the standard programme of MSTAT for Factorial Completely

Randomised Design (FCRD) with vibration data values of the selected six subjects. The proposed method of evaluating occupational risk related to mechanical vibration exposure while working with brush cutter makes it possible to account the effect of attachment, cutter head and type of internal combustion engine.

#### 4.3.3.1 HAV at right handles of brush cutter for male subjects

Peak value and RMS value of acceleration obtained are broadly consistent with major trends in reduction in vibration excitation at both handles of brush cutter while attached with developed vibration reducing aid, compared to conventional operation of brush cutter for all subjects.

The HAV at right handles for male subjects are given in Table 4.9 to Table 4.12.

**Table 4.9 Peak maximum values of HAV at right handles of brush cutter for male subjects**

Blade	NA		Mean	A		Mean
	2S	4S		2S	4S	
N	188.700	186.700	187.700	178.767	174.300	176.533
B2	192.700	189.667	191.183	176.667	177.767	177.217
B3	196.700	194.553	195.617	187.167	181.333	184.250
C	197.933	196.367	197.150	192.367	184.767	188.567
Mean	194.008	191.817	192.913	183.742	179.542	181.642

**Table 4.10 Peak minimum values of HAV at right handles of brush cutter for male subjects**

Blade	NA		Mean	A		Mean
	2S	4S		2S	4S	
N	119.167	115.80	117.483	112.433	106.033	109.233
B2	125.633	122.633	124.133	112.267	109.100	110.683
B3	134.067	131.233	132.650	118.533	110.833	114.683
C	134.333	136.700	135.517	123.333	117.233	120.283
Mean	128.300	126.592	127.446	116.642	110.800	113.721

The statistical ANOVA table of peak values of HAV at right handles of brush cutter for male subjects were given Appendix II. The statistical analysis indicates that developed vibration reducing aid (A), type of cutter head (B) and type of internal combustion engine (S) were highly significant ( $P < 0.01$ ) with 1 per cent

level of significance in excitation of HAV in right handles. There is no significant reduction of specific combination of vibration reducing aid with cutter head, vibration reducing aid with type of internal combustion engine, cutter head with type of internal combustion engine or combination of type of vibration reducing aid with cutter head and type of internal combustion engine.

**Table 4.11 RMS maximum values of HAV at right handles of brush cutter for male subjects**

Blade	NA		Mean	A		Mean
	2S	4S		2S	4S	
N	166.967	159.033	163.00	159.300	144.467	151.883
B2	173.200	165.767	169.483	163.733	157.133	160.433
B3	177.633	170.100	173.867	169.567	161.633	165.600
C	179.300	174.667	176.983	169.000	166.200	167.600
Mean	174.275	167.392	170.833	165.400	157.358	161.379

**Table 4.12 RMS minimum values of HAV at right handles of brush cutter for male subjects**

Blade	NA		Mean	A		Mean
	2S	4S		2S	4S	
N	119.167	115.800	117.483	112.433	106.033	109.233
B2	125.633	122.633	124.133	112.267	109.100	110.683
B3	134.067	131.233	132.650	118.533	110.833	114.683
C	134.333	136.700	135.517	123.333	117.233	120.283
Mean	128.300	126.592	127.446	116.642	110.800	113.721

The statistical ANOVA table of RMS values of HAV at right handles of brush cutter for male subjects were given Appendix III. The HAV is found to be minimum for nylon rope and maximum for circular saw type head and is increasing in trend from nylon rope cutter head, 2-blade type cutter head, 3-blade type cutter head and circular saw type head. The result revealed that the vibration excitation on handles are increasing with the increase in number of cutting points. For nylon rope cutter heads since it is flexible, the vibration due to working of head would not transmitted to the hands. Also that brush cutter with 4 stroke engine has less HAV than that with 2 stroke engine though the difference is very little.

### 4.3.3.2 HAV at right handles of brush cutter for female subjects

The HAV at right handles of brush cutter for female subjects are presented in Table 4.13 to Table 4.16. The excitation of HAV are discussed based on statistical ANOVA table of Peak values and RMS values of HAV at right handles of brush cutter for female subjects which were given Appendix IV and Appendix V.

**Table 4.13 Peak maximum values of HAV at right handles of brush cutter for female subjects**

Blade	NA		Mean	A		Mean
	2S	4S		2S	4S	
N	179.667	178.200	178.933	184.833	176.733	180.783
B2	179.033	176.833	177.933	194.100	174.900	184.500
B3	190.967	161.233	176.100	190.800	162.033	176.417
C	186.367	186.367	186.367	186.367	190.267	188.317
Mean	184.008	175.658	179.833	189.025	175.983	182.504

**Table 4.14 Peak minimum values of HAV at right handles of brush cutter for female subjects**

Blade	NA		Mean	A		Mean
	2S	4S		2S	4S	
N	119.167	115.80	117.483	112.433	106.033	109.233
B2	125.633	122.633	124.133	112.267	109.100	110.683
B3	134.067	131.233	132.650	118.533	110.833	114.683
C	134.333	136.700	135.517	123.333	117.233	120.283
Mean	128.300	126.592	127.446	116.642	110.800	113.721

**Table 4.15 RMS maximum values of HAV at right handles of brush cutter for female subjects**

Blade	NA		Mean	A		Mean
	2S	4S		2S	4S	
N	164.233	157.767	161.000	157.433	153.867	155.650
B2	139.003	169.467	154.235	153.733	154.700	154.217
B3	152.000	132.900	142.450	165.367	129.0	147.183
C	158.633	155.567	157.100	150.767	140.233	145.500
Mean	153.468	153.925	153.696	156.825	144.450	150.637



**Table 4.16 RMS minimum values of HAV at right handles of brush cutter for female subjects**

Blade	NA		Mean	A		Mean
	2S	4S		2S	4S	
N	119.167	115.800	117.483	112.433	106.033	109.233
B2	125.633	122.633	124.133	112.267	109.100	110.683
B3	134.067	131.233	132.650	118.533	110.833	114.683
C	134.333	136.700	135.517	123.333	117.233	120.283
Mean	128.300	126.592	127.446	116.642	110.800	113.721

Statistical analysis showed that the HAV have no significant difference in developed vibration reducing aid (A), type of cutter head (B) and type of internal combustion engine (S) because  $P > 0.05$ , but type of internal combustion engine is significant in terms of peak maximum ( $0.05 > P > 0.01$ ) at 5 per cent level of significance.

The results obtained for vibration measurement in right handle for female subjects has not showing any significance of attachment or brush cutter models. The most likely explanation of negative result is that subjects are not using mechanical advantage of that attachment instead they are exerting more force to balance the weight of the same. This can be overcome by imparting proper training for using brush cutter with the attachments.

#### **4.3.3.3 HAV at left handles of brush cutter for male subjects**

The HAV at left handles for male subjects are given in Table 4.17 to Table 4.20. The statistical ANOVA table of Peak values of HAV at left handles of brush cutter for male subjects which were given Appendix VI.

**Table 4.17 Peak maximum values of HAV at left handles of brush cutter for male subjects**

Blade	NA		Mean	A		Mean
	2S	4S		2S	4S	
N	180.567	173.000	176.783	172.267	168.457	170.367
B2	179.733	185.567	182.650	158.333	176.900	167.617
B3	183.567	187.867	185.717	177.533	181.200	179.367
C	189.433	187.700	188.567	174.967	170.033	172.500
Mean	183.325	183.533	183.429	170.775	174.150	172.462

**Table 4.18 Peak minimum values of HAV at left handles of brush cutter for male subjects**

Blade	NA		Mean	A		Mean
	2S	4S		2S	4S	
N	123.800	123.300	123.550	117.067	139.967	128.517
B2	105.333	120.200	112.767	101.500	114.667	108.083
B3	122.067	139.567	130.817	135.567	145.733	140.650
C	112.933	137.467	125.200	107.633	124.500	116.067
Mean	116.033	130.133	123.083	115.442	131.217	123.329

The statistical analysis indicates that developed vibration reducing aid (A), type of cutter head (B) and type of internal combustion engine (S) were significant ( $P < 0.05$ ) with 5 per cent level of significance in excitation of HAV in brush cutter left handles.

**Table 4.19 RMS maximum values of HAV at left handles of brush cutter for male subjects**

Blade	NA		Mean	A		Mean
	2S	4S		2S	4S	
N	170.267	143.067	156.667	157.800	149.567	153.683
B2	142.333	150.367	146.350	145.300	147.800	146.550
B3	160.533	174.267	167.400	164.267	156.733	160.500
C	178.433	160.333	169.383	162.100	156.300	159.200
Mean	162.892	157.008	159.950	157.367	152.600	154.983

**Table 4.20 RMS minimum values of HAV at left handles of brush cutter for male subjects**

Blade	NA		Mean	A		Mean
	2S	4S		2S	4S	
N	104.400	101.167	102.783	114.567	98.867	106.717
B2	106.867	105.800	106.333	97.867	113.900	105.883
B3	118.133	120.700	119.417	113.800	115.400	114.600
C	123.533	107.933	115.733	126.100	106.533	116.317
Mean	113.233	108.900	111.067	113.083	108.675	110.879

The statistical ANOVA table of RMS values of HAV at left handles of brush cutter for male subjects which were given Appendix VII. The results obtained for vibration measurement in left handle for male subjects has not showing significance

of attachment or brush cutter models since HAV at left handles is less as compared to right handles. This may be because of the fact that, the major control of the brush cutter by the subject is using right handle and left handle is just supporting only. Moreover the weight of brush cutter is supported mainly by right shoulders and at the left is not much affected.

#### 4.3.3.4 HAV at left handles of brush cutter for female subjects

The HAV at left handles for male subjects are given in Table 4.21 to Table 4.24. The statistical ANOVA table of Peak values and RMS values of HAV at left handles of brush cutter for female subjects which were given Appendix VIII and Appendix IX.

**Table 4.21 Peak maximum values of HAV at left handles of brush cutter for female subjects**

Blade	NA		Mean	A		Mean
	2S	4S		2S	4S	
N	184.833	176.733	180.783	173.967	156.100	165.033
B2	194.100	174.900	184.500	178.100	152.467	165.283
B3	190.800	162.033	176.417	174.233	144.333	159.283
C	186.367	190.267	188.317	161.433	183.967	172.700
Mean	189.025	175.983	182.504	171.933	159.217	165.575

**Table 4.22 Peak minimum values of HAV at left handles of brush cutter for female subjects**

Blade	NA		Mean	A		Mean
	2S	4S		2S	4S	
N	121.967	88.967	105.467	117.500	72.200	94.850
B2	85.233	116.833	101.033	90.067	88.867	89.467
B3	131.600	110.267	120.933	115.933	106.733	111.333
C	121.300	119.467	120.383	117.500	115.000	116.250
Mean	115.025	108.883	111.954	110.250	95.700	102.975

**Table 4.23 RMS maximum values of HAV at left handles of brush cutter for female subjects**

Blade	NA		Mean	A		Mean
	2S	4S		2S	4S	
N	170.267	143.067	156.667	157.800	149.567	153.683
B2	142.333	150.367	146.350	145.300	147.800	146.550
B3	160.533	174.267	167.400	164.267	156.733	160.500
C	178.433	160.333	169.383	162.100	156.300	159.200
Mean	162.892	157.008	159.950	157.367	152.600	154.983

**Table 4.24 RMS minimum values of HAV at left handles of brush cutter for female subjects**

90

Blade	NA		Mean	A		Mean
	2S	4S		2S	4S	
N	114.433	100.433	107.433	103.633	76.733	90.183
B2	125.900	124.500	125.200	97.233	85.900	91.567
B3	128.267	97.300	112.783	96.833	96.800	96.817
C	99.300	131.600	115.450	89.300	107.933	98.617
Mean	116.975	113.458	115.217	96.750	91.842	94.296

Unlike at right handle, the statistical result at left handle indicate showing highly significant ( $P < 0.01$ ) reduction of hand arm vibration for female subjects while using vibration reducing aid along with brush cutter and with 1 per cent level of significance in excitation of HAV in left handles. The measured data of HAV in left handle for female subjects is less as compared to right handles.

#### 4.3.3. Subject Rating

Subjective rating of brush cutter with and without developed vibration aid were noted as explained in 3.6.2. The scores obtained for ODR, OER, OSR and BPDS are explained in this section.

##### 4.3.3.1 Overall Discomfort Rating (ODR)

The Overall discomfort scores of each of male and female subjects for operating the selected brush cutters were arrived as explained in section 3.6.2.1. The ODR for the operation of selected brush cutters with six different subjects are presented in Appendix X. The mean values of ODR of the subjects are furnished in Figure 4.5.

It was found that subjects having moderate discomfort while using different cutter heads on both machines since they have to carry it on shoulders and mechanical vibration is directly transferred to the body through hands and shoulders. The discomfort rate was found to be increasing for cutter heads in the order nylon rope, 2 blade, 3 blade and circular blade respectively for both male and female subjects. Also the discomfort rate was found to be higher in brush cutter with 2 stroke engine than that of 4 stroke engine.

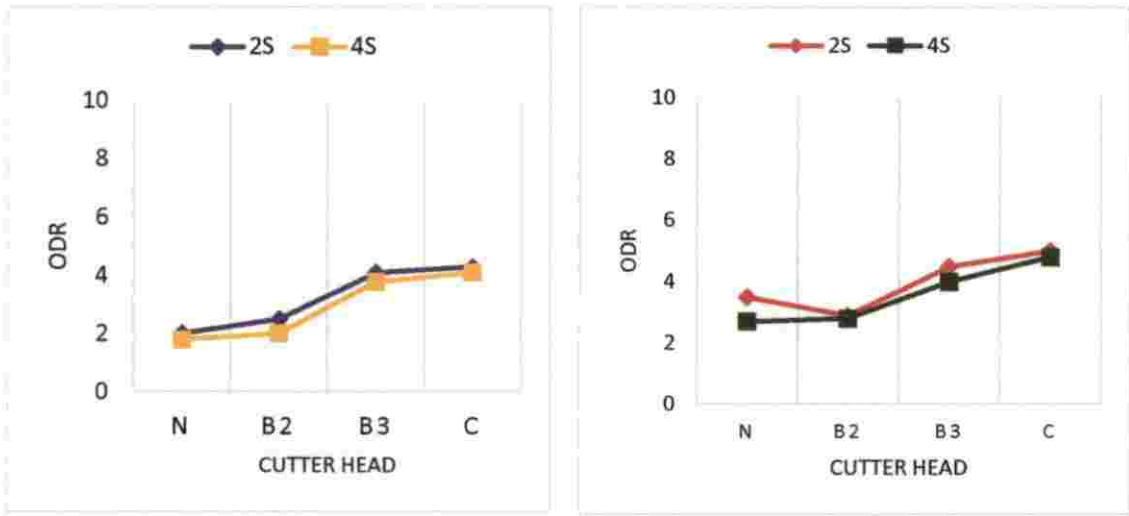

**Figure 4.5 ODR of male and female subjects while operating brush cutter**

The ODR for male and female subjects while operating brush cutter attached with developed vibration reducing aid are presented in Figure 4.6. The values are given Appendix X

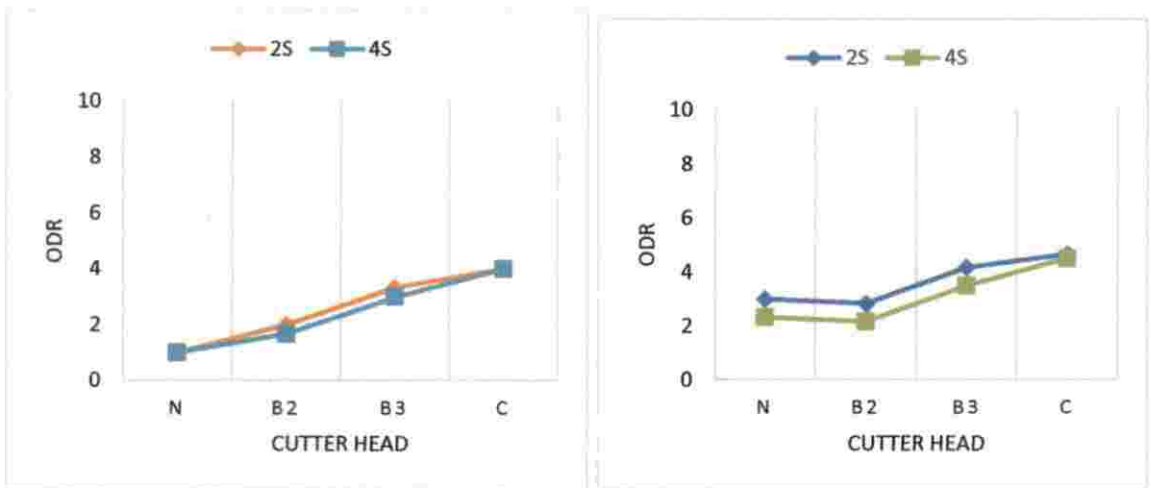

**Figure 4.6 ODR of male and female subjects while operating brush cutter with attachment**

The ODR values of male and female shows that brush cutter operation with developed vibration reducing aid lowers the discomfort for both male and female subjects. The subjects can balance brush cutter easily as attachment is supported

on the ground level. The developed vibration reducing aid is provided with rollers makes it possible to move brush cutter in any direction easily. 92

#### 4.3.3.2 Overall Safety Rating

The overall safety rating scores of each of male and female subjects for operating the selected brush cutters were arrived as explained in section 3.6.2.2. The OSR for the operation of selected brush cutters with six different subjects are presented in Appendix XI. The mean values of OSR of the subjects are furnished in Figure 4.7.

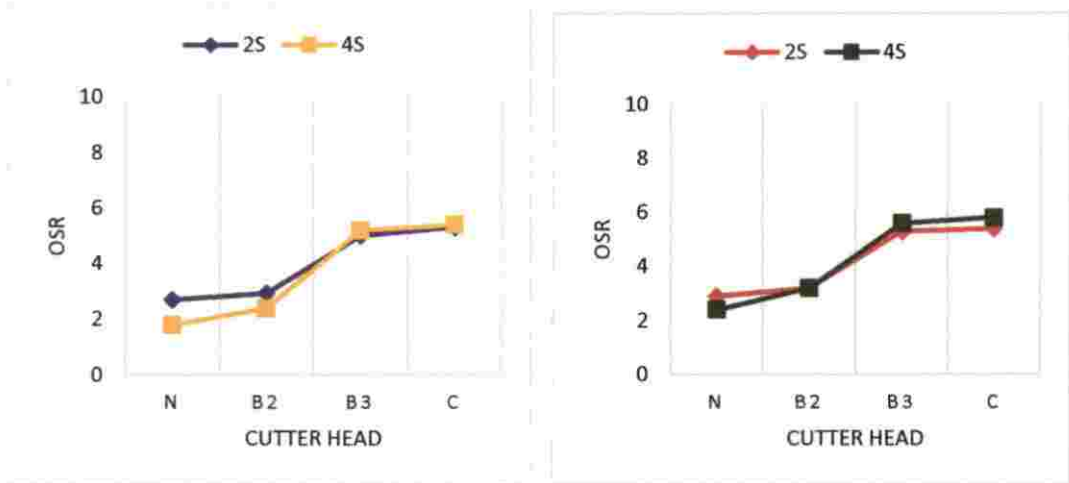

**Figure 4.7 OSR of male and female subjects while operating brush cutter**

The OSR for brush cutter is similar for brush cutters with 4 stroke and 2 stroke engines. OSR is varying from the range of 'secure and meager fear' to 'moderately secure and less fear' for male subjects and 'secure and meager fear' to 'slightly secure and moderate fear' for female subjects. This implies that female workers give more cautious in operating machine whereas male workers takes it as lighter as possible. Also brush cutter using nylon rope for cutters give more safe feeling for both category of subjects.

The OSR is noted for subjects while operating brush cutter with developed vibration reducing aid. OSR is noted as explained in section 3.6.2.2. The OSR for male and female subjects are presented in Figure 4.8. The values are given Appendix XII. 93

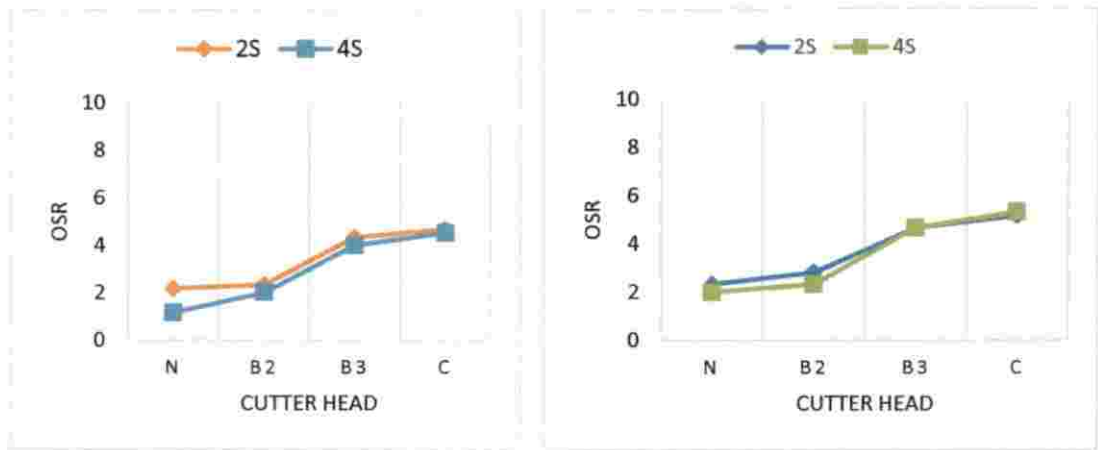

**Figure 4.8 OSR of male and female subjects while operating brush cutter with attachment**

The OSR values of male and female shows that brush cutter operation with developed vibration reducing aid increase the safety for both male and female subjects. The developed vibration aid is symmetric with respect to the brush cutter shaft which uniformly distribute the weight to ground and subjects don't need to bear the whole weight of brush cutter. Subjects having more safety feeling compared to brush cutter not attached to vibration reducing aid.

#### 4.3.3.3 Overall Ease of operation rating (OER)

The Overall Ease of operation rating scores of male and female subjects for brush cutter operation were arrived as explained in section 3.6.2.3. The OER for the operation of selected brush cutters with six different subjects are presented in Appendix XII. The mean values of OER of the male and female subjects are presented in Figure 4.9.

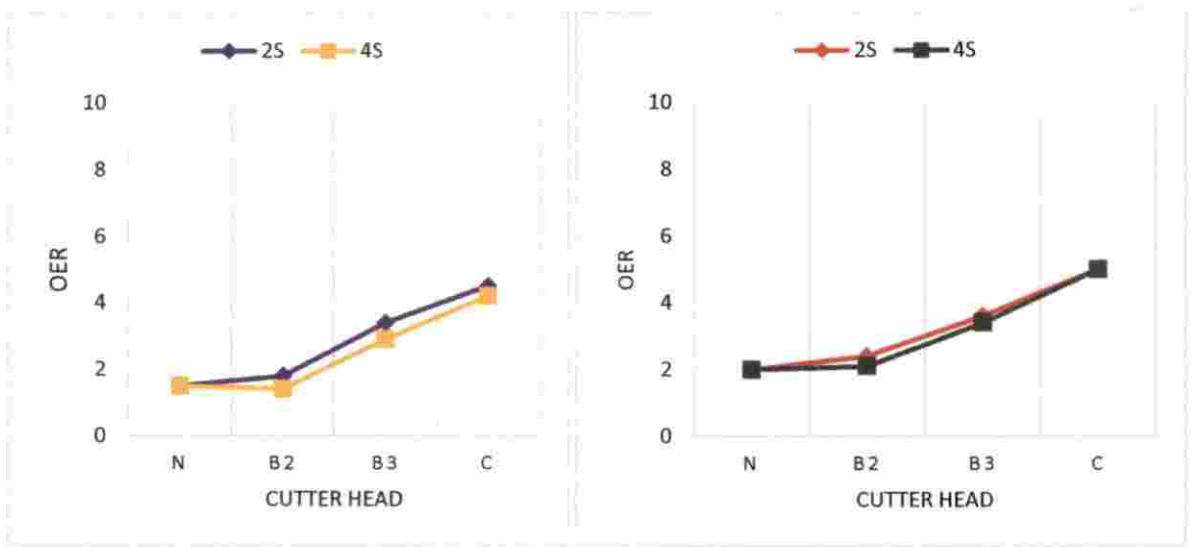

Figure 4.9. OER of male and female subjects while operating in brush cutters

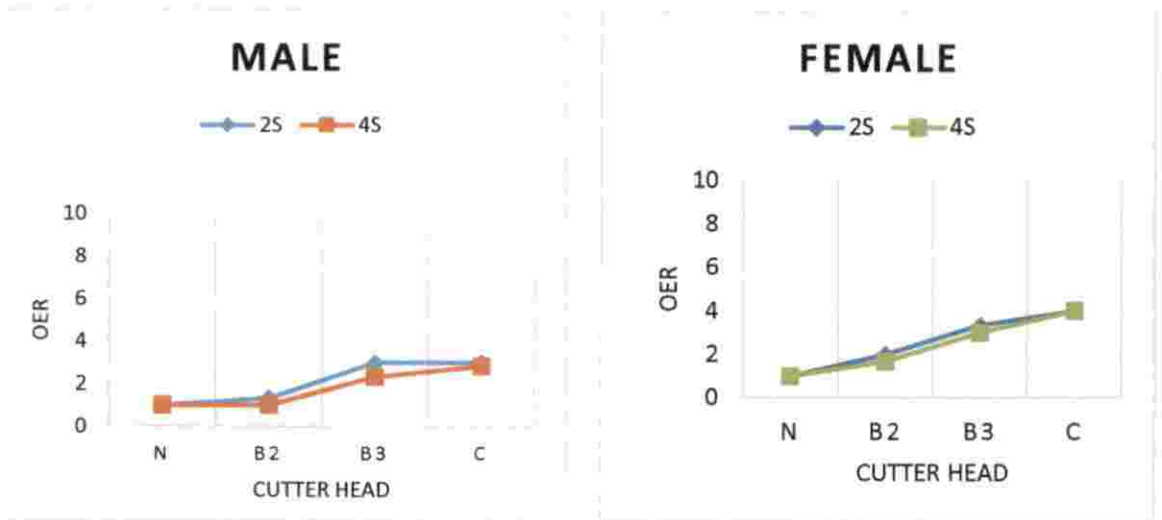

Figure 4.10. OER of male subjects while operating in brush cutters with attachment

Brush cutter with 4 stroke engine and 2 stroke engine has not shown much difference in ease of operation for both subjects. But it is clear that the ease of operation varying for different cutter heads. It varies in the order of nylon rope, 2 blade, 3 blade and circular blade. Cutter heads with 3 blade and circular blade shows slight difficulty for both subjects. This may be because of the increase in cutting points and increase in contact area for 3 blade and circular blade compared to others. As the number of cutting points increased the force transmitted to the

94



body has also increasing in unit time. The increase in contact area also increases friction and thereby increase in force transmitted

The OER values are noted as explained in section 3.6.2.3. The OER values for male and female subjects were given in Figure 4.10. From the values obtained for OER, there is increase in ease of operation compared to brush cutter without attaching to vibration reducing aid. The developed vibration aid sustains a part of weight of machine and the roller provided makes it possible move easily while operating.

#### 4.3.3.4 Body Part Discomfort Score (BPDS)

Based on the Corlett and Bishop (1976) regional discomfort scale, body part discomfort score for subjects for operating the selected brush cutters were arrived as explained in the section 3.6.2.4. The Body Part Discomfort Score (BPDS) values assessed for all the selected brush cutters with different cutter heads are presented in Appendix XIII and the mean values of Body Part Discomfort Score (BPDS) of the male and female subjects are furnished in Table 4.25 and 4.26.

**Table 4.25 BPDS of male subjects for different brush cutter operation**

Sl. No.	Brush cutter	BPDS	Body part experiencing pain
1	2 stroke	42.33	Moderate pain in shoulders, neck, right thigh, right wrist and right palm
2	4 stroke	38.67	

**Table 4.26 BPDS of female subjects for different brush cutter operation**

Sl. No.	Brush cutter	BPDS	Body part experiencing pain
1	2 stroke	47.33	Moderate pain in shoulders, neck, right thigh, right wrist and right palm
2	4 stroke	44.00	

The mean BPDS value while operating brush cutter with 2 stroke was found 42.33 and 47.33 for male and female subjects respectively. The subject has to carry whole brush cutter with cutter head in one shoulder and engine is held near to the right thigh. For operating brush cutter with 4 stroke engine the mean BPDS values were 38.67 and 44.00 which is less than that of 2 stroke engine. The mechanical

vibration is directly transferred to the body of subjects through both hands and shoulders. The subject has to stand for longer duration and both hands should be held tightly to the handles of brush cutter during brush cutter operation.

The same procedure as in section 4.3 is followed for operating brush cutter with developed vibration reducing aid. The body part discomfort rating of male and female subjects while operating brush cutter attached with developed vibration aid are noted as presented in Table 4.27. and Table 4.28.

**Table 4.27 BPDS of male subjects for operating brush cutter with attachment**

Sl. No.	Brush cutter	BPDS	Body part experiencing pain
1	2 stroke	37.33	Light discomfort in shoulders, neck, right thigh, right wrist and right palm
2	4 stroke	32.33	

**Table 4.28 BPDS of female subjects for operating brush cutter with attachment**

Sl. No.	Brush cutter	BPDS	Body part experiencing pain
1	2 stroke	43.33	Light discomfort in shoulders, neck, right thigh, right wrist and right palm
2	4 stroke	38.33	

From the results shown in Table 4.27 is revealed that the BPDS for male subjects working with brush cutter with 2 stroke and 4 stroke engines are reduced when attached to vibration reducing aid. Similar results were shown by female subjects presented in Table 4.28 while brush cutter operating with vibration reducing aid. This might be due to the transfer of vibration produced at cutter head to the ground through ground contact points of vibration reducing aid. Also may be due to the decrease in weight of machine subject have to carry in brush cutter operation.

*Summary and  
Conclusion*

## CHAPTER V

### SUMMARY AND CONCLUSION

98

The petrol-engine driven grass trimmers are widely used in Kerala for clearing lands and general agricultural work. The workers involved in these activities are generally contract workers with no or little awareness of the effect of vibration on their health. Brush cutter is sustained by human operator on his shoulders and in the same time on his right feet. Operator controls it with the hands with bended forward while standing. These workers are exposed to HAV during the work of grass cutting. Hand-arm vibration syndrome is disorder resulting from prolonged exposure to vibration, specifically to the hands and forearms while using vibrating tools. Symptoms include numbness, tingling, and loss of nerve sensitivity

Thus necessary ergonomic refinements were made for enhanced comfort of the operator without jeopardizing the efficiency of the brush cutter. The conventional brush cutter has disadvantage of vibration above permissible levels, thus resulted in development of a vibration reducing aid.

Thirty two different anthropometric dimensions pertinent to the brush cutter operation and hand arm vibration which were useful for the design of vibration reducing aid was identified, for the study were recorded by following standard anthropometric procedure. Six subjects (three each for men and women) were selected, who having anthropometric dimensions conforming to statistical requirements and screened for normal health by medical investigations. All the subjects were calibrated in the laboratory to determine the relationship between heart rate and oxygen uptake. The oxygen consumption of the subjects was measured with the Benedict- Roth Recording Spirometer and the heart rate using Polar RS300X heart rate monitor.

The ergonomic aspects and hand transmitted vibrations of brush cutters were studied by operating in K.C.A.E.T.,Tavanur. The suitable vibration reduction aid for brush cutters is designed and developed in College of Horticulture, Vellanikara.

The evaluation of the brush cutter and vibration reduction aid in field were done in the instructional farm at K.C.A.E.T., Tavanur.

Two types commonly used brush cutters (4 stroke engine and 2 stroke engine) were selected for the study. They are Honda-GX31 (4 stroke, single cylinder) and Redlands-RBC 252 (2stroke, single cylinder). Four different cutter heads used for clearing grass and brush woods viz. Nylon rope, 2-blade type, 3-blade type and circular blades were selected for the study. Experimental data were collected in three replications for both male and female subjects for each type of cutter head and type of brush cutter. The brush cutter is operated at same speed and the subjects were worn safety measures like gloves, shoes, belt, and goggles. The subject was given all the relevant instructions prior to the measurements. Ninety six trials were conducted. In each trail subject was given a rest period of 5 minutes after operating brush cutter for 25 minutes in real working condition. After every trial subject is instructed to mark the perceived exertion in the scale.

- i. It is observed that the oxygen consumption and BMR is higher for male subjects compared to female subjects. Highest value for O<sub>2</sub> consumption and BMR obtained is for subject I (1.3906 l and 1612.980 kcal/day). Also the minimum value for female obtained for subject V is oxygen consumption of 0.6997 l and BMR of 811.499 kcal/day.
- ii. The selected six subjects were calibrated in the laboratory by indirect assessment of oxygen uptake. A calibration chart was prepared with heart rate as the ordinate and the oxygen uptake as the abscissa for the selected six subjects. The relationship between the heart rate and oxygen consumption of the subjects was found to be linear for all the subjects.
- iii. The mean heart rate, and oxygen consumption were averaged for getting mean value for operating of each cutter head in 2 stroke and 4 stroke model brush cutters.
- iv. According to Nag (1980) the brush cutter operation for male subjects considerate as 'heavy' work since average heart rate within range of 121-135 beats min<sup>-1</sup>.

- v. The average heart rate for female subjects are within 106 to 120 beats  $\text{min}^{-1}$ , and brush cutter operation is 'moderate' work for female subject.
- vi. The energy expenditure for operating brush cutter is calculated for all subjects.
- vii. There is no much difference in energy expenditure between two brush cutter models for both male and female operators.
- viii. The hand arm vibration at the handles of the brush cutter were measured by using VB-8201HA vibration meter. The accelerometer is attached to the handles of the brush cutters and measurements were taken for two brush cutters without and with vibration reducing aid.
- ix. The location and orientation of VB-8201HA vibration meter followed as per ISO-22867
- x. From the statistical analysis it is found that developed vibration reducing aid, type of cutter head and type of internal combustion engine has significance in vibration excitation in both right and left handles of brush cutter.
- xi. Vibration excitation at handles are increasing in the order of using nylon rope cutter head, 2 blade type cutter head, 3 blade type cutter head and circular saw type cutter.
- xii. The observation shows that brush cutter 4 stroke engine has less hand arm vibration as compared to brush cutter with 2 stroke engine.
- xiii. It was found that subjects having moderate discomfort while using different cutter heads on both machines since they have to carry it on shoulders and mechanical vibration is directly transferred to the body through hands and shoulders.
- xiv. OSR is varying from the range of 'secure and meager fear' to 'moderately secure and less fear' for male subjects and 'secure and meager fear' to 'slightly secure and moderate fear' for female subjects.
- xv. Female workers give more cautiousness in operating machine whereas male workers take it as lighter as possible.
- xvi. Brush cutter with 4 stroke engine and 2 stroke engine has not shown much difference in ease of operation for both subjects.

- xvii. The ease of operation varying for different cutter heads in the order of nylon rope, 2 blade, 3 blade and circular blade.
- xviii. The subject has to carry whole brush cutter with cutter head in one shoulder and engine is held near to the right thigh invites some difficulty for the operators.
- xix. The mechanical vibration is directly transferred to the body of subjects through both hands and shoulders. The subject has to stand for longer duration and both hands should be held tightly to the handles of brush cutter during brush cutter operation.

## *References*



## REFERENCES

103

- [Anonymous1]. 2015. A-Z of Tree terms:A companion of British Arboriculture[online]. Available:<http://www.treeterms.co.uk/definitions/brush-cutter>. [31Oct.2015]
- [Anonymous2]. 2016. Medicinenet.com [online]. Available: <http://www.medicinenet.com/script/main/art.asp?articlekey=19713> [31march.2016]
- Astrand, I. 1960. Aerobic work capacity in men and women. *Acta Physiologica Scandinavica*. 4, Supplement 169.
- Astrand, P. O. and Rodahl, K. 1977. Textbook of work physiology. McGraw Hill, New York
- Azmir, N. A., Ghazali, M. and Yahya, M. 2014. Hand Arm Vibration and Personal Noise exposure Characteristics of a Hand held Grass Cutter machines. The 21st international congress on Sound and Vibration, Beijing, China.1-8.
- Borg, G. 1970. Perceived exertion as an indicator of somatic stress. *Scandinavian j. Rehabilitation Med.* 2(2):92-98.
- Brockway, J.W. 1978. Escape from the chamber, alternate method for large animal calorimetry. *Proc. Nut. Soc.*, 31(1):13-18
- Bridger, R.S. 1995. Introduction to Ergonomics. McGraw Hill Inc., St. Louis.
- Carregaro, R. L., Toledo, A. N., Christofolletti, G., Oliveira, A.B., Cardose, J. R. and Padula, R.S. 2013. Association between work engagement and perceived exertion among health care workers. *Fisioter. Mov.* 26(3):579-585.
- Chauhan, D. and Dayal, R. 2012. Postural analysis of farm women performing harvesting operation. *Prog. Agric.* 12(2):402-406.
- Corlett, E. N. and Bishop, R. P. 1976. A technique for assessing postural discomfort. *Ergonomics*, 19:175-182.

- Corlett, E. N. and Richardson, J. 1981. Pain, Posture and performance in work design and Productivity. London:27-42.
- Cvetanovic, B. and Zlatkovic, D. 2013. Evaluation of whole-body vibration risk in agricultural tractor drivers. *Bulgarian J. Agric. Sci.* 19(5):1155-1160.
- Directive 2002/44/EC of the European Parliament and of the Council of 25 June 2002 on the minimum health and safety requirements regarding the exposure of workers to the risks arising from physical agents (vibration) (sixteenth individual Directive within the meaning of Article 16 (1) of Directive 89/391/EEC).
- Dixit, J. and Namgial, D. 2012. Anthropometry of farm workers of Kashmir region of India for equipment design. *J. Agric. Engg.* 49(2):8-15.
- Durnin, J. C. G. A. 1978. Indirect calorimetry in Man. A critique on practical problems. *Proc. Nut. Soc.*, 37(1):5-11
- Eminoglu, M.B., Ozguven, M. M., Beyaz, A., Ozyurik, R., and Acar, A. I. 2010. Determining postural discomfort at working with power tiller.
- EN ISO 22867. 2006. Forestry machinery - Vibration test code for portable hand-held machines with internal combustion engine - Vibration at the handles (ISO 22867:2004).
- Fereydooni, M., Lorestani, A. N., Rabbani, N. and Javadikia, P. 2012. Measurement and Analysis of Vibration of Operator in Universal 650, Massey Ferguson 285 & MF 299 Tractors. *Int. J. Mech. Appl.* 2(5):88-92.
- Gite, L. P. and Singh, G. 1997. Ergonomics in agriculture and allied activities in India. Technical Bulletin No. CIAE/97/70, Bhopal, India.
- Gite, L. P. and Chatterjee, D. 1999. All India anthropometric survey of agricultural workers: proposed action plan. All India Coordinated Research project on Human Engineering and Safety in Agricultural Engineering, India.

- Griffin, M. J. 1990. Handbook of Human Vibration London: Academic Press. 485-530
- Gupta, P. K., Sharma, A. P. and Gupta, M. L. 1983. Anthropometric survey of Indian farm workers. *Agric. Mechanization in Asia, Afri. Latin Am.* 16(1):27-30.
- Hedge, A. 2004. Effects of electric height adjustable work surface on self-assessed discomfort and productivity in workers, Cornell University Human Factors and Ergonomics Research Laboratory. 1-31
- IS/ISO 2631-1. 1997. Mechanical Vibration and Shock - Evaluation of Human Exposure to Whole-Body Vibration - Part 1: General requirements.
- IS/ISO 5349-1. 2001. Mechanical Vibration-measurement and evaluation of human exposure to hand transmitted vibration. Part 1. General requirements.
- Joshi, S. and Veerkumar, V. 2013. Research and Development in Indian Agricultural Technology: With Special Reference to Women. *Res. J. Family, Community and Consumer Sci.* 1(9):7-16.
- Karunanithi, R. and Tajuddin, A. 2003. Physiological Response of Agricultural Workers in Rice farming Operations. *J. Agrl. Engg.* Vol 40(1):30-40.
- Kroemer, K. H. E., Kroemer, H. J. and Kroemer, K. E. 1997. Engineering Physiology. New York. Van Nostrand Reinhold.
- Laszlo, H. E. 2010. The vibration exposure of small Horticultural tools and its reduction. Budapest: convirus university of Budapest.
- Lusted, M., Healey, S. and Mandryk, J.A. 1994. Evaluation of the seating of Qantas flight deck crew. *Applied Ergonomics*, 25:275-282.
- Mallick, Z. 2008. Evaluation and optimisation of handle design parameters of a Grass trimming machine. *Int. J. Occupational Safety and Economics (JOSE)*, 14(3):343-349.

- Marul, M. and Karabulut, A. 2012. Vibration effects examination of cushions used on tractor driving seat. *J. Theor. Appli. Mech.* 42(4):31-40.
- Mehta, C. R., Tiwari, P. S., and Varshney, A. C. 1997. Ride vibrations on a 7.5kw Rotary Power Tiller. *J. Agric. Engg. Res.* 66:69-176.
- Meyer, R. H. and Radwin, R. G. 2007. Comparison of stoop posture Versus Prone postures for a simulated agricultural harvesting task, *Applied Ergonomics* 38:549-555
- Mohanty, S. K., Behera, B. K., and Satapathy, G. C. 2008. Ergonomics of Farm Women in Manual Paddy Threshing. *Int. Agric. Engg.* 10:1-14.
- Monarca, D., Biondi, P., Cecchini, M., Santi, M., Guerrieri, M., Colantoni, A. and Colopardi, F. 2008. Transmission of vibrations from portable agricultural machinery to the Hand-Arm System (HAV): risk assessment and definition of exposure time for daily action and exposure limits. In: International Conference on 'Innovation Technology to Empower Safety, Health and Welfare in Agriculture and Agro-food Systems', :15-17 [On-line]. Available:[http://dspace.unitus.it/bitstream/2067/1811/1/Ragusa%202008\\_2.pdf](http://dspace.unitus.it/bitstream/2067/1811/1/Ragusa%202008_2.pdf) [30 Feb.2016]
- Nag, P. K. 1981. Predicting maximal oxygen uptake of workers engaged in agricultural tasks. *J. Hum. Ergology.*28(3),158-64.
- Nag, P. K., Goswami, A., Ashtekiar, S. P. and Pradhan, C. K. 1988. Ergonomics in sickle operation. *Applied Ergonomics.* 19: 233-239.
- Okunribido, O. O., Shimbles, S. J., Magnusson, M. and Pope, M. 2007. City bus driving and low back pain: A study of the exposures to posture demands, manual materials handling and whole-body vibration. *Applied Ergonomics.* 38:29-38.
- Petrovic, P., Bracanovic, Z. and Vukas, S. 2005. Oscillatory appearance on agricultural of tractors. *Agric. Engg.* 30(2):15-23

- Rathod, S. R. 2013. Performance and ergonomic evaluation of direct paddy seeder and mechanical rice transplanter in wet lands. M.Tech. (Agrl. Engg.) thesis. Kerala Agricultural University, Thrissur.
- Reddy, K., Baby, N., Harini, L., and Srinivas, J. 2010. Design and analysis of a revised grass trimming machine. *J. Sci. Ind. Res.*, 69, 39-42.
- Rodahl, K. 1989. The physiology of work. Taylor and Francis, London: 51-79.
- Saha, P. N. Datta, S.R., Banerjee, P. K. and Narayane, G. G. 1979. An acceptable workload for Indian workers. *Ergonomics*, 22:1069-1071.
- Sam, B., Kathirvel, K., Manian, R. and Kumar, S.T. 2007. Energy cost of riding and walking type tillers. *Agric. Mechanisation in Asia, Afri. latin Am.*38(1):55-60.
- Sanders, M. S. and McCormick, E. J. 1992. Human factors in engineering and design, McGraw-Hill International edition. McGraw-Hill Incorporation, Singapore.
- Singh, N. A., Clements, K. M. and Singh, M. A. F. 2001. The efficiency of exercise as a long-term antidepressant in elderly subjects: A randomized controlled trial. *Journal of Gerontology Series A: Medical science*. 56: 97-504.
- Singh, A., Gautam, U.S., Pannase, S. and Singh, A. 2010. Ergonomic Evaluation of Farm Women during Maize Shelling. *Indian Res. J. Ext. Edu.*10 (3):41-44.
- Sivakumar, S.S. 2001. Investigation on the performance evaluation of drum seeder as influenced by machine, ergonomic and crop parameters. PhD Thesis. Department of Farm Machinery, Tamil Nadu Agricultural University, Coimbatore, India.
- Solecki, L. 2012. Studies of farmers' annual exposure to whole body vibration on selected family farms of mixed production profile. *Ann. Agric. Environ. Med.* 19(2):247-253.
- Scarlett, A., Price, J. S. and Stayner, M. 2007. Whole-Body Vibration: Evaluation of Emission and Exposure Levels Arising from Agricultural Tractors. Silsoe Research Institute.

- Teschke, K., Nicol, A. M., Davies, H., and Ju, S. 1999. Whole Body Vibration and Back Disorders among Motor Vehicle Drivers and Heavy Equipment Operators-A Review of the Scientific Evidence. Workers compensation board of british Columbia. 1-35.
- Tewari, V.K. 2004. Integrated composite anthropometer. Indian Patent No.205834.
- Tewari, V. K., Dewangan, K. N., and Karmakar, S. 2004. Operators fatigue in field operation of hand tractors. *Biosystems Engg.* 89(1):1-11.
- Thambidurai, R. 2007. Ergonomic evaluation of weeders. Unpublished Ph.D. (Ag.) Thesis, Department of Farm Machinery, Tamil Nadu Agricultural University, Coimbatore, India.
- Tint, P., Tarmas, G., Koppel, T., Reinhold, K. and Kalle, S. 2012. Vibration and noise caused by lawn maintenance machines in association with risk to health. *Agronomy Res. Biosystem engg.* 1: 251-260.
- Tiwari, P. S., Mehta, C. R., and Varshney, A. C. 2005. Metabolic cost and subjective assessment during operation of a rotary tiller with and without an operator's seat. *Int. J. Ind. Ergonomics.* 35:361-369.
- Truta, A., Cristea, F. and Aghir, M. 2013. The influence of brush cutter's vibrations on human body. *Advanced Engg. Forum*, 8-9, 445-452.
- Uemura, M., Yoshida, J., Miyakawa, S., Oono, T. and Ishikawa, D. 2014. Vibration reduction of brush cutter considering human response characteristic. 43<sup>rd</sup> int. congress on Noise control Engg.pp.1-9. Melbourne, Australia.
- Vahab, H. B. 2015. Evaluation of physiological cost and subjective assessment of existing coconut climbing devices. M. Tech. (Agrl. Engg.) thesis. Kerala Agricultural University, Thrissur.

Vidhu, K. P. 2001. An investigation on ergonomic evaluation of selected rice farming equipment. Unpublished M. E. (Ag.) Thesis, Department of Farm Machinery, Tamil Nadu Agricultural University, Coimbatore, India. 109

Yadav, R., Pund, S., Patel, N. C., and Patel, N. C. 2010. Analytical study of strength parameters of Indian farm workers and its implication in equipment design. *Agric. Eng. Int.*: 12(2).

Yoshida, J., Uemura, M., Miyakawa, S., Oono, T., and Ishikawa, D. 2013. Reduction of High Frequency Vibration of Brush Cutter by structure Optimisation. Proc. of the World Congress on Engg. 3. London.

# Appendix



## APPENDIX I

## i. Energy expenditure of selected male subjects while operating brush cutters

Subject	BMR (kcal/day)	Heart rate (beats min <sup>-1</sup> )			Oxygen consumption(l min <sup>-1</sup> )			Energy in operation (kcal/day)					
		N	2B	3B	C	N	2B	3B	C	N	2B	3B	C
I	1612.980	108	113	120	126	1.653	1.738	1.857	1.959	11501.010	12092.447	12920.459	13630.183
II	1302.406	127	129	130	135	1.052	1.072	1.082	1.133	7317.813	7459.758	7530.730	7885.592
III	1252.314	123	127	132	135	1.358	1.405	1.463	1.498	9446.985	9772.623	10179.671	10423.900
IV	971.793	110	112	108	130	0.823	0.842	0.805	1.011	5728.587	5859.399	5597.775	7036.706
V	811.499	112	115	120	123	0.726	0.751	0.792	0.817	5050.870	5224.126	5512.887	5686.143
VI	951.758	118	120	132	135	0.779	0.794	0.884	0.906	5418.257	5522.628	6148.855	6305.412

Subject	BMR (kcal/day)	Energy for cutting (kcal/day)			Energy for cutting (kcal/min)				
		N	2B	3B	C	N	2B	3B	C
I	1612.980	9888.030	10479.467	11307.478	12017.202	6.867	7.277	7.852	8.345
II	1302.406	6015.406	6157.351	6228.323	6583.186	4.177	4.275	4.325	4.571
III	1252.314	8194.671	8520.309	8927.357	9171.585	5.691	5.916	6.199	6.369
IV	971.793	4756.794	4887.606	4625.982	6064.913	3.303	3.394	3.212	4.211
V	811.499	4239.371	4412.627	4701.387	4874.643	2.944	3.064	3.264	3.385
VI	951.758	4466.498	4570.870	5197.097	5353.654	3.102	3.174	3.609	3.717

ii. Energy expenditure of selected female subjects while operating brush cutters

Subject	BMR (kcal/day)	Heart rate (beats min <sup>-1</sup> )			Oxygen consumption(l min <sup>-1</sup> )			Energy in operation (kcal/day)					
		N	2B	3B	C	N	2B	3B	N	2B	3B	C	
I	1612.980	106	111	115	119	1.619	1.704	1.772	1.840	11264.436	11855.873	12329.022	12802.171
II	1302.406	119	125	129	132	0.970	1.031	1.072	1.103	6750.033	7175.868	7459.758	7672.675
III	1252.314	120	125	128	130	1.323	1.381	1.416	1.440	9202.757	9609.804	9854.033	10016.852
IV	971.793	109	113	115	119	0.814	0.852	0.870	0.908	5663.181	5924.805	6055.617	6317.241
V	811.499	115	112	120	123	0.751	0.726	0.792	0.817	5224.126	5050.870	5512.887	5686.143
VI	951.758	109	110	117	125	0.711	0.719	0.771	0.831	4948.586	5000.772	5366.071	5783.556

Subject	BMR (kcal/day)	Energy for cutting (kcal/day)			Energy for cutting (kcal/min)				
		N	2B	3B	C	N	2B	3B	C
I	1612.980	9651.455	10242.892	10716.041	11189.191	6.702	7.113	7.441	7.770
II	1302.406	5447.627	5873.461	6157.351	6370.268	3.783	4.078	4.275	4.423
III	1252.314	7950.442	8357.490	8601.718	8764.537	5.521	5.803	5.973	6.086
IV	971.793	4691.388	4953.012	5083.824	5345.447	3.258	3.439	3.530	3.712
V	811.499	4412.627	4239.371	4701.387	4874.643	3.064	2.944	3.264	3.385
VI	951.758	3996.828	4049.014	4414.313	4831.798	2.776	2.811	3.065	3.355

iii. Energy expenditure of cutting operation for 2 stroke and 4 stroke brush cutter

Subject code	Gender	2 STROKE			4 STROKE				
		N	2B	3B	C	N	2B	3B	C
I	MALE	6.867	7.277	7.852	8.345	6.702	7.113	7.442	7.770
II		4.177	4.276	4.325	4.572	3.783	4.079	4.276	4.424
III		5.691	5.917	6.200	6.369	5.521	5.804	5.973	6.086
Mean		5.578	5.823	6.126	6.429	5.336	5.665	5.897	6.094
IV	FEMALE	3.303	3.394	3.212	4.212	3.258	3.440	3.530	3.712
V		2.944	3.064	3.265	3.385	3.064	2.944	3.265	3.385

112

## APPENDIX II

ANOVA Table of peak values of HAV for male subjects at right handle

ANOVA Table of peak maximum values for male subjects					
Source	Degrees of freedom	Mean square	F value	Probability (%)	Significance
Factor A	1	1524.380	51.1573	0.0000	**
Factor B	3	297.218	9.9744	0.0001	**
Factor S	1	122.560	4.1130	0.0409	*
Factor A × B	3	14.510	0.4870		NS
Factor A × S	1	12.100	0.4061		NS
Factor B × S	3	7.542	0.2531		NS
Factor A × B × S	3	14.220	0.4772		NS
ANOVA Table of peak minimum values for male subjects					
Source	Degrees of freedom	Mean square	F value	Probability (%)	Significance
Factor A	1	2260.508	32.0054	0.0000	**
Factor B	3	501.287	7.0975	0.0009	**
Factor S	1	171.007	2.4212	0.1295	NS
Factor A × B	3	50.318	0.7124		NS
Factor A × S	1	51.253	0.7257		NS
Factor B × S	3	7.574	0.1072		NS
Factor A × B × S	3	9.065	0.1283		NS

\*\* -Highly significant, \* -Significant, NS -Not significant

## APPENDIX III

ANOVA Table of RMS values of HAV for male subjects at right handle

ANOVA Table of RMS maximum values for male subjects					
Source	Degrees of freedom	Mean square	F value	Probability (%)	Significance
Factor A	1	1072.575	4.2361	0.0478	*
Factor B	3	511.231	2.0191	0.1310	NS
Factor S	1	668.267	2.6393	0.1141	NS
Factor A × B	3	4.342	0.0172		NS
Factor A × S	1	4.025	0.0159		NS
Factor B × S	3	29.676	0.1172		NS
Factor A × B × C	3	11.615	0.0459		NS
ANOVA Table of RMS minimum values for male subjects					
Source	Degrees of freedom	Mean square	F value	Probability (%)	Significance
Factor A	1	2260.508	32.0054	0.0000	**
Factor B	3	501.287	7.0975	0.0009	**
Factor S	1	171.007	2.4212	0.1295	NS
Factor A × B	3	50.318	0.7124		NS
Factor A × S	1	51.253	0.7257		NS
Factor B × S	3	7.574	0.1072		NS
Factor A × B × S	3	9.065	0.1283		NS

\*\* -Highly significant, \* -Significant, NS -Not significant

## APPENDIX IV

ANOVA Table of peak values for female subjects for right handle

ANOVA Table for peak maximum values for female subjects					
Source	Degrees of freedom	Mean square	F value	Probability (%)	Significance
Factor A	1	85.600	0.3839		NS
Factor B	3	255.746	1.1470	0.3451	NS
Factor S	1	1372.810	6.1570	0.0185	*
Factor A × B	3	21.913	0.0983		NS
Factor A × S	1	66.035	0.2962		NS
Factor B × S	3	539.132	2.4180	0.0844	NS
Factor A × B × S	3	65.275	0.2928		NS
ANOVA Table for peak minimum values for female subjects					
Source	Degrees of freedom	Mean square	F value	Probability (%)	Significance
Factor A	1	326.563	0.4291		NS
Factor B	3	234.938	0.3087		NS
Factor S	1	58.521	0.0769		NS
Factor A × B	3	1055.182	0.1382		NS
Factor A × S	1	1682.701	2.2108	0.1468	NS
Factor B × S	3	211.150	0.2774		NS
Factor A × B × S	3	97.991	0.1287		NS

\*\*-Highly significant, \* -Significant, NS -Not significant

## APPENDIX V

ANOVA Table of RMS values of HAV for female subjects at right handle

ANOVA Table for RMS maximum values for female subjects					
Source	Degrees of freedom	Mean square	F value	Probability (%)	Significance
Factor A	1	112.271	0.1242		NS
Factor B	3	387.756	0.4288		NS
Factor S	1	426.080	0.4712		NS
Factor A × B	3	148.164	0.1638		NS
Factor A × S	1	494.019	0.5463		NS
Factor B × S	3	945.479	1.0455	0.3858	NS
Factor A × B × S	3	143.415	0.1586		NS
ANOVA Table for RMS minimum values for female subjects					
Source	Degrees of freedom	Mean square	F value	Probability (%)	Significance
Factor A	1	326.563	0.4291		NS
Factor B	3	234.938	0.3087		NS
Factor S	1	58.521	0.0769		NS
Factor A × B	3	105.182	0.1382		NS
Factor A × S	1	1682.701	2.2108	0.1468	NS
Factor B × S	3	211.150	0.2774		NS
Factor A × B × S	3	97.991	0.1287		NS

\*\*-Highly significant, \* -Significant, NS -Not significant

## APPENDIX VI

ANOVA Table of Peak values of HAV for male subjects at left handle

ANOVA Table of peak maximum values for male subjects					
Source	Degrees of freedom	Mean square	F value	Probability (%)	Significance
Factor A	1	1443.214	11.3466	0.0020	**
Factor B	3	219.325	1.7243	0.1817	NS
Factor C	1	38.521	0.3029		NS
Factor A × B	3	84.564	0.6648		NS
Factor A × C	1	30.083	0.2365		NS
Factor B × C	3	195.278	1.5353	0.2243	NS
Factor A × B × C	3	36.714	0.2886		NS
ANOVA Table of peak minimum values for male subjects					
Source	Degrees of freedom	Mean square	F value	Probability (%)	Significance
Factor A	1	0.725	0.0018		NS
Factor B	3	1339.602	3.3004	0.0327	*
Factor C	1	2677.547	6.5968	0.0151	*
Factor A × B	3	226.472	0.5580		NS
Factor A × C	1	8.417	0.0207		NS
Factor B × C	3	49.242	0.1213		NS
Factor A × B × C	3	162.946	0.4015		NS

\*\*-Highly significant, \* -Significant, NS -Not significant

## APPENDIX VII

ANOVA Table of RMS values of HAV for male subjects at left handle

ANOVA Table of RMS maximum values for male subjects					
Source	Degrees of freedom	Mean square	F value	Probability (%)	Significance
Factor A	1	296.013	1.8814	0.1797	NS
Factor B	3	860.932	5.4718	0.0038	**
Factor C	1	340.267	2.1626	0.1512	NS
Factor A × B	3	61.579	0.3914		NS
Factor A × C	1	3.741	0.0238		NS
Factor B × C	3	380.608	2.4190	0.0843	NS
Factor A × B × C	3	247.231	1.5713	0.2155	NS
ANOVA Table of RMS minimum values for male subjects					
Source	Degrees of freedom	Mean square	F value	Probability (%)	Significance
Factor A	1	0.422	0.0016		NS
Factor B	3	497.355	1.8745	0.1538	NS
Factor C	1	229.250	0.8640		NS
Factor A × B	3	39.074	0.1473		NS
Factor A × C	1	0.017	0.0001		NS
Factor B × C	3	382.715	1.4424	0.2487	NS
Factor A × B × C	3	116.119	0.4376		NS

\*\*-Highly significant, \* -Significant, NS -Not significant

## APPENDIX VIII

ANOVA Table of Peak values of HAV for female subjects at left handle

ANOVA Table of peak maximum values for female subjects					
Source	Degrees of freedom	Mean square	F value	Probability (%)	Significance
Factor A	1	3439.161	8.2590	0.0071	**
Factor B	3	328.646	0.7892		NS
Factor C	1	1990.475	4.7800	0.0362	*
Factor A × B	3	8.387	0.0201		NS
Factor A × C	1	0.317	0.0008		NS
Factor B × C	3	1042.707	2.5040	0.0768	NS
Factor A × B × C	3	121.210	0.2911		NS
ANOVA Table of peak minimum values for female subjects					
Source	Degrees of freedom	Mean square	F value	Probability (%)	Significance
Factor A	1	967.505	1.1051	0.3010	NS
Factor B	3	1581.969	1.8070	0.1657	NS
Factor C	1	1284.435	1.4671	0.2347	NS
Factor A × B	3	33.244	0.0380		NS
Factor A × C	1	212.100	0.2423		NS
Factor B × C	3	1573.383	1.7972	0.1676	NS
Factor A × B × C	3	272.998	0.3118		NS

\*\*-Highly significant, \* -Significant, NS -Not significant

## APPENDIX IX

ANOVA Table of RMS values of HAV for female subjects at left handle

ANOVA Table of RMS maximum values for female subjects					
Source	Degrees of freedom	Mean square	F value	Probability (%)	Significance
Factor A	1	2842.841	5.0593	0.0315	*
Factor B	3	36.379	0.0647		NS
Factor C	1	63.941	0.1138		NS
Factor A × B	3	194.723	0.3465		NS
Factor A × C	1	14.963	0.0266		NS
Factor B × C	3	446.066	0.7938		NS
Factor A × B × C	3	64.228	0.1143		NS
ANOVA Table of RMS minimum values for female subjects					
Source	Degrees of freedom	Mean square	F value	Probability (%)	Significance
Factor A	1	5252.175	11.2318	0.0021	**
Factor B	3	214.882	0.4595		NS
Factor C	1	212.942	0.4554		NS
Factor A × B	3	216.334	0.4626		NS
Factor A × C	1	5.810	0.0124		NS
Factor B × C	3	1276.558	2.7299	0.0601	NS
Factor A × B × C	3	350.246	0.7490		NS

\*\*-Highly significant, \* -Significant, NS -Not significant

117

## APPENDIX X

a. ODR value for male subjects while operating brush cutter

ODR	2 stroke				4 stroke			
	I	II	III	Mean	I	II	III	Mean
N	2.0	2.0	2.0	2.0	2.0	1.5	2.0	1.8
B2	2.5	2.5	2.5	2.5	2.0	2.0	2.0	2.0
B3	4.0	4.0	4.5	4.1	4.0	3.5	4.0	3.8
C	4.0	4.5	4.5	4.3	4.0	4.0	4.5	4.1

b. ODR value for female subjects while operating brush cutter

ODR	2 stroke				4 stroke			
	I	II	III	Mean	I	II	III	Mean
N	4.0	3.5	3.0	3.5	2.5	2.5	3.0	2.7
B2	2.5	3.0	3.0	2.9	3.0	2.5	3.0	2.8
B3	5.0	4.5	4.0	4.5	5.0	3.0	4.0	4.0
C	5.0	5.0	5.0	5.0	5.0	4.5	5.0	4.8

c. ODR value for male subjects while operating brush cutter with attachment

ODR	2 stroke				4 stroke			
	I	II	III	Mean	I	II	III	Mean
N	3.0	3.0	3.0	3.00	3.0	2.0	2.0	2.33
B2	3.0	3.5	2.0	2.83	2.0	2.5	2.0	2.17
B3	4.0	5.0	3.5	4.17	4.0	3.5	3.0	3.50
C	5.0	4.5	4.5	4.67	5.0	4.0	4.5	4.50

d. ODR value for female subjects while operating brush cutter with attachment

ODR	2 stroke				4 stroke			
	I	II	III	Mean	I	II	III	Mean
N	3.0	3.0	3.5	3.17	2.5	2.5	3.0	2.67
B2	3.5	3.5	4.0	3.67	2.5	3.0	3.5	3.00
B3	4.0	4.0	4.5	4.17	4.0	4.5	4.5	4.33
C	5.0	5.0	5.5	5.17	4.5	5.0	5.0	4.83

## APPENDIX XI

a. OSR values for male subjects while operating Brush cutter

OSR	2 stroke				4 stroke			
	I	II	III	Mean	I	II	III	Mean
N	3.0	2.5	2.5	2.7	2.0	1.5	2.0	1.8
B2	2.5	3.0	3.3	2.93	2.1	2.6	2.5	2.4
B3	5.0	5.0	5.0	5.0	4.0	4.5	5.0	5.2
C	5.5	5.5	5.0	5.3	5.5	5.4	5.2	5.4

118

b. OSR values for female subjects while operating brush cutter

OSR	2 stroke				4 stroke			
	I	II	III	Mean	I	II	III	Mean
N	2.5	3.0	3.3	2.9	2.3	2.5	2.5	2.4
B2	3.0	3.0	3.5	3.2	3.0	3.0	3.5	3.2
B3	4.8	5.5	5.5	5.3	5.0	6.0	6.0	5.6
C	5.0	5.5	5.6	5.4	5.5	6.0	6.0	5.8

c. OSR values for male subjects while operating brush cutter with attachment

OSR	2 stroke				4 stroke			
	I	II	III	Mean	I	II	III	Mean
N	2.0	2.0	2.5	2.17	1.0	1.0	1.5	1.17
B2	2.0	2.5	2.5	2.33	2.0	2.0	2.0	2.00
B3	4.0	4.0	5.0	4.33	3.5	4.5	4.0	4.00
C	4.0	5.0	5.0	4.67	4.5	5.0	4.0	4.50

d. OSR values for female subjects while operating brush cutter with attachment

OSR	2 stroke				4 stroke			
	I	II	III	Mean	I	II	III	Mean
N	2.0	2.5	2.5	2.33	2.0	2.0	2.0	2.00
B2	3.0	2.5	3.0	2.83	2.0	2.5	2.5	2.33
B3	4.0	4.5	5.5	4.67	4.0	5.0	5.0	4.67
C	4.5	5.0	6.0	5.17	5.0	5.0	6.0	5.33

## APPENDIX XII

a. OER value for male subjects while operating brush cutters

OER	2 stroke				4 stroke			
	I	II	III	Mean	I	II	III	Mean
N	1.5	1.5	1.5	1.5	1.5	1.5	1.5	1.5
B2	1.5	2.0	2.0	1.8	1.0	1.5	1.5	1.4
B3	3.0	3.5	3.6	3.4	2.5	3.0	3.1	2.9
C	4.0	5.0	4.5	4.5	4.0	4.0	4.6	4.2

b. OER value for female subjects while operating brush cutters

OER	2 stroke				4 stroke			
	IV	V	VI	Mean	IV	V	VI	Mean
N	2.0	2.0	2.0	2.0	2.0	2.0	2.0	2.0
B2	2.0	2.5	2.6	2.4	2.0	2.0	2.5	2.1
B3	3.5	3.5	4.0	3.6	3.0	3.5	3.8	3.4
C	5.0	5.0	5.0	5.0	5.0	5.0	5.0	5.0

c. OER value for male subjects while operating brush cutters with attachment

OER	2 stroke				4 stroke			
	I	II	III	Mean	I	II	III	Mean
N	1.0	1.0	1.0	1.00	1.0	1.0	1.0	1.00
B2	1.0	1.5	1.5	1.33	1.0	1.0	1.0	1.00
B3	3.0	3.0	3.0	3.00	2.0	2.0	3.0	2.33
C	3.0	3.0	3.0	3.00	2.5	3.0	3.0	2.83



- d. OER value for female subjects while operating brush cutters with attachment

OER	2 stroke				4 stroke			
	IV	V	VI	Mean	IV	V	VI	Mean
N	1.0	1.0	1.0	1.00	1.0	1.0	1.0	1.00
B2	2.0	2.0	2.0	2.00	1.0	2.0	2.0	1.67
B3	3.0	3.0	4.0	3.33	3.0	3.0	3.0	3.00
C	4.0	4.0	4.0	4.00	4.0	4.0	4.0	4.00

### APPENDIX XIII

- a. BPDS values for male subjects while operating brush cutters with attachment

	Subject	1	2	3	4	5	6	BPDS
2 stroke	I	2	2,4,1	13,15	7	9	12,14,3,11	39
		6	15	8	4	2	4	
	II		2,4,1	20,13,15	7	9	12,14,11	39
			15	16	3	2	3	
	III	2,4	21,13,15	1	7,9		14,11	34
		12	15	4	6	-	2	
Mean								37.33
4 stroke	I		2,3	13,15	21	7,9,18	4,5,19,12,14	32
			10	8	3	6	5	
	II	2	4,3	13,15	21	7,9,18	4,5,12,14	31
		6	10	8	3	6	4	
	III	2,3		13,15	21	7,9,18	4,5,12,14,19	34
		12		8	3	6	5	
Mean								32.33

- b. BPDS values for female subjects while operating brush cutters with attachment

	Subject	1	2	3	4	5	6	BPDS
2 stroke	IV	2,4,21		19,7,9,13,15	1,18	3	12,14	43
		18		15	6	2	2	
	V	2,4	21,13,15	19	7,9	1,18	12,14	43
		12	15	4	6	4	2	
	VI		21,13,15,2,4	19,1,9	7		12,14,11,18	44
			25	12	3	-	4	
Mean								43.33
4 stroke	IV	2,3	21,18,19		13,15	7,9	4,5,12,14	41
		12	15		6	4	4	
	V	2,3	21	18,19	13,15	7,9	4,5,12,14	39
		12	5	8	6	4	4	
	VI	2,3	21	13,15	7,9	18,19	4,5,12,14	35
		12	5	8	6		4	
Mean								38.33

## c. BPDS values for male subjects while operating Brush cutters

	Subject	1	2	3	4	5	6	BPDS
2 stroke	I	2,4,1	21,13,15	7	9		12,14,3,11	44
		18	15	4	3	-	4	
	II	2,4	20,13,15	7,1	9	18	12,14,11	43
		12	15	8	3	2	3	
	III	2,4	21,13,15	1	7,9		12,14,11	40
		12	15	4	6	-	3	
Mean								42.33
4 stroke	I	2,3	13,15	21	7	9,18	4,5,19,12,14	38
		12	10	4	3	4	5	
	II	2,3	13,15	21	7,9	18	4,5,12,14	38
		12	10	4	6	2	4	
	III	2,3	13,15	21	7,9,18	19	4,5,12,14	40
		12	10	4	9	1	4	
Mean								38.67

## d. BPDS values for female subjects while operating Brush cutters

	Subject	1	2	3	4	5	6	BPDS
2 stroke	IV	2,4,21	13,15	19,7,9	1,18	3	12,14	50
		18	10	12	6	2	2	
	V	2,4	21,13,15	19,7,9	1,18		12,14	47
		12	15	12	6	-	2	
	VI	2,4	21,13,15	19,1	7,9		12,14,11	44
		12	15	8	6	-	3	
Mean								47.33
4 stroke	IV	2,3	21,18,19	13,15	7,9		4,5,12,14	45
		12	15	8	6	-	4	
	V	2,3	21	18,19,1 3,15	7,9		4,5,12,14	43
		12	5	16	6	-	4	
	VI	2,3	21	13,15	7,9,18, 19,20		4,5,12,14	44
		12	5	8	15	-	4	
Mean								44.00

(21)

**ERGONOMIC INVESTIGATIONS ON HAND ARM  
VIBRATION OF BRUSH CUTTER FOR THE  
DEVELOPMENT OF A VIBRATION REDUCING AID**

**By**  
**ASWATHI K.**  
**(2014-18-112)**

**ABSTRACT OF THE THESIS**

Submitted in partial fulfilment  
Of the requirement for the award of degree of  
**MASTER OF TECHNOLOGY**  
**IN AGRICULTURAL ENGINEERING**  
(Farm Power and Machinery)  
Faculty of Agricultural Engineering and Technology  
Kerala Agricultural University



*Department of Farm Power, Machinery and Energy*  
**KELAPPAJI COLLEGE OF AGRICULTURAL ENGINEERING AND TECHNOLOGY**  
**TAVANUR - 679 573, MALAPPURAM**  
**KERALA, INDIA**  
**2016**

## ABSTRACT

Brush cutters are widely used in Kerala for weeding and clearing fields. While operating brush cutters, certain amount of vibration is transmitted to human body. Extended exposure to mechanical vibration can induce degeneration of the vascular and sensio-neural systems in the hand called hand-arm vibration syndrome (HAVS). The hand-arm vibration syndrome (HAVS) is a complex condition associated with vibration exposure and the use of hand-held vibrating machines.

The vibration exposure of worker can be decreased by proper selection and maintenance of tool. To study the ergonomic aspects and hand transmitted vibrations of brush cutters, six subjects (3 male & 3 female) were selected who are having experience in operation of brush cutter. A suitable vibration reducing aid for brush cutters is designed and fabricated keeping the view that it should be capable of transmitting at least a part of the vibration produced at cutter head to the ground. It should be easily attached or detached from the brush cutters shaft. The material used for the vibration reduction aid should be light in weight and sturdy, so that it could be raised along with the cutter head by the operator. According to the conceptual design, a vibration reduction aid is developed and field tested. It consists of parts viz. curved arms, fixture to arms, quick fixing locks, ground rollers, rollers fixture and rubber grip.

The brush cutter and vibration reducing aid is evaluated in the field with different cutter heads viz. nylon rope, 2 blade, 3 blade and circular blade. The experiment is repeated for 2-stroke and 4-stroke models of brush cutters operated by male and female subjects. The energy expenditure for brush cutter operation is calculated for two models of brush cutter for all subjects and compared. A statistical analysis is conducted using MSTAT software and found that the developed vibration reducing aid, blade and type of internal combustion engine have significant effect on vibration excitation in both right and left handles of brush cutters selected. The proposed method of evaluating occupational risk related to mechanical vibration exposure while working with brush cutter makes it possible to account the effect of attachment, cutter head and type of internal combustion

engine. Subjective ratings like ODR, OER, OSR and BPDS also indicated significant effect of reducing vibration due to the vibration reducing aid.

